

**INNOVATING
SAFETY**

since 1978

EXTREME LINE

Cilindri ad azoto

Gas Springs



Gasdruckfedern

Ressorts à Gaz

Cilindros de Gas

Cilindros de Nitrogênio



4	PROTECTION - SAFETY
14	OPERATING INSTRUCTIONS - USER INFORMATION
26	HOW TO READ THE CATALOG - SELECTION TAB
30	NCS
40	NML
48	NMS
54	NC
58	NMX
66	NMC
70	NT
75	 Installation guideline / Flange mounts
100	SW Secondary rod wiper
103	 Easy manifold
118	 Accessories
134	EYE, NITRO STRIP, NITROGEN PUNCHING UNIT



SW

Raschiatore secondario
Secondary rod wiper
Zweitabstreifer
Racleur de tige secondaire
Rascador de vástago secundario
Anillo raspador secundário

More info:  p. 100



Benefits

IT

- Eccellente protezione da contaminanti liquidi e solidi.
- Poliuretano ad alte prestazioni per massima resistenza chimica ai lubrificanti.
- Aumentata durata di vita di guide e tenute dinamiche.
- Minima perdita di corsa nominale.
- Facile inserimento.
- Nessuna limitazione al libero posizionamento del cilindro.

EN

- Excellent protection from liquid and solid contaminants.
- Maximum chemical resistance to lubricants thanks to high-performance polyurethane.
- Longer lifetime for guiding elements and dynamic seals.
- Minimal loss of nominal stroke.
- Easy to insert.
- No restrictions when positioning the gas spring.

DE

- Ausgezeichneter Schutz gegen feste und flüssige Verunreinigungen.
- Maximale chemische Beständigkeit gegen Schmierstoffe durch das Hochleistungs-Polyurethan.
- Längere Lebensdauer für Führungselemente und dynamische Dichtungen.
- Minimaler Verlust des Nennhubes.
- Einfaches Einsetzen.
- Keine Einschränkungen für die Positionierung der Gasdruckfeder.

FR

- Excellente protection contre contaminants liquides et solides.
- Résistance chimique maximale aux lubrifiants grâce au polyuréthane de haute performance.
- Plus longue durée de vie pour les éléments de guidage et les joints dynamiques.
- Perte minimale de la course nominale.
- Facile à insérer.
- Pas de limitations dans le positionnement du ressort-gaz.

ES

- Protección óptima contra los contaminantes líquidos y sólidos.
- Máxima resistencia química a lubricantes gracias al poliuretano de alto rendimiento.
- Mayor vida útil para elementos de guía y juntas dinámicas.
- Pérdida mínima de carrera nominal.
- Fácil de colocar.
- Ninguna limitación para el posicionamiento del cilindro.

PT

- Excelente protecção contra contaminantes líquidos e sólidos.
- Máxima resistência química aos lubrificantes graças ao poliuretano de alto desempenho.
- Aumento do tempo de vida útil dos elementos de guia e vedações.
- Perda mínima de curso nominal.
- Fácil de inserir.
- Não há restrições ao posicionar o cilindro.

**VDI
3003**

OPAS

Sicurezza Attiva Oltre Pressione
Over Pressure Active Safety
Aktive Überdruck-Sicherheitsvorrichtung
Sécurité Active Surpression
Seguridad Activa por Sobrepresión
Segurança Sobre Pressão

**VDI
3003**

OSAS

Sicurezza Attiva Oltre Corsa
Over Stroke Active Safety
Aktive Überhubsicherung
Sécurité Active pour Surcourse
Seguridad Activa de Fin de Carrera
Segurança para Sobre Curso

**VDI
3003**

USAS

Sicurezza Attiva Ritorno Incontrollato
Uncontrolled Speed Active Safety
Aktiver Schutz bei unkontrolliertem Rückhub
Sécurité Active pour Retour Incontrôlé
Seguridad Activa de Retorno Incontrolado
Segurança para Retorno Descontrolado

How it works

IT

- Scarica in modo controllato e completo la pressione del cilindro ad azoto quando viene superato il valore massimo consentito.

EN

- Exhausts the pressure in a controlled and complete manner when it exceeds the maximum allowed value.

DE

- kontrollierte und vollständige Entladung des Innendrucks des Zylinders bei Überschreiten des maximal zulässigen Werts.

FR

- Décharge la pression du ressort en mode contrôlé et complet lorsque la valeur maximale admissible est dépassée.

ES

- Descarga la presión de manera controlada y completa cuando se supera el valor máximo permitido.

PT

- Esvazia a pressão do cilindro de forma controlada e completa quando ele excede o valor máximo permitido.

IT

- Scarica in modo controllato e completo la pressione interna del cilindro ad azoto quando ha subito un'oltre corsa.

EN

- Exhausts pressure in a controlled and complete manner, when the gas spring has been overstroked.

DE

- Ermöglicht das kontrollierte und komplette Entladen des Innendrucks der Gasdruckfeder bei Überhub.

FR

- Décharge la pression du ressort en mode contrôlé et complet dans le cas d'une surcourse.

ES

- Descarga la presión de manera controlada y completa en caso de que el cilindro sobrepase su carrera máxima.

PT

- Esvazia a pressão do cilindro de forma controlada e completa quando ele sofre sobre-curso.

IT

- Scarica in modo controllato e completo la pressione del cilindro ad azoto quando soggetto a ritorni incontrollati.

EN

- Exhausts pressure in a controlled and complete manner when the gas spring has been stressed by uncontrolled returns.

DE

- ermöglicht das kontrollierte und komplette Entladen des Innendrucks der Gasdruckfeder bei unkontrolliertem Rückhub.

FR

- Décharge la pression du ressort en mode contrôlé et complet dans de cas des retours non contrôlés.

ES

- Descarga la presión de manera controlada y completa en caso de que el cilindro sufra un retorno incontrolado.

PT

- Quando o cilindro sofrer retornos descontrolados, o mesmo se esvazia de uma maneira controlada e completa.

Benefits

IT

- Riduce il rischio di danni e pericoli dovuti alla proiezione di parti in pressione.
- Si attiva automaticamente senza intervento dell'operatore.
- Non aumenta il prezzo del cilindro.

EN

- Reduces the risk of tool damage or injury due to ejection of parts under pressure.
- Self activates automatically regardless of users' intervention.
- Does not increase the price of gas springs.

DE

- Reduziert das Risiko von Schäden und Gefahren durch wegschleudernde, unter Druck stehende Teile.
- Aktiviert sich automatisch ohne Zutun des Nutzers.
- Erhöht die Kosten der Gasdruckfeder nicht.

FR

- Réduit le risque d'endommagement de l'outil ou le risque de blessure en cas d'éjection de pièces ou composants sous pression.
- S'auto-active sans intervention de l'opérateur.
- N'augmente pas le prix du ressort.

ES

- Reduce el riesgo de daños y peligros consecuencia de la proyección de partes bajo presión.
- Se activa automáticamente sin intervención del usuario.
- No aumenta el precio del cilindro.

PT

- Reduz o risco de danos para a ferramenta e ferimentos para o operador por estilhaços.
- Ativa-se automaticamente independentemente de intervenção dos usuários.
- Não aumenta o preço dos cilindros.

SAFETY



Over
Pressure
Active
Safety

VDI
3003



Standard on: NML - NMX - NC

IT OPAS è la combinazione di un tappo di rottura con una fresatura di scarico sulla base di appoggio del cilindro ad azoto.

EN OPAS is the combination of a rupture plug with an exhaust milling on the contact surface of the gas spring.

DE OPAS ist die Kombination aus einem kalibrierten Sollbruchstopfen mit einer Auslaufrille an der unteren Auflagefläche der Gasdruckfeder.

FR OPAS est la combinaison d'un bouchon de sécurité avec un fraisage de déchargement sur la surface inférieure du ressort gaz.

ES OPAS es la combinación de un tapón de rotura (o de un septo de rotura) con un fresado de descarga posicionados en la base de apoyo del cilindro.

PT OPAS é a combinação de um plugue de ruptura com um canal usinado na parte inferior do cilindro.

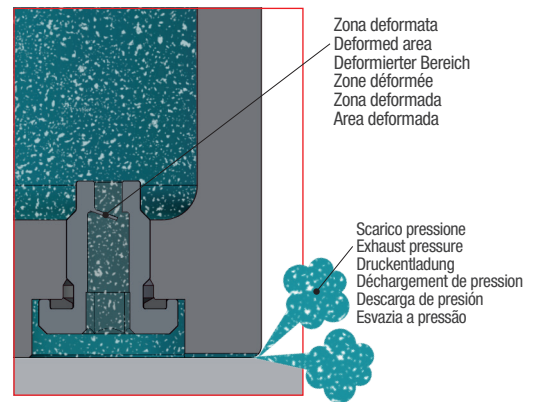
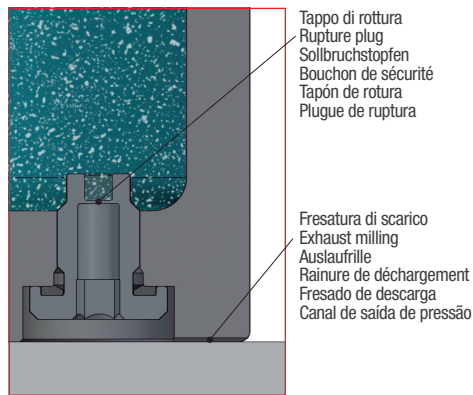

Standard on: NT - NCS

IT OPAS è la combinazione di un setto di rottura calibrato con una fresatura di scarico sulla base di appoggio del cilindro ad azoto.

EN OPAS is the combination of a rupture septum with an exhaust milling on the contact base of the gas spring.

DE OPAS ist die Kombination aus einem kalibrierten Sollbruchstelle mit einer Auslaufrille an dem unteren Stützpunkt der Gasdruckfeder.

FR OPAS est la combinaison d'un septum de rupture calibré avec un fraisage de déchargement sur la base d'appui du ressort gaz.

ES OPAS es la combinación de un septo de rotura con un fresado de descarga posicionados en la base de apoyo del cilindro.

PT OPAS é a combinação de um septo de ruptura com um canal usinado na base de apoio do cilindro.

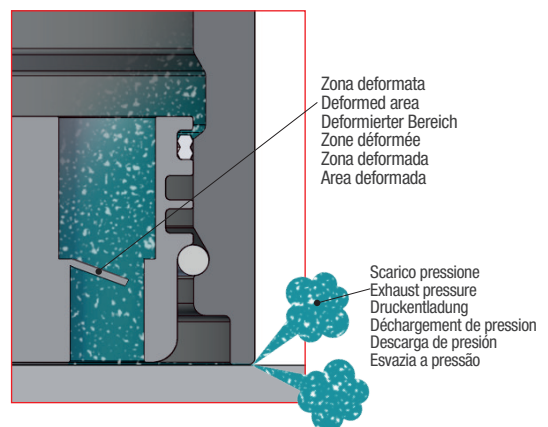
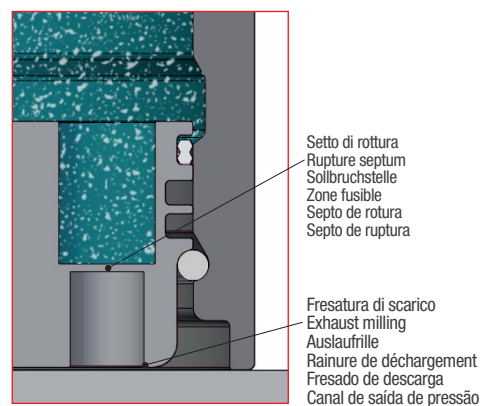

**Standard on: NMX19 - NMX25 - NCS19
NML25 - NMS19 - NMS25 - NMC 19**

IT OPAS è la combinazione di un setto di rottura calibrato con una fresatura di scarico sulla base di appoggio del cilindro ad azoto.

EN OPAS is the combination of a rupture septum with an exhaust milling on the contact base of the gas spring.

DE OPAS ist die Kombination aus einem kalibrierten Sollbruchstelle mit einer Auslaufrille an dem unteren Stützpunkt der Gasdruckfeder.

FR OPAS est la combinaison d'un septum de rupture calibré avec un fraisage de déchargement sur la base d'appui du ressort gaz.

ES OPAS es la combinación de un setpo de rotura con un fresado de descarga posicionados en la base de apoyo del cilindro.

PT OPAS é a combinação de um setpo de ruptura com um canal usinado na base de apoio do cilindro.

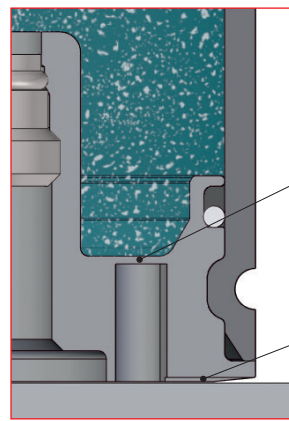

Setto di rottura
Rupture septum
Sollbruchstelle
Zone fusible
Septo de rotura
Septo de ruptura

Fresatura di scarico
Exhaust milling
Auslaufrille
Rainure de déchargement
Fresado de descarga
Canal de saída de pressão

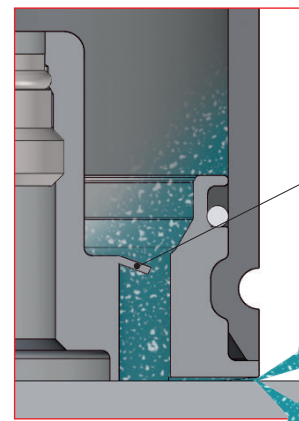

Zona deformata
Deformed area
Deformierter Bereich
Zone déformée
Zona deformada
Area deformada

Scarico pressione
Exhaust pressure
Druckentladung
Déchargement de pression
Descarga de presión
Esvazia a pressão

In caso di attivazione di una sicurezza, verificare e scaricare eventuali residui di pressione, eliminare le cause del danno e sostituire sempre il cilindro ad azoto danneggiato.

If the safety features are activated, verify and exhaust the possible pressure leftovers, remove the causes of the damage and replace always the damaged gas spring.

Wenn die Sicherungen aktiviert werden, prüfen und entladen Sie eventuellen Restdruck, beseitigen Sie die Ursachen des Schadens und ersetzen Sie immer die beschädigte Gasdruckfeder.

Quand les sécurités sont activées, vérifier et décharger les éventuels résidus de pression, éliminer les causes de l'endommagement et toujours remplacer les ressorts gaz endommagés.

Si se activan los dispositivos de seguridad, verificar y descargar toda la presión residual, eliminar las causas de los daños y reemplazar siempre el cilindro dañado.

Se os dispositivos de segurança são ativados, verificar e descarregar qualquer pressão residual, eliminar as causas dos danos e substituir sempre o cilindro danificado.



SAFETY



Over
Stroke
Active
Safety

VDI
3003

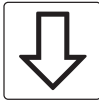

Standard on: NML - NMX - NC

IT OSAS è un dispositivo di sicurezza costituito da un elemento posizionato alla base del corpo caratterizzato da una zona a deformazione controllata.

EN OSAS is a safety feature placed at the base of the body. It is made of a component with a controlled deformation area.

DE OSAS ist eine Sicherheitsvorrichtung, die aus einem am Boden angebrachten Element mit kontrolliert deformierbarem Bereich besteht.

FR OSAS est un dispositif de sécurité placé à la base du corps. Il est constitué d'un composant avec une zone de déformation contrôlée.

ES OSAS es un dispositivo de seguridad constituido por un elemento posicionado en la base del cuerpo y caracterizado por una zona con deformación controlada.

PT OSAS é um dispositivo de segurança localizado na base do corpo do cilindro. É um componente com uma área de deformação controlada.

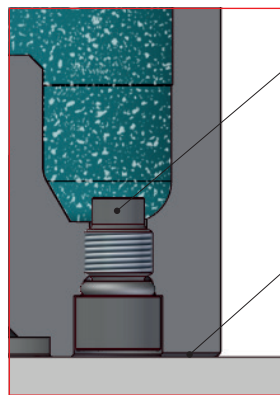

Tappo di rottura
Rupture plug
Solbruchstopfen
Bouchon de sécurité
Tapón de rotura
Plugue de ruptura

Fresatura di scarico
Exhaust milling
Auslaufrille
Rainure de déchargement
Fresado de descarga
Canal de saída de pressão

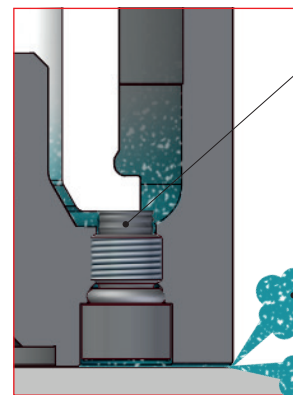

Zona deformata
Deformed area
Deformierter Bereich
Zone déformée
Zona deformada
Area deformada

Scarico pressione
Exhaust pressure
Druckentladung
Déchargement de pression
Descarga de presión
Esvazia a pressão

Standard on: NT - NCS - NMC25

IT OSAS è la combinazione di una zona deformabile del corpo e delle gole di scarico presenti sulla superficie interna del corpo.

EN OSAS is the combination of a deformable body skirt and of the exhaust grooves on the internal body surface.

DE OSAS ist die Kombination einer deformierbaren Zone des Körpers und der Auslaufrillen an der Innenoberfläche des Körpers.

FR OSAS est la combinaison d'une zone déformable du corps et des rainures de déchargement sur la surface interne du corps.

ES OSAS es la combinación de una zona deformable del cuerpo y de las ranuras de descarga en la superficie interna del cuerpo.

PT OSAS é a combinação de uma área do corpo deformável e das ranhuras de saída de pressão na superfície interna do corpo.

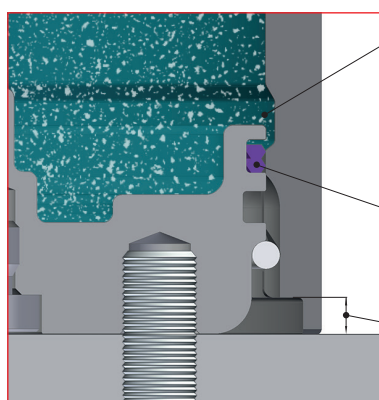
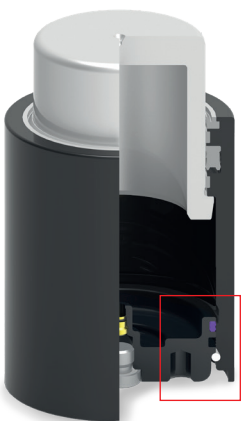

Gola di scarico
Exhaust groove
Auslaufrille
Rainure de déchargement
Ranura de descarga
Ranhura de saída de pressão

Guarnizione - Seal
Dichtung - Joint
Junta - Vedação

Zona deformabile
Deformed area
Deformierbarer Bereich
Zone déformable
Zona deformable
Area Deformável

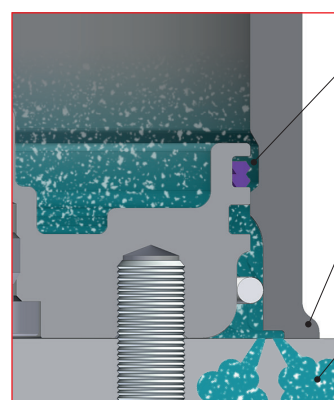

Guarnizione su gole di scarico
Seal on exhaust grooves
Dichtung an den Auslaufrillen
Joint sur les rainures
Junta en las ranuras
Anel de vedação dentro das ranhuras

Deformazione
Deformed area
Verformung
Déformation
Deformación
Area Deformada

Scarico pressione
Exhaust pressure
Druckentladung
Déchargement de pression
Descarga de presión
Esvazia a pressão

Standard on: NML25 - NMX19 - NMX25

IT OSAS è un dispositivo di sicurezza costituito da un elemento posizionato sul fondo caratterizzato da una zona a deformazione controllata.

EN OSAS is a safety feature placed at bottom base. It is made of a component with a controlled deformation area.

DE OSAS ist eine Sicherheitsvorrichtung, die aus einem an der Bodenplatte angebrachten Element mit kontrolliert deformierbarem Bereich besteht.

FR OSAS est un dispositif de sécurité constitué d'un composant placé à la base du corps, avec une zone de déformation contrôlée.

ES OSAS es un dispositivo de seguridad constituido por un elemento posicionado en la base del cuerpo y caracterizado por una zona con deformación controlada.

PT OSAS é um dispositivo de segurança localizado na base do corpo do cilindro. É um componente com uma área de deformação controlada.

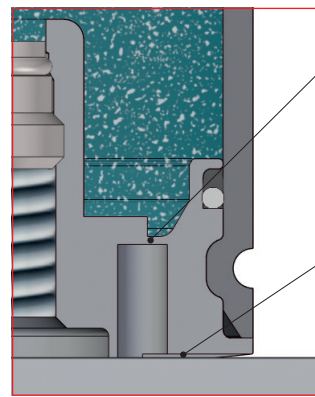

Tappo di rottura
Rupture plug
Sollbruchstopfen
Bouchon de sécurité
Tapón de rotura
Plugue de ruptura

Fresatura di scarico
Exhaust milling
Auslaufrille
Rainure de déchargement
Fresado de descarga
Canal de saída de pressão

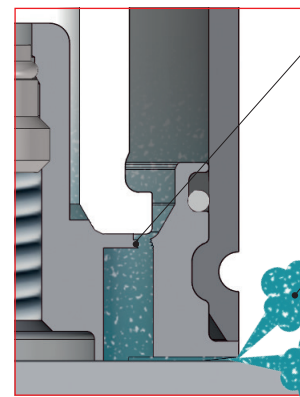

Zona deformata
Deformed area
Deformierter Bereich
Zone déformée
Zona deformada
Area deformada

Scarico pressione
Exhaust pressure
Druckentladung
Déchargement de pression
Descarga de presión
Esvazia a pressão

In caso di attivazione di una sicurezza, verificare e scaricare eventuali residui di pressione, eliminare le cause del danno e sostituire sempre il cilindro ad azoto danneggiato.

In case of activation of a safety device, verify and exhaust the possible pressure leftovers, remove the causes of the damage and always replace the damaged gas spring.

Bei der Aktivierung der Sicherheitsvorrichtung, prüfen und entladen Sie eventuellen Restdruck, beseitigen Sie die Ursachen des Schadens und ersetzen Sie immer die beschädigte Gasdruckfeder.

En cas d'activation d'un dispositif de sécurité, vérifier et décharger les éventuels résidus de pression, éliminer les causes de l'endommagement et toujours remplacer les ressorts gaz endommagés.

En caso de activación de un dispositivo de seguridad, verificar y descargar toda la presión residual, eliminar las causas de los daños y reemplazar siempre el cilindro dañado.

No caso da ativação de um dispositivo de segurança, verificar e descarregar qualquer pressão residual, eliminar as causas dos danos e substituir sempre o cilindro danificado.



SAFETY



Uncontrolled
Speed
Active
Safety

VDI
3003

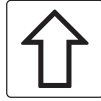

Standard on: NML - NMX - NC

IT USAS è la combinazione di una zona deformabile della boccola e delle gole di scarico presenti sulla superficie interna del corpo.

EN USAS is the combination of a deformable area of the bushing and the exhaust grooves on the internal body surface.

DE USAS besteht aus der Kombination eines verformbaren Bereichs der Buchse und den Auslaufrillen an der Innenoberfläche des Körpers.

FR USAS est la combinaison d'une zone déformable de la douille et des rainures de déchargement sur la surface interne du corps.

ES USAS es la combinación de una zona deformable del casquillo y de las ranuras de descarga en la superficie interna del cuerpo.

PT USAS é a combinação de uma parte deformável da bucha e as ranhuras de saída de pressão na superfície interna do corpo.

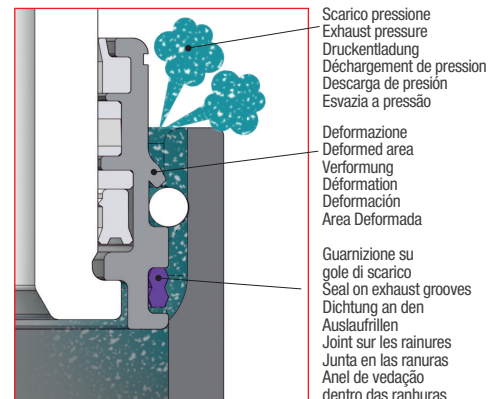
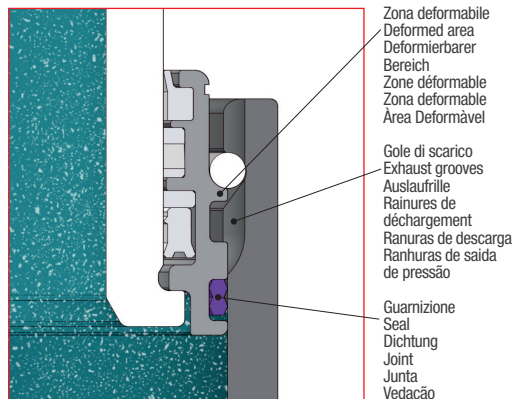

Standard on: NT - NCS - NMC25

IT USAS è la combinazione di una zona deformabile del fondello e delle gole di scarico presenti sulla superficie interna del corpo.

EN USAS is the combination of a deformable area of the bottom base and the exhaust grooves on the internal body surface.

DE USAS ist die Kombination eines deformierbaren Bereichs am Boden und den Auslaufrillen an der Innenoberfläche des Körpers.

FR USAS est la combinaison d'une zone déformable de la plaque inférieure et des rainures de déchargement sur la surface interne du corps.

ES USAS es la combinación de una zona deformable de la placa inferior y de las ranuras de descarga en la superficie interna del cuerpo.

PT USAS é a combinação de uma area deformável da placa base e das ranhuras de saída de pressão na superfície interna do corpo.

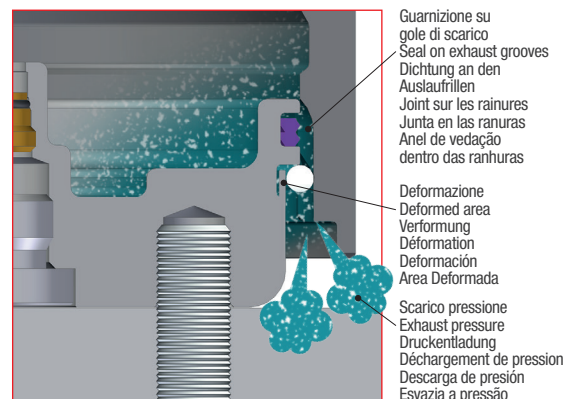
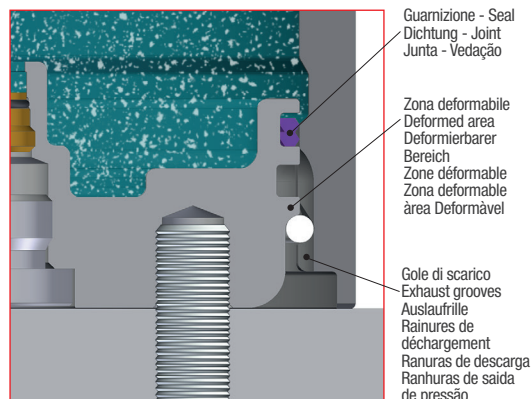
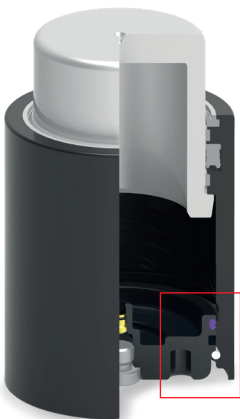

Standard on: NML25 - NMX19 - NMX25

IT USAS è la combinazione di una zona deformabile della boccola e di una gola di scarico presente sulla superficie dello stelo.

EN USAS is the combination of a deformable area of the bushing and the exhaust grooves positioned on the internal rod surface.

DE USAS besteht aus der Kombination eines verformbaren Bereichs der Buchse und den Auslaufrillen an der Innenoberfläche der Kolbenstange.

FR USAS est la combinaison d'une zone déformable de la douille et des rainures de déchargement sur la surface interne de la tige.

ES USAS es la combinación de una zona deformable del casquillo y de las ranuras de descarga en la superficie interna del vástago.

PT USAS é a combinação de uma parte deformável da bucha e as ranhuras de saída de pressão na superfície interna dela haste.

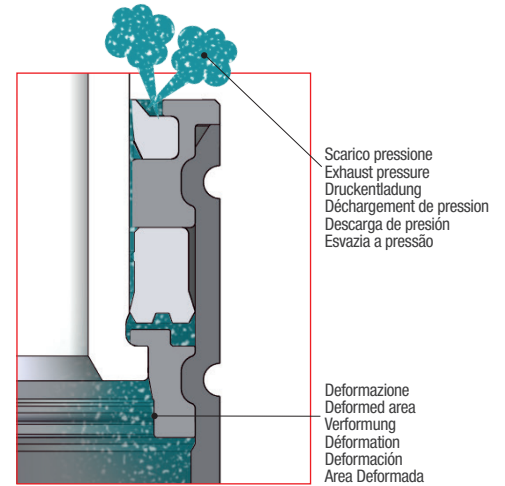
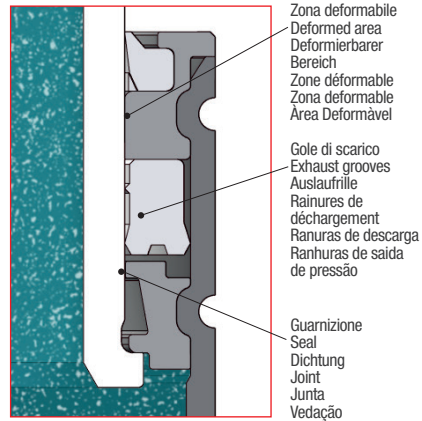
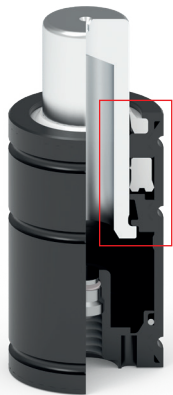

In caso di attivazione di una sicurezza, verificare e scaricare eventuali residui di pressione, eliminare le cause del danno e sostituire sempre il cilindro ad azoto danneggiato.

If the safety features are activated, verify and exhaust the possible pressure leftovers, remove the causes of the damage and replace always the damaged gas spring.

Wenn die Sicherungen aktiviert werden, prüfen und entladen Sie eventuellen Restdruck, beseitigen Sie die Ursachen des Schadens und ersetzen Sie immer die beschädigte Gasdruckfeder.

Quand les sécurités sont activées, vérifier et décharger les éventuels résidus de pression, éliminer les causes de l'endommagement et toujours remplacer les ressorts gaz endommagés.

Si se activan los dispositivos de seguridad, verificar y descargar toda la presión residual, eliminar las causas de los daños y reemplazar siempre el cilindro dañado.

Se os dispositivos de segurança são ativados, verificar e descarregar qualquer pressão residual, eliminar as causas dos danos e substituir sempre o cilindro danificado.



1381



PED 2014/68/EU

IT

- La progettazione e la produzione dei cilindri ad azoto Special Springs sono realizzate nel pieno rispetto delle normative vigenti per i recipienti in pressione come stabilito dalla direttiva PED 2014/68/EU e EN 13445:2015.

EN

- The design and manufacturing of Special Springs gas springs are in full compliance with the European regulations for high pressure vessels, in accordance with directive PED 2014/68/EU and EN 13445:2015.

DE

- Die Konstruktion und Herstellung der Special Springs Gasdruckfedern erfolgt in Übereinstimmung mit den geltenden Normen für Druckbehälter, wie in der PED Richtlinie 2014/68/EU und EN 13445:2015 festgelegt.

FR

- La conception et la fabrication des ressorts à gaz Special Springs sont en totale conformité avec les législations Européennes en matière de composants caractérisés haute pression et notamment avec la directive PED 2014/68/EU et EN 13445:2015.

ES

- La proyectación y producción de los cilindros de nitrógeno Special Springs se realizan con pleno respeto de las normativas vigentes para elementos de presión como establece la directiva PED 2014/68/EU y EN 13445:2015).

PT

- O projeto e fabricação de cilindros de Nitrogênio Special Springs estão em total conformidade com as regras Europeias para Cilindros de alta pressão, em conformidade com a directiva PED 2014/68/EU e EN 13445:2015.

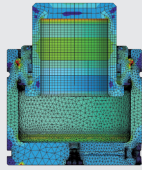

FEM - CAE

IT

- Tutti i prodotti Special Springs sono sviluppati e validati con l'utilizzo dei più avanzati sistemi di analisi FEM (finite element method) e CAE (computer aided engineering).

EN

- All Special Springs products are developed and validated via the use of the most advanced FEM (finite element method) and CAE (computer aided engineering) analysis systems.

DE

- Alle Produkte von Special Springs werden durch die Verwendung der fortschrittlichsten Analysensysteme FEM (finite element method) und CAE (computer aided engineering) entwickelt und validiert.

FR

- Tous les produits Special Springs sont développés et certifiés selon les méthodes FEM (finite element method) et CAE (Computer aided engineering).

ES

- Todos los productos Special Springs son desarrollados y validados con la utilización de los más avanzados sistemas de análisis FEM (finite element method) y CAE (computer aided engineering).

PT

- Todos os produtos Special Springs são desenvolvidos e validados através da utilização das Técnicas mais avançadas FEM (método de elementos finitos) e sistemas de análise do CAE (Engenharia assistida por computador).

> 2.000.000

STRUCTURE OF THE GAS SPRING

IT

- Tutti i componenti strutturali dei cilindri ad azoto Special Springs sono progettati e costruiti per sopportare minimo 2.000.000 di cicli completi alla massima pressione, temperatura e per ogni tipo di fissaggio.

EN

- All structural components of Special Springs gas springs are designed and built to withstand a minimum of 2,000,000 complete cycles at maximum pressure, temperature and for all types of fixings.

DE

- Alle Strukturkomponenten der Special Springs Gasdruckfedern sind so konzipiert und hergestellt, um mindestens 2.000.000 komplette Zyklen bei maximalem Druck und Temperatur und für jede Befestigungsart zu erreichen.

FR

- Tous les composants structuraux des ressorts gaz Special Springs sont conçus et construits pour supporter un minimum de 2 million des cycles complètes à la pression et température maximale pour chaque type de fixation.

ES

- Todos los componentes estructurales de los cilindros de gas Special Springs están diseñados y fabricados para soportar un mínimo de 2.000.000 de golpes completos a la máxima presión, temperatura y para cualquier tipo de fijación.

PT

- Todos os componentes estruturais dos cilindros Special Springs, são projetados e construídos para suportar no mínimo 2.000.000 ciclos com máxima pressão, temperatura e para todos os tipos de dispositivos de fixação.

Benefits

IT

- Maggiore garanzia di prodotti e componenti sicuri per il cliente.

EN

- Greater assurance of safe products and components for customers.

DE

- verbesserte Sicherheit für den Kunden durch sichere Produkte und Komponenten.

FR

- Plus grande assurance de produits et composants sûrs pour les clients.

ES

- Mayor garantía de productos y componentes seguros para los clientes.

PT

- Maior garantia de produtos e componentes seguros para os clientes.



KNOWLEDGE

IT

- La conoscenza è un elemento fondamentale per azioni quotidiane di successo, più conosciamo meglio facciamo. Questo concetto è da sempre presente nella filosofia del lavoro di Special Springs. Da molti anni Special Springs è impegnata per aumentare la conoscenza dei prodotti e delle loro caratteristiche unitamente alle migliori tecniche di utilizzo attraverso formazioni teoriche e pratiche.

EN

- Knowledge is an essential element for successful daily actions; the more we know, the better we perform. This concept has always been one of Special Springs' core values. For many years the company has committed to increase knowledge of products along with their characteristics and their best utilisations techniques, through theoretical and practical training.

DE

Fachkenntnis ist ein grundlegendes Element für tägliche, erfolgreiche Tätigkeiteng, je mehr wir wissen, desto besser können wir handeln. Dieses Konzept ist schon immer die Arbeitsphilosophie von Special Springs. Seit vielen Jahren ist Special Springs bestrebt, die Fachkenntnisse rund um die Produkte und ihre technischen Eigenschaften zusammen mit den neuesten Anwendungstechniken zu perfektionieren und durch theoretische und praktische Schulungen zu vertiefen.

FR

- La connaissance est un élément fondamental pour les actions quotidiennes de succès, mieux on connaît, mieux on fait. Ce concept a été toujours présent dans la philosophie de travail de Special Springs. Depuis plusieurs années Special Springs s'est engagé à augmenter la connaissance des produits et de ses caractéristiques mais aussi aux meilleures techniques d'usage à travers formations théoriques et pratiques.

ES

- El conocimiento es un elemento fundamental para acciones cotidianas que lleven al éxito, cuanto más se conoce mejor se hace. Este concepto ha estado siempre en la filosofía de trabajo de Special Springs. Special Springs se dedica desde hace muchos años a aumentar su conocimiento sobre los productos y sus características, así como a mejorar las técnicas de uso a través de formaciones teóricas y prácticas.

PT

- O conhecimento é um elemento essencial para o sucesso das ações diárias; Quanto mais soubermos, melhor nós executamos. Este conceito sempre foi um dos valores da Special Springs. Por muitos anos a empresa se comprometeu a aumentar os conhecimentos dos produtos juntamente com suas características e suas melhores técnicas de utilizações através de formação teórica e prática.



TECHNICAL SUPPORT

IT

- Special Springs, da sempre impegnata per migliorare il supporto tecnico agli utilizzatori, fornisce con ogni cilindro o suo componente un completo foglio di istruzioni multilingua.

EN

- Special Springs has always been committed to provide technical support for users; we provide a thorough multilingual instruction sheet with each gas spring or component.

DE

- Special Springs ist schon immer bestrebt, den technischen Support der Anwender zu verbessern, für jede Gasdruckfeder und deren Komponenten ist eine mehrsprachige Betriebsanleitung verfügbar.

FR

- Special Springs s'est engagée depuis longtemps pour améliorer le support technique aux utilisateurs, elle fournit avec chaque ressort ou composant un papier d'instruction multilingue complet.

ES

- Es prioridad desde siempre para Special Springs la mejora del soporte técnico al usuario, para lo que entrega un manual completo en varios idiomas con cada cilindro o componente.

PT

- A Special Springs é empenhada em fornecer suporte técnico para usuários; Nós fornecemos uma folha de instruções multilingue completa com cada cilindro ou componente.

Benefits

IT

- Maggiore conoscenza degli utilizzatori sui reali vantaggi offerti dai cilindri ad azoto Special Springs.
- Maggiore conoscenza degli utilizzatori sui più corretti metodi di utilizzo con vantaggi economici e di sicurezza.
- Maggiore sensibilità e coscienza sull'importanza delle sicurezze attive sui cilindri ad azoto.

EN

- Increased knowledge of users, in regards to the real benefits given by Special Springs gas springs.
- Increased knowledge of users on how to appropriately use the products, hence benefit from cost and production efficiency.
- Increased knowledge of users on the importance of our gas springs safety features.

DE

- größeres Wissen der Anwender über die effektiven Vorteile der Special Springs Gasdruckfedern.
- größeres Wissen der Anwender über die am besten geeigneten Anwendungsverfahren mit wirtschaftlichen und sicherheitsrelevanten Vorteilen.
- besseres Verständnis bzw. Bewusstsein der Wichtigkeit der aktiven Sicherheitselemente an Gasdruckfedern.

FR

- Majeure connaissance des utilisateurs sur les avantages réels offert par les ressorts à gaz Special Springs.
- Majeure connaissance des utilisateurs sur les méthodes de usage plus correctes avec avantages économiques et de sécurité.
- Majeure sensibilité et conscience sur l'importance des sécurités actives dans les ressorts à gaz.

ES

- Mayor conocimiento por parte del usuario de las ventajas ofrecidas por los cilindros Special Springs.
- Mayor conocimiento por parte del usuario de los métodos correctos para aumentar la seguridad de uso.
- Mayor sensibilidad y conciencia de la importancia de la seguridad activa en los cilindros de nitrógeno.

PT

- Aumento do conhecimento dos usuários, no que diz respeito aos benefícios reais dados pelo Cilindro de Nitrogênio Special Springs.
- Aumento do conhecimento dos usuários sobre como usar adequadamente os produtos, portanto, aumentando a eficiência de custo e produção.
- Aumento do conhecimento dos usuários sobre a importância de nossas características de segurança do cilindros de Nitrogênio.

OPERATING INSTRUCTIONS



- IT** Caricare soltanto con GAS AZOTO (N2).
- EN** Charge only with NITROGEN GAS (N2).
- DE** Gasdruckfedern dürfen nur mit STICKSTOFF GAS (N2) gefüllt werden.
- FR** Charge seulement avec du GAZ AZOTE (N2).
- ES** Cargar únicamente con GAS NITRÓGENO (N2).
- PT** Carregar somente com GÁS de NITROGÊNIO (N2).

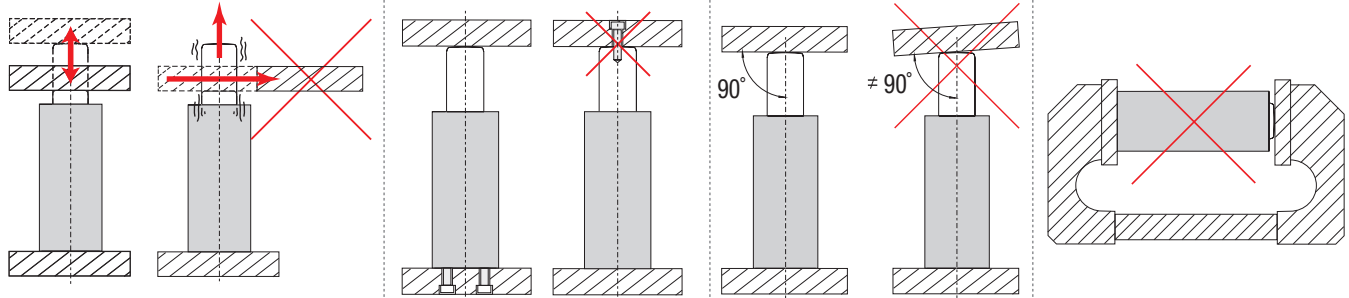

IT Tutti i cilindri Special Springs sono dotati di riserva corsa da 1 a 3 mm (escluso M90/TBM-TBI-TEM). Quindi il valore nominale Cu è completamente utilizzabile. Si raccomanda comunque di prevedere una riserva corsa addizionale pari al 10% della corsa nominale o 5mm per corse superiori a 50mm per prevenire eventuali extra-corse che potrebbero verificarsi, e causare danni irreparabili ai cilindri e gravi rischi per la sicurezza.

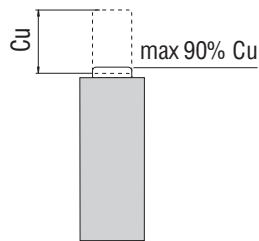

EN All Special Springs gas springs are designed with a stroke reserve from 1 to 3 mm (except M90/TBM-TBI-TEM). Thus, the nominal value Cu is fully applicable. However, it is recommended to keep a stroke reserve of 10% of the nominal stroke or 5 mm for strokes longer than 50 mm, in order to avoid the risk of any over stroke possibly causing damages to things and/or injury to people.

DE Alle Gasdruckfedern von Special Springs verfügen über eine Hubreserve von 1 bis 3 mm (Ausnahme M90/TBM-TBI-TEM). Daher kann der Nennwert Cu 100% verwendet werden. Es wird jedoch empfohlen, eine zusätzliche Hubreserve von 10% des Nennhubs bzw. 5 mm bei Hüben über 50 mm einzuhalten, um die Gefahr eines Überhubs zu vermeiden, die mögliche irreparable Beschädigungen- und/oder Personenschäden verursachen können.

FR Tous les ressorts gaz Special Springs sont conçus avec une réserve de course de 1 à 3 mm (sauf M90/TBM-TBI-TEM). Ainsi, la valeur nominale Cu est pleinement applicable. Cependant, il est recommandé de conserver une réserve de course de 10% de la course nominale ou de 5 mm pour les courses supérieures à 50 mm, afin d'éviter le risque d'une éventuelle course supplémentaire qui pourrait causer des dommages matériels et/ou corporels.

ES Todos los cilindros de gas SPECIAL SPRINGS están dotados de una reserva de carrera de 1 a 3 mm (excepto M90 / TBM-TBI-TEM). Por lo tanto el valor nominal Cu es completamente utilizable. De todos modos, se recomienda proporcionar una reserva de carrera adicional igual al 10% de la carrera nominal o 5 mm para carreras superiores a 50 mm para evitar cualquier sobre carrera que pudiera causar daños a cosas y/o lesiones a personas.

PT Todos os cilindros da Special Springs são projetados com uma reserva de curso de 1 a 3mm (exceto os modelos M90/TBM-TBI-TEM). O que permite a utilização de 100% do curso nominal do cilindro. No entanto, recomenda-se manter uma reserva de 10% do curso nominal ou 5mm para cilindros com curso superior a 50mm, para evitar o risco de sobre curso, que possa causar danos aos cilindros ou até pessoas.

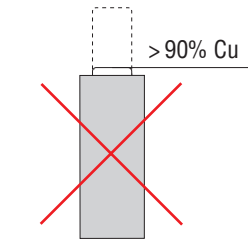

IT In presenza di contaminanti liquidi o solidi utilizzare cilindri con SKUDO. In mancanza di cilindri con SKUDO, un miglioramento significativo si ottiene installando i cilindri capovolti.

EN In presence of liquid or solid contaminants, use gas springs with SKUDO. In absence of gas springs with SKUDO protection, a significant improvement could be obtained by mounting the gas springs in upside-down position.

DE Verwenden Sie in Bereichen, in denen die Gasdruckfeder dem Einwirken von Flüssigkeiten oder Schmutzpartikeln ausgesetzt ist, Gasdruckfedern mit SKUDO. Wenn SKUDO nicht eingesetzt werden kann, empfehlen wir, die Gasdruckfeder mit nach unten stehendem Kolben zu montieren, um das Eindringen der Flüssigkeit oder der Schmutzpartikel in die Gasdruckfeder zu vermeiden.

FR En presence de contaminants liquides ou solides, utiliser les ressorts avec SKUDO. En absence de ressorts avec SKUDO, une amélioration importante peut s'obtenir en montant les cylindres renversés.

ES En presencia de contaminantes líquidos o sólidos, se recomienda el uso de cilindros con SKUDO. A falta de cilindros con SKUDO, una notable mejora se obtiene montando los cilindros boca abajo.

PT Procurar sempre utilizar cilindros com Skudo quando o mesmo for trabalhar em contato com elementos contaminantes líquidos ou sólidos. Quando não for possível a utilização dos cilindros com o Skudo, tentar fixar os cilindros de cabeça para baixo.

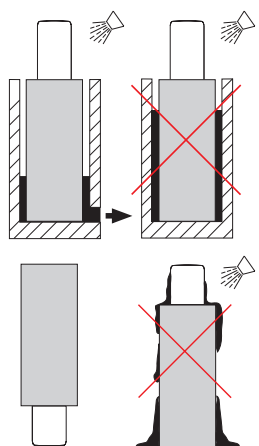

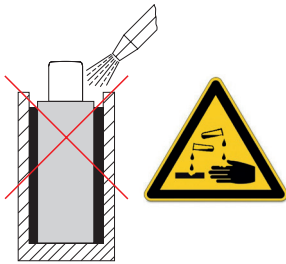

IT Evitare il contatto di fluidi aggressivi (soda e cloruri) con i cilindri. Se utilizzati per la pulizia dello stampo, si raccomanda di rimuovere dai cilindri ogni residuo.

EN Avoid any contact of gas springs with aggressive fluids (soda or chlorites). If they are used for cleaning the tools, we recommend to carefully remove any residue from gas springs.

DE Werden aggressive Flüssigkeiten (Soda oder Chloride) zur Reinigung des Bauteils verwendet, dürfen diese nicht mit den Gasdruckfedern in Kontakt kommen bzw. jeglicher Rückstand davon muss von den Gasdruckfedern entfernt werden.

FR Éviter le contact des liquides agressifs (soda ou chlorites) avec les cylindres. S'ils sont utilisés pour le nettoyage des moules, il est recommandé d'enlever tous résidus sur les cylindres.

ES Evite el contacto de fluidos agresivos (soda o cloruro) con los cilindros. Si se utilizan para la limpieza de herramientas, recomendamos eliminar cualquier residuo de los cilindros.

PT Evitar qualquer contato dos cilindros com fluidos agressivos (soda ou cloretos). Se forem usados para limpar ferramentas, recomendamos remover todos os resíduos dos cilindros.

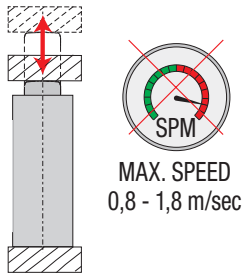

IT Non confondere la velocità massima con il numero massimo di cicli al minuto, come raccomandato per ogni modello.

EN Do not confuse the maximum speed with the maximum number of strokes per minute, as recommended for each model.

DE Die maximale Geschwindigkeit darf nicht mit der maximalen Hubzahl pro Minute verwechselt werden, wie dies für jedes Modell empfohlen wird.

FR Ne confondez pas la vitesse maximale avec le nombre maximal de coups par minute, comme recommandé pour chaque modèle.

ES No debe confundirse la velocidad máxima con el número máximo de golpes por minuto, tal como se recomienda para cada modelo.

PT Não confunda a velocidade máxima com o número máximo de golpes por minuto, conforme o recomendado para cada modelo.

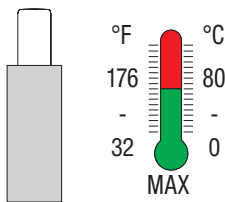

IT Temperatura di funzionamento.

EN Operating temperature.

DE Arbeitstemperatur.

FR Température de fonctionnement.

ES Temperatura de funcionamiento.

PT Temperatura de operação.

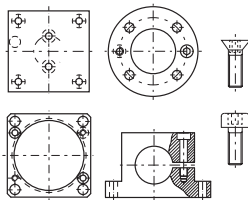

IT Si raccomanda di installare sempre i cilindri con gli appositi elementi di fissaggio.

EN It is always recommended to install the gas springs with the suitable fixing elements.

DE Es wird immer empfohlen, die Gasdruckfedern mit den geeigneten Befestigungselementen zu fixieren.

FR Il est toujours recommandé de fixer les cylindres avec les éléments de fixation appropriés.

ES Se recomienda fijar siempre los cilindros con los elementos de fijación apropiados.

PT É aconselhável fixar sempre os cilindros com os elementos de fixação adequados.

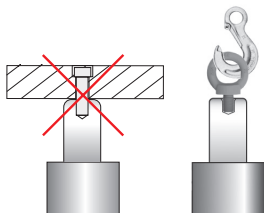

IT Utilizzare il foro filettato sullo stelo solo per la movimentazione dei cilindri.

EN Use the threaded hole on the rod only for gas springs' handling.

DE Die Gewindebohrung an der Kolbenstange ist ausschließlich für die Bewegung der Gasdruckfedern zu verwenden.

FR Utiliser le trou fileté sur la tige uniquement pour la manipulation des cylindres.

ES Utilizar el orificio roscado en el vástago solo para la manipulación de los cilindros.

PT Utilizar o furo roscado na haste só para o manuseio dos cilindros.

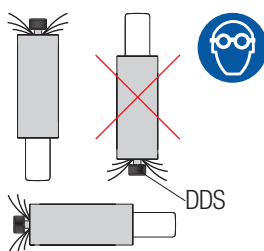

IT Durante lo scaricamento con l'uso del dispositivo DDS, orientare il flusso del gas in direzione opposta all'operatore.

EN When discharging by using a DDS device, direct the gas flow away from operator.

DE Während der Entladung mit Hilfe der DDS-Vorrichtung, richten Sie den Gasfluss in die dem Bediener entgegengesetzte Richtung.

FR Pendant le déchargement à l'aide du dispositif DDS, orientez le flux du gaz dans la direction opposée à l'opérateur.

ES Durante la descarga mediante el dispositivo DDS, orientar el flujo del gas en dirección contraria al operador.

PT Durante a descarga com a utilização do dispositivo DDS, orientar o fluxo de gás na direção oposta à do operador.

OPERATING INSTRUCTIONS

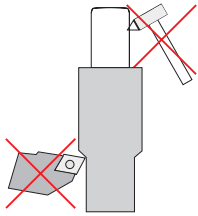

- IT** Evitare qualsiasi lavorazione meccanica o impatto su corpo e stelo.
- EN** Avoid any mechanical tooling or impact on the body and the rod.
- DE** Vermeiden Sie mechanische Bearbeitungen jeder Art oder sonstige Einwirkungen auf Körper und Kolbenstange.
- FR** Éviter toute opération mécanique ou impact sur le corps et la tige.
- ES** Evitar cualquier clase de elaboración mecánica o impacto contra cuerpo y vástago del cilindro.
- PT** Evitar qualquer trabalho mecânico ou impacto sobre o corpo e haste.



- IT** Se un cilindro ha la struttura danneggiata, prima di qualsiasi manipolazione, scaricare completamente la pressione.
- EN** If a gas spring has structural damage, fully exhaust all pressure before any form of handling.
- DE** Weist die Gasdruckfeder Beschädigungen auf, muss vor dem Eingriff der Druck vollständig abgelassen werden.
- FR** Si la structure d'un cylindre est endommagée, décharger complètement la pression, avant d'effectuer toute opération.
- ES** Si un cilindro presenta desperfectos en su estructura, descargar completamente la presión antes de proceder a revisarlo.
- PT** Se um cilindro tiver a estrutura danificada, antes de qualquer manipulação, descarregar completamente a pressão.

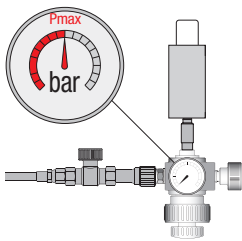

- IT** Durante il caricamento non eccedere la pressione massima raccomandata per ogni modello.
- EN** When charging do NOT exceed the maximum recommended pressure for each model.
- DE** Überschreiten Sie während der Ladung den für jedes Modell angegebenen Druckwert nicht.
- FR** Durant le chargement, il est conseillé de ne pas dépasser la pression maximum recommandée pour chaque modèle.
- ES** Durante la carga, no superar nunca la presión máxima aconsejada para cada modelo.
- PT** Durante a carga, não exceder a pressão máxima recomendada para cada modelo.

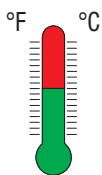

± 1 °C = ?



$$\Delta P = P_0 \times 0.33\% \times \Delta T$$

- IT** Ogni variazione della temperatura rispetto al valore nominale di calcolo di 20°C determina una variazione della pressione del gas (P).
- EN** Any variation in temperature, respect to the nominal calculation value of 20°C, causes a change in gas pressure (P).
- DE** Jede Temperatur, die vom berechneten Nennwert (20°C) abweicht, bewirkt eine Änderung des Gasdrucks (P).
- FR** Chaque modification de la température, par rapport à la valeur nominale de calcul de 20°C, détermine une modification de la pression du gaz (P).
- ES** Toda variación de temperatura con respecto al valor nominal de cálculo de 20°C, determina una variación de la presión del gas (P).
- PT** Qualquer variação da temperatura, no que respeita ao valor nominal de cálculo de 20°C, determina uma variação da pressão do gás (P).

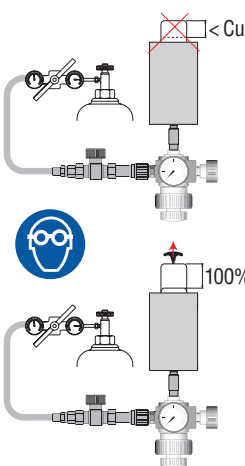

- IT** Durante il caricamento assicurarsi che lo stelo sia estratto al 100%. Per cilindri privi di foro filettato sullo stelo, caricare inizialmente con 5 bar (75 psi) per estrarre completamente lo stelo, quindi procedere fino alla pressione desiderata.
- EN** Ensure that the rod is 100% extracted when charging. For gas springs without a threaded hole on the rod, initially charge to 5 bar (75 psi) to extract the rod completely, then charge to the required pressure.
- DE** Stellen Sie vor der Befüllung der Gasdruckfeder sicher, dass die Kolbenstange ganz ausgefahren ist. Befüllen Sie Gasdruckfedern ohne Gewinde am Ende der Kolbenstange anfangs nur mit 5 bar (75 psi), um die Kolbenstange vollständig in die ausgefahrene Position zu drücken. Steigern Sie anschließend den Befülldruck auf den gewünschten Wert.
- FR** Durant le chargement, s'assurer que la tige soit complètement sortie. Les cylindres sans trou fileté sur la tige doivent être chargés initialement avec 5 bars (75 psi) pour extraire complètement la tige; procéder ensuite jusqu'à la pression désirée.
- ES** Durante la carga, asegurarse de que el vástago esté extraído al 100%. En cilindros con vástago sin orificio roscado, comenzar con una carga de 5 bar (75 psi) al fin de extraer completamente el vástago. Sólo entonces proseguir cargando hasta alcanzar la presión deseada.
- PT** Durante a carga, assegure-se de que o haste esteja totalmente extraído. Para cilindros sem orifício roscado no haste, carregar inicialmente com 5 bar (75 psi) para extrair completamente haste, depois, proceder até à pressão desejada.



- IT** Prima di gettare i cilindri ad azoto scaricare completamente la pressione.
- EN** Before disposing a gas spring ensure that all residual pressure is fully exhausted.
- DE** Vor der Entsorgung muss jede Gasdruckfeder vollständig vom Druck entleert werden.
- FR** Décharger complètement la pression, avant de jeter tout cylindre à gaz.
- ES** Nunca tirar un cilindro de gas sin antes haber descargado por completo la presión.
- PT** Antes de deitar fora qualquer cilindro a gás, descarregar completamente a pressão.

LASER MARKING

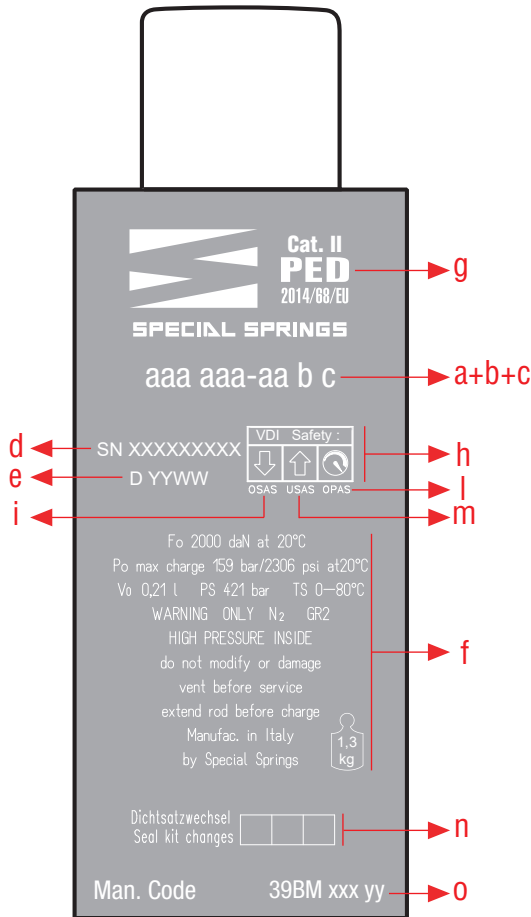

IT

- Codice modello
- Indice revisione
- Nessuna lettera = Cilindro autonomo
E = Easy Manifold
- Lotto di produzione
- Data di produzione
- Info generali
- Categoria PED
- Pittogrammi sicurezza
- Sicurezza attiva oltre corsa
- Sicurezza attiva oltre pressione
- Sicurezza attiva ritorno incontrollato
- Numero cambi guarnizione
- Kit manutenzione

EN

- Model code
- Revision indicator
- Nessuna lettera = Cilindro Autonomo
E = Easy Manifold
- Batch number
- Production date
- General info
- PED Category
- Safety pictograms
- Over stroke active safety
- Over pressure active safety
- Uncontrolled speed active safety
- Number of seal replacements
- Maintenance kit

DE

- Modellcode
- Revisionsindex
- Keine Buchstabe = Eingeständig Gasdruckfeder
E = Easy Manifold
- Produktionsserie
- Herstellungsdatum
- Allgemeine Informationen
- PED Kategorie
- Sicherheitspiktogramme
- Aktive Überhubsicherung
- Aktive Überdrucksicherheitsvorrichtung
- Aktiver Schutz bei unkontrolliertem Rückhub
- Anzahl der Dichtungswechsel
- Wartungsset

FR

- Référence modèle
- N de révision
- Aucune Lettre = Cylindre Autonome
E = Easy Manifold
- Lot de production
- Date de fabrication
- Information générales
- Catégorie PED
- Pictogrammes de sécurité
- Securité active outre-course
- Securité active outre-pression
- Securité Active pour Retour Incontrôlé
- Nombre de remplacements du joints
- Set manutention

ES

- Código de modelo
- Indicador de revisión
- Ninguna Letra = Cilindro Autonomo
E = Easy Manifold
- Lote de producción
- Fecha de fabricación
- Información general
- Categoría PED
- Pictogramas de seguridad
- Seguridad activa de fin de carrera
- Seguridad activa de sobre presión
- Seguridad Activa de Retorno Incontrolado
- Número de substituciones de la junta
- Set mantenimiento

PT

- Código do modelo
- Índice de revisão
- Sem Carta = Cilindro Autonomo
E = Easy Manifold
- Lote de produção
- Data de produção
- Informações gerais
- Classe de risco PED
- Pictogramas de segurança
- Segurança ativa mecânica
- Segurança ativa sobrepessão
- Segurança para Retorno da Haste
- Número das substituições da vedação
- Manutenção de conjunto



IT Nel catalogo per tutti i modelli sono indicate sia la forza finale isotermica che politropica.

La forza finale isotermica con 100% Cu è il valore della forza calcolato in condizioni statiche.

La forza finale politropica con 100% Cu è un valore più realistico da considerare quando il cilindro ad azoto è in funzione. Proprio per questo, va calcolata caso per caso, perché soggetta a variazioni della temperatura del gas dipendenti da corsa nominale, corsa di lavoro, velocità della pressa, no. dei cicli al minuto, volume del gas, temperatura dell'ambiente e di lavoro etc.

Special Springs, a titolo informativo, indica anche i valori approssimati di forza politropica calcolati a regime termico. Per maggiori informazioni contattare Special Springs.

EN Both the isothermal and polytropic end forces are indicated in the catalog for all models.

The isothermal end force at 100% Cu is a value calculated in static conditions.

The polytropic end force, at 100% Cu is a more realistic value consider when the gas spring is working. The polytropic force changes case-by-case, since it is subject to variations in the gas temperature depending on the nominal stroke, working stroke, press speed, number of cycles per minute (SPM), volume of gas, room temperature etc.

For user information, Special Springs, indicates the approximated values of polytropic force calculated at thermal regime. For further details please contact Special Springs.

F_{1i}
isothermal
end force

DE In unserem Katalog ist für alle Gasdruckfedern sowohl die isotherme als auch die polytrope Endkraft angegeben.

Die isotherme Endkraft bei 100% Cu ist ein Wert, der unter beinahe statischen Bedingungen ermittelt worden ist.

Die polytrope Endkraft bei 100% Cu ist ein realistischerer Wert, wenn die Gasdruckfeder in Betrieb ist. Aus diesem Grund ändert sich die polytrope Kraft von Fall zu Fall, da sie Schwankungen der Gastemperatur in Abhängigkeit von Nennhub, Arbeitshub, Pressengeschwindigkeit, Hubzahl pro Minute (SPM), Gasmenge, Raumtemperatur etc. unterliegt.

Special Springs gibt jedoch zur Information auch den annähernde Wert der polytropen Kraft an, der bei stabiler Betriebstemperatur. Für weitere Informationen wenden Sie sich bitte direkt an Special Springs.

F_{1p}
Polytropic
end force

FR Pour tous les modèles, on indique sur le catalogue, soit la force finale isothermique, que celle polytrophique.

La force finale isotherme, avec 100% Cu, est une valeur calculée sur des conditions statiques.

La force finale polytrophique, avec 100% Cu, est une valeur plus réaliste à considérer lorsque le ressort à gaz fonctionne. La force polytrophique change au cas par cas, car elle est soumise aux variations de la température du gaz en fonction de la course nominale, de la course de travail, de la vitesse de la presse, du nombre de cycles par minute, du volume de gaz, de la température ambiante, etc.

Special Springs, cependant, à des buts d'information, indique aussi les valeurs approximés de la force polytrophique calculés au régime thermique. Pour tous renseignements complémentaires, contactez Special Springs.

ES Para todos los modelos se indican en el catálogo tanto la fuerza final isotérmica como la politrópica.

La fuerza final isotérmica con 100% de Cu es el valor de fuerza calculado en condiciones estáticas.

La fuerza final politrópica con 100% de Cu es un valor más realista que se debe considerar cuando el cilindro está en funcionamiento. Por esta razón esta fuerza se calcula para cada caso particular ya que está sujeta a variaciones de la temperatura del gas que dependen de la carrera nominal, carrera de trabajo, velocidad de la prensa, número de ciclos por minuto, volumen de gas, temperatura ambiente y de trabajo, etc

Special Springs sin embargo, a título informativo, indica los valores aproximados de fuerza politrópica calculados a régimen térmico. Para más información póngase en contacto con Special Springs.

PT Para todos os modelos, é indicada no catálogo tanto a força final isotérmica, que a politrópica.

A Força Final Isotérmica considerando 100% do curso, é um valor calculado teórico.

A Força Final Politrópica considerando 100% do curso, é um valor mais realista para ser considerado em condições de trabalho. A Força Politrópica irá mudar caso a caso, pois esta sujeita a variações de temperatura do gas dependendo do curso nominal, curso de trabalho, velocidade da prensa, muneross de golpes por minuto, volume do gas, temperatura ambiente, etc...

Special Springs, no entanto, para fins de informação, indica os valores aproximados da força politrópica calculados a regime térmico. Para mais informações contacte Special Springs.



$$F_0 = P \cdot S$$

- IT** Per calcolare la forza iniziale (Fo) di un cilindro ad azoto è sufficiente moltiplicare la pressione di caricamento massima (P) per l'area di tenuta, stelo o pistone, della guarnizione (S).
- EN** To calculate the initial force (Fo) of each gas spring, multiply the maximum charging pressure (P) to the area of sealing (S), rod or piston, of the gasket seal.
- DE** Zur Berechnung der Anfangskraft (Fo) einer Gasdruckfeder, muss der angegebene maximale Befülldruck (P) mit der von der Dichtung (S) abgedichteten Fläche an Kolbenstange oder Kolben multipliziert werden.
- FR** Pour calculer la force initiale (Fo) d'un cylindre à gaz, il suffit de multiplier la pression maximum de chargement (P) pour la surface de retenue, tige ou piston, du joint (S).
- ES** Para calcular la fuerza inicial (Fo) de un cilindro de gas, se multiplica la presión máxima de carga (P) por la superficie de estanqueidad, vástago o pistón, de los retenes (S).
- PT** Para calcular a força inicial (Fo) de um cilindro a gás, basta multiplicar a pressão de carga máxima (P) pela área de estanqueidade do haste/pistão, da guarnição.

Isothermal force

Metric units

$$F_{x_i} = P \cdot S \cdot \left(\frac{1}{1 - \frac{S}{V_0} \cdot C_x} \right)^n$$

Imperial units

$$F_{x_i} = P \cdot S \cdot \left(\frac{1}{1 - \frac{S}{V_0} \cdot C_x} \right)^n$$

Tab. 1

P	n
≤100 bar	1,09
150 bar	1,19
200 bar	1,31

- IT** Per calcolare la forza intermedia isoterma (Fx_i) ad una determinata corsa di lavoro (Cx) applicare la formula sostituendo i relativi valori numerici. L'esponente (n) varia in funzione della pressione di caricamento (P) come indicato nella Tab.1. Per valori intermedi di pressione è possibile calcolare il valore di (n) proporzionalmente.
- EN** To calculate the intermediate isothermal force (Fx_i) to a specific working stroke (Cx), use the formula by replacing the relative numeric values. The exponent (n) varies in function of the charging pressure (P) as indicated in Tab.1. For intermediate pressure values, it is possible to calculate the (n) value proportionally.
- DE** Zur Berechnung der isothermischen Zwischenkraft (Fx_i) bei einem bestimmten Arbeitshub (Cx) verwenden Sie die nebenstehende Formel und setzen Sie entsprechend die im Katalog angegebenen Werte ein. Der Exponent (n) ist abhängig von dem Befülldruck (P). Mit Hilfe der Angaben in der Tab.1 können Zwischenwerte des Druckes proportional berechnet werden.
- FR** Pour calculer la force intermédiaire isothermique (Fx_i) d'un ressort à gaz à une course de travail saisie (Cx), vous devez utiliser cette formule en substituant les chiffres relatifs aux valeurs numériques. L'Exposant (n) varie en fonction de la pression de chargement (P), comme montré dans le Tab.1. Pour les valeurs intermédiaires de pression, il est possible de calculer la valeur (n) de façon proportionnelle.
- ES** Para calcular la fuerza isoterma intermedia (Fx_i) para una carrera de trabajo determinada (Cx) aplicar la formula sustituyendo los valores numéricos correspondientes. El exponente (n) varia en función de la presión de carga (P) tal y como se muestra en Tab.1. Para valores intermedios de presión, es posible calcular el valor de (n) de manera proporcional.
- PT** Para calcular a força isotérmica intermediária (Fx_i) para um determinado curso de trabalho (Cx) aplicar a fórmula através da substituição dos valores numéricos relevantes. O expoente (n) varia em função da pressão de carga (P), como mostrado na Tab.1. Para os valores intermédios de pressão, é possível calcular o valor de (n) proporcionalmente.

Polytropic force

Metric units

$$F_{x_p} = P \cdot S \cdot \left(\frac{1}{1 - \frac{S}{V_0} \cdot C_x} \right)^{1,58}$$

Imperial units

$$F_{x_p} = P \cdot S \cdot \left(\frac{1}{1 - \frac{S}{V_0} \cdot C_x} \right)^{1,58}$$

- IT** Per calcolare un valore approssimato di forza intermedia politropica (Fx_p) ad una determinata corsa di lavoro (Cx) applicare la formula sostituendo i relativi valori numerici. L'esponente (n) per la forza politropica può essere assunto pari a 1,58 per la maggior parte delle normali applicazioni.
- EN** To calculate the approximated value of polytropic intermediate force (Fx_p) to a specific working stroke (Cx), use the formula by replacing the relative numeric values. The exponent (n) for the polytropic force shall be assumed to be equal to 1,58 for the majority of normal applications.
- DE** Zur Berechnung der ungefähren polytropischen Zwischenkraft (Fx_p) bei einem bestimmten Arbeitshub (Cx) verwenden Sie die nebenstehende Formel und setzen Sie entsprechend die im Katalog angegebenen Werte ein. Der Exponent (n) beträgt im Normalfall 1,58.
- FR** Pour calculer la valeur de force polytrophique intermédiaire (Fx_p) d'un ressort à gaz à une course de travail saisie (Cx), vous devez utiliser cette formule en substituant les chiffres relatifs aux valeurs numériques. L'Exposant (n) peut être assumé comme 1,58 pour la majorité d'utilisations courantes.
- ES** Para calcular un valor aproximado de la fuerza intermedia politrópica (Fx_p) para una carrera de trabajo determinada (Cx), aplicar la formula sustituyendo los valores numéricos correspondientes. Se puede asumir un valor de 1,58 para el exponente (n) de la fuerza politrópica para la mayoría de las aplicaciones normales.
- PT** Para calcular um valor aproximado da força intermediária politrópica (Fx_p) para um determinado curso de trabalho (Cx), aplicar a fórmula através da substituição dos valores numéricos relevantes. O expoente (n) para a força politrópica pode ser assumido como sendo igual a 1,58 para a maioria das aplicações normais.

$$P_n = \frac{F_n}{S}$$

IT Per determinare la pressione di caricamento necessaria per ottenere una forza (Fn) diversa dalla nominale (Fo) è sufficiente dividere la forza richiesta (Fn) per l'area di tenuta, stelo o pistone, della guarnizione.

EN To determine the pressure level required to achieve a force (Fn) different from the nominal one (Fo), divide the required force (Fn) by the area of sealing, rod or piston, of the gasket seal.

DE Zur Berechnung des benötigten Befülldruckes (Pn) für eine spezifische Anfangskraft (Fn), die von der im Katalog angegebenen Anfangskraft abweicht, muss die gewünschte Anfangskraft (Fn) durch die von der Dichtung abgedichteten Fläche an der Kolbenstange oder Kolben dividiert werden.

FR Pour calculer la pression de chargement nécessaire pour obtenir une force (Fn) différente de la force nominale (Fo) il suffit de diviser la force requise (Fn) par la surface d'étanchéité (tige ou piston) du joint.

ES Para calcular la presión de carga necesaria para obtener una fuerza (Fn) distinta de la nominal (Fo), se divide la fuerza requerida (Fn) entre el área de estanqueidad, vástago o pistón, de los retenes.

PT Para determinar a pressão de carga necessária para obter uma força (Fn) diferente da nominal (Fo), basta dividir a força necessária (Fn) pela área de estanquidade do embolo/pistão, da guarnição.

Max Speed

IT Non superare la velocità massima dello stelo indicata. Velocità superiori possono ridurre la durata dei cilindri.

EN Do not exceed the maximum rod speed indicated. Exceeding speeds can reduce the gas spring's life.

DE Die angegebene max. Geschwindigkeit der Kolbenstange darf nicht überschritten werden. Höhere Geschwindigkeiten können die Lebensdauer der Gasdruckfedern reduzieren.

FR Ne pas excéder la vitesse maximale de la tige indiquée pour chaque modèle. Les vitesses supérieures peuvent réduire la durée des vérins.

ES No exceder la velocidad máxima del vástago indicada para cada modelo. Velocidades más altas pueden reducir la vida útil del cilindro.

PT Não exceda a velocidade máxima da haste indicada para cada modelo. Velocidades mais elevadas podem reduzir a vida útil do cilindro.

SPM Strokes per Minute

IT Per ogni modello è indicato il campo di frequenza massima di utilizzo raccomandata al 100% Cu. Il valore inferiore è riferito alla corsa più lunga, quello superiore alla corsa più breve. Frequenze superiori possono ridurre la durata dei cilindri.

EN The maximum frequency range of use recommended to 100 % Cu is indicated for every model. The lower value is referred to the longest stroke, the higher value refers to the shortest stroke. Higher frequencies can reduce the gas spring duration.

DE Für jeden Typ ist eine empfohlene max. Hubzahl (SPM) unter Berücksichtigung des max. Hubes (Cu) angegeben. Der kleine Wert bezieht sich auf den größten auswählbaren Hub, während der größere Wert sich auf den kleinsten auswählbaren Hub bezieht. Höhere Hubzahlen reduzieren die Lebensdauer der Gasdruckfedern.

FR Pour chaque modèle, on indique le champ de fréquence maximale d'usage recommandé au 100% de Cu. La valeur inférieure se réfère à la course plus longue, tandis que la valeur inférieure à la course plus courte. Fréquences supérieures peuvent réduire la durée des vérins.

ES Para cada modelo se indica el rango de frecuencia máxima de uso recomendada al 100% Cu. El valor inferior indicado es válido para carrera más larga, mientras que el valor superior se es válido para la carrera más corta. Frecuencias superiores pueden reducir la vida útil de los cilindros.

PT Para cada modelo se indica o intervalo de frequência máxima do uso recomendada al 100% Cu. O valor mais baixo é relatado para o curso mais longo, o mais elevado para o curso mais curto. frequências mais elevadas podem reduzir a duração dos cilindros.

CE
PED
2014/68/EU

IT TUTTI i cilindri ad azoto SPECIAL SPRINGS soddisfano i requisiti previsti dalla Direttiva Europea sulle attrezzature a pressione 2014/68/EU, che si applica nell'Unione Europea dal 19 Luglio 2016. Questa Direttiva regola e definisce come attrezzature a pressione i recipienti, le tubazioni e gli accessori sottoposti a una pressione massima ammissibile PS superiore a 0,5 bar. Più specificatamente, la Direttiva 2014/68/EU prevede la classificazione in categorie e l'obbligo di marcatura CE con il numero identificativo del produttore per le attrezzature il cui risultato della pressione P (bar) x il volume del fluido Vo (dm³) sia pari o superiore a 50. La marcatura CE è obbligatoria per le Categorie I, II e III. Per tutti i cilindri ad azoto il cui prodotto P x Vo è inferiore a 50 si applica l'Articolo 4.3 della Direttiva e non sono marcati CE.

EN ALL Special Springs gas springs fulfill the requirements of the European directive concerning pressure equipment (2014/68/EU), applied in the European Union from 19th July 2016. This directive sets out the standards for pressure equipment and defines them as vessels, piping and accessories subject to a maximum allowable pressure PS greater than 0,5 bar. In particular, according to the directive 2014/68/EU, pressure equipments are classified by category and they shall bear the CE marking with the identification number of the manufacturer when the result of pressure P(bar) X fluid volume Vo(dm³) is 50 or more. The CE marking is mandatory for Categories I, II and III. All gas springs which result of P x Vo is less than 50 are subject to Article 4.3 of the same directive and they do not bear the CE marking.

DE Alle Stickstoff-Gasdruckfedern von Special Springs erfüllen die Anforderungen der ab dem 19. Juli 2016 in der Europäischen Union anzuwendenden Richtlinie 2014/68/EU über die Druckgeräte. Diese Richtlinie legt die Anforderungen an die Druckgeräte fest und definiert diese als Behälter, Rohrleitungen und Ausrüstungsteile mit einem max. zulässigen inneren Überdruck (PS) von mehr als 0,5 bar. Im Einzelnen werden Druckgeräte gemäß der Richtlinie 2014/68/EU in Kategorien eingestuft und müssen mit der CE-Kennzeichnung und der Identifikationsnummer des Herstellers beschriftet werden, wenn der errechnete Wert des Produktes von Druck (P) multipliziert mit dem Befüllungsvolumen Vo (dm³) größer als 50 ist. Die CE-Kennzeichnung ist für die Kategorien I, II und III zwingend. Die Gasdruckfedern, bei denen der errechnete Wert des Produktes von Druck (P) multipliziert mit dem Befüllungsvolumen Vo (dm³) kleiner als 50 ist, tragen gemäß dem Artikel 4.3 der genannten Richtlinie keine CE-Kennzeichnung.

FR TOUS les cylindres-ressorts à l'azote de SPECIAL SPRINGS satisfont aux prescriptions de la Directive Européenne sur les équipements sous pression 2014/68/EU, qui s'applique dans l'Union Européenne depuis le 19 juillet 2016. Cette Directive fixe les exigences envers les équipements sous pression et les définit comme les récipients, les tuyauteries et les accessoires soumis à une pression maximale admissible PS supérieure à 0,5 bar. Plus spécifiquement, la Directive 2014/68/EU prévoit la classification en catégories et l'obligation du marquage CE avec le numéro d'identification du fabricant pour les équipements dont le résultat de la pression P (bar) X le volume du fluide Vo (dm³) est de 50 ou plus. Le marquage CE est obligatoire pour les catégories I, II et III. Tous les cylindres-ressorts à l'azote dont le produit de P X Vo est moins de 50 sont réglementés par l'article 4.3 de la même directive et ne portent pas le marquage CE.

ES TODOS los cilindros de nitrógeno SPECIAL SPRINGS cumplen con los requerimientos de la Directiva Europea sobre equipos a presión 2014/68/EU, que se aplica en toda la Unión Europea a partir del 19 de julio de 2016. Esta Directiva regula y define como equipos a presión los recipientes, mangueras y accesorios sometidos a una presión máxima admisible PS superior a 0,5 bar. Más concretamente, la directiva 2014/68/EU prevé la clasificación en categorías y la obligación de marcado CE con el número identificativo del fabricante para los equipos cuyo resultado de la presión P (bar) x el volumen del fluido Vo (dm³) sea igual o superior a 50. El marcado CE es obligatorio para las categorías I, II y III. Todos los cilindros de nitrógeno cuyo resultado P x Vo es inferior a 50 están sujetos al artículo 4.3 de la directiva y no llevan el marcado CE.

PT TODOS os cilindros de nitrogénio Special Springs satisfazem os requisitos da Diretiva Europeia para equipamentos sob pressão 2014/68/EU, que se aplica na União Europeia a partir de 19 de julho de 2016. Esa Diretiva regulamenta os equipamentos sob pressão e os define como os recipientes, os tubagens e os acessórios sujeitos a uma pressão máxima admissível PS superior a 0,5 bar. Em particular, a directiva 2014/68/EU prevê a classificação em categorias e a obrigação da marcação CE com o número de identificação do fabricante para os equipamentos cujo o resultado de pressão P (bar) X volume fluido Vo(dm³) é igual ou superior a 50. A marcação CE é obrigatória para as categorias I, II e III. Todos os cilindros de nitrogénio, através da qual resultam P x Vo é inferior a 50 estão sujeitos ao artigo 4.3 da mesma directiva e não ostentam a marcação CE.

IT SPECIAL SPRINGS garantisce che i cilindri ad azoto prodotti e venduti da SPECIAL SPRINGS sono privi di difetti di fabbricazione. La presente Garanzia è valida per un periodo di (2) due anni dalla data di acquisto, o per **200.000 metri lineari** di corsa*, o per **2.000.000 di cicli**, a seconda di quale condizione si verifichi per prima. (***100.000 metri lineari** per la Serie HT)

La Garanzia si applica solo ai cilindri ad azoto installati, utilizzati e riparati secondo le prescrizioni SPECIAL SPRINGS.

In caso di presunto difetto, tutte le informazioni utili – comprese la data di acquisto e le condizioni di utilizzo dei cilindri – dovranno essere notificate a SPECIAL SPRINGS.

Prima di utilizzare i cilindri ad azoto SPECIAL SPRINGS, si raccomanda di fare sempre riferimento alle informazioni sulla sicurezza e sul rispetto delle normative come indicato nel Foglio Istruzioni, nella documentazione tecnica e/o nel sito web www.specialsprings.com.

Per "GARANZIA" si intende la riparazione o la sostituzione gratuita del prodotto riconosciuto da SPECIAL SPRINGS come difettoso nella fabbricazione o nel materiale.

SPECIAL SPRINGS non risponde di eventuali danni causati da negligenza, uso improprio e mancato rispetto delle avvertenze e indicazioni contenute nelle prescrizioni SPECIAL SPRINGS.

Si noti infine che condizioni di lavoro critiche o cause esterne possono ridurre significativamente la durata dei cilindri ad azoto.

Termini legali di garanzia su www.specialsprings.com

EN SPECIAL SPRINGS guarantees that the gas springs manufactured and sold by SPECIAL SPRINGS are free from manufacturing defects. This Warranty is valid for the period of (2) two years from the date of purchase, or for **200,000 linear meters** of stroke*, or for **2,000,000 strokes**, whichever occurs first. (***100,000 linear meters** for the HT Series)

The Warranty is applicable only to gas springs installed, used, and repaired according to SPECIAL SPRINGS guidelines.

In case of alleged defect, all useful information - including the date of purchase and the working conditions of gas springs - shall be notified to SPECIAL SPRINGS.

Before using SPECIAL SPRINGS gas springs, always refer to the information on the safety and the compliance with regulations as indicated in the Instruction Sheet, the technical documentation and/or on the website www.specialsprings.com.

By "WARRANTY" it is meant the repair or free replacement of the product, which is recognized by SPECIAL SPRINGS as defective in manufacture or materials.

SPECIAL SPRINGS is not liable for any damage caused by negligence, misuse and noncompliance with the warning and indications contained in SPECIAL SPRINGS guidelines.

Furthermore, heavy working conditions or external causes may reduce the lifetime of gas springs significantly.

Warranty legal terms on www.specialsprings.com

DE SPECIAL SPRINGS garantiert, dass die von SPECIAL SPRINGS hergestellten und verkauften Gasdruckfedern frei von Herstellungsfehlern sind. Diese Garantie gilt für einen Zeitraum von (2) zwei Jahren ab Kaufdatum oder für **200.000 m Gesamthub*** oder für **2.000.000 Hübe**, je nachdem, was zuerst eintritt. (***100.000 m Gesamthub** für die Baureihe HT)

Die Garantie gilt nur für Gasdruckfedern, die gemäß Special Springs Richtlinien installiert, verwendet und repariert wurden.

Im Falle eines behaupteten Defekts müssen alle nützlichen Informationen - einschließlich des Kaufdatums und der Arbeitsbedingungen der Gasdruckfedern - Special Springs mitgeteilt werden.

Vor der Verwendung von SPECIAL SPRINGS-Gasdruckfedern beachten Sie immer die Informationen zur Sicherheit und Einhaltung der Vorschriften, die in der Gebrauchsanweisung, in der technischen Dokumentation und/oder auf der Website www.specialsprings.com angegeben sind.

Unter „GARANTIE“ versteht sich die Reparatur oder der kostenlose Ersatz eines Produkts, bei dem von SPECIAL SPRINGS Herstellungs- oder Materialfehler anerkannt werden.

SPECIAL SPRINGS haftet nicht für Schäden, die durch Fahrlässigkeit, Missbrauch und Nichtbeachtung von Warnungen und Hinweisen, die in den SPECIAL SPRINGS- Richtlinien angegeben sind, entstanden sind.

Schwere Arbeitsbedingungen oder äußere Ursachen können die Lebensdauer von Gasdruckfedern erheblich verkürzen.

Garantiebedingungen siehe www.specialsprings.com

LIFE WARRANTY



LIFE WARRANTY



FR SPECIAL SPRINGS garantit que les ressorts à gaz fabriqués et vendus par SPECIAL SPRINGS sont exempts de défauts de fabrication. Cette garantie est valable pour une période de (2) deux ans à compter de la date d'achat, ou pour **200.000 mètres linéaires** de course*, ou pour **2.000.000 de courses**, selon la première éventualité. (***100 000 mètres linéaires** pour la série HT).

La garantie ne s'applique qu'aux ressorts à gaz installés, utilisés et réparés conformément aux directives de SPECIAL SPRINGS.

En cas de défaut présumé, toutes les informations utiles - y compris la date d'achat et les conditions de travail des ressorts à gaz - doivent être communiquées à SPECIAL SPRINGS.

Avant d'utiliser les ressorts à gaz SPECIAL SPRINGS, il faut toujours se référer aux informations relatives à la sécurité et au respect des réglementations indiquées dans la fiche d'instructions, la documentation technique et/ou sur le site www.specialsprings.com.

Par "GARANTIE" on entend la réparation ou le remplacement gratuit du produit, reconnu par SPECIAL SPRINGS comme présentant un défaut de fabrication ou de matériaux.

SPECIAL SPRINGS n'est pas responsable des dommages causés par la négligence, la mauvaise utilisation et le non-respect des avertissements et indications contenus dans les directives de SPECIAL SPRINGS.

En outre, des conditions de travail difficiles ou des causes externes peuvent réduire considérablement la durée de vie des ressorts à gaz.

Conditions légales de garantie sur www.specialsprings.com

ES SPECIAL SPRINGS garantiza que los cilindros de gas producidos y vendidos por SPECIAL SPRINGS están libres de defectos de fabricación. Esta Garantía es válida por un período de (2) dos años a partir de la fecha de compra, o para **200.000 metros lineales** de carrera*, o para **2.000.000 de golpes**, lo que ocurra primero. (***100.000 metros lineales** por la Series HT)

La Garantía se aplica solo a los cilindros de gas instalados, usados y reparados de acuerdo con las pautas de SPECIAL SPRINGS.

En caso de un supuesto defecto, toda las informaciones útiles – incluidas la fecha de compra y las condiciones de uso de los cilindros – deberán ser comunicadas a SPECIAL SPRINGS.

Antes de usar los cilindros de gas SPECIAL SPRINGS, consultar siempre las informaciones de seguridad y de cumplimiento normativo indicadas en la Hoja de Instrucciones, en la documentación técnica y/o en el sitio web www.specialsprings.com.

Por "GARANTÍA" se entiende la reparación o el reemplazo gratuito del producto, que SPECIAL SPRINGS reconoce como defectuoso en la fabricación o en el material.

SPECIAL SPRINGS no se hace responsable de los daños causados por negligencia, uso indebido e incumplimiento de las advertencias e indicaciones contenidas en las pautas de SPECIAL SPRINGS.

Además, condiciones de trabajo críticas o causas externas pueden reducir significativamente la vida útil de los cilindros de gas.

Términos legales de la garantía en www.specialsprings.com

PT A SPECIAL SPRINGS garante que os cilindros de nitrogenio fabricados e vendidos pela SPECIAL SPRINGS estão livres de defeitos de fabricação. Esta garantia é valida por um periodo de 2 anos a contar da data da compra, ou **200.000 metros lineares** de curso utilizado, ou por **2.000.000 de golpes**, o que ocorrer primeiro. (**100.000 metros lineares** para cilindros da Linha HT).

A garantia é valida somente para cilindros instalados, utilizados ou reparados de acordo com as recomendações da SPECIAL SPRINGS.

Em caso de possível defeito, todas as informações necessárias - incluindo a data da compra e as condições de trabalho, deverão ser informadas a SPECIAL SPRINGS.

Antes de iniciar a utilização dos cilindros de nitrogenio da SPECIAL SPRINGS, é recomendado que verifique todas as informações sobre segurança e normas de utilização contidas no folheto de instrução, na documentação tecnica e ou no site www.specialsprings.com.

A "GARANTIA" significa a troca de reparos ou a substituição do produto, em casos reconhecidos pela SPECIAL SPRINGS como um defeito de fabricação ou de matéria prima.

A SPECIAL SPRINGS não se responsabiliza por qualquer defeito causado defeito causado por negligencia, mal uso do produto ou o não obediencia com os cuidados e indicações de uso contidas no manual de utilização da SPECIAL SPRINGS.

Alem disso, condições extremas ou causas externas podem reduzir a vida util dos cilindros de nitrogenio consideravelmente.

Termos legais de garantia, podem ser encontrados no site www.specialsprings.com

IT Qualora, dopo un lungo funzionamento o per applicazioni particolarmente gravose, si verificassero delle perdite di pressione, significa che le tenute hanno iniziato ad usurarsi o sono state danneggiate. E' quindi possibile, con l'uso di appositi utensili e kits ed il supporto di specifici video e dettagliate istruzioni, ripristinare le condizioni originarie di tenuta e guida. La manutenzione deve essere eseguita solamente da personale qualificato. Eventuali errori possono essere causa di gravi rischi per la sicurezza o limitare la durata dei cilindri. Prima di eseguire qualsiasi intervento scaricare completamente la pressione e assicurare che lo stelo sia completamente compresso nel corpo.

EN If pressure losses occur after extended use or particularly heavy applications, this indicates that the sealing gaskets are worn or damaged. Using special tools and kits, and with the support of videos and detailed instructions, it is possible to restore the original seal and guide conditions. Maintenance must only be conducted by qualified personnel. Errors would cause serious injury or reduce the working life of the gas springs. Before carrying out any work on the system, fully exhaust all pressure and ensure that the rod is fully retracted into the body.

DE Wird nach langer Betriebstätigkeit oder besonders beanspruchender Verwendung ein Druckverlust festgestellt, bedeutet dies, dass die Dichtungen allmählich abgenutzt sind oder beschädigt wurden. Es ist mit Hilfe von zweckmäßigem Werkzeug oder Sets sowie spezifischen Videos und detaillierten Anweisungen möglich, die Ausgangsbedingungen von Dichtung und Führung wiederherzustellen. Die Wartung sollte nur von qualifiziertem Personal vorgenommen werden. Etwaige Fehler können schwerwiegende Sicherheitsrisiken hervorrufen oder die Lebensdauer der Zylinder einschränken. Entladen Sie den Druck und stellen Sie sicher, dass die Kolbenstange komplett in den Zylinderkörper eingeführt ist, bevor Sie Eingriffe vornehmen.

FR Si des pertes de pression se produisent après un long fonctionnement ou avec des applications particulièrement lourdes, cela signifie que les joints de rétenue ont commencé à s'user ou qu'ils sont endommagés. L'utilisation d'outils et de kits appropriés, ainsi que le support de vidéos spécifiques et d'instructions détaillées permettront de rétablir les conditions d'origine de rétenue et de guidage. La maintenance doit être effectuée uniquement par du personnel qualifié. Les éventuelles erreurs peuvent engendrer de graves risques pour la sécurité ou limiter la durée de vie des cylindres. Avant d'effectuer toute opération, décharger complètement la pression et s'assurer que la tige soit complètement comprimée dans le corps.

ES Si después de un largo funcionamiento o en caso de aplicaciones especialmente difíciles se produjesen pérdidas de presión, podría deberse a que los retenes han comenzado a desgastarse o han sufrido algún desperfecto. En esos casos es perfectamente posible restablecer las condiciones originales de los retenes o del guiado mediante kits de mantenimiento adecuados y videos con instrucciones específicas. El mantenimiento debe ser efectuado única y exclusivamente por personal cualificado. Cualquier error podría causar graves riesgos de seguridad o limitar la vida útil de los cilindros. Antes de cualquier reparación, descargar completamente la presión y asegurarse de que el vástago quede completamente comprimido dentro del cuerpo.

PT Depois de muito tempo de utilização dos cilindros, ou trabalhando em condições severas, os cilindros podem apresentar perda de pressão, isto significa que os elementos vedantes começaram a se desgastar ou estão danificados. Neste caso é possível fazer a troca dos elementos vedantes, mas só deve ser feito com a utilização dos instrumentos e ferramentas corretas, auxílio de videos de treinamento e manual de instrução. A manutenção só deve ser feita por pessoal qualificado. A manutenção incorreta dos cilindros pode causar graves riscos de operação e limitar a vida útil dos cilindros. Antes de executar qualquer intervenção nos cilindros, assegurar que os cilindros estão completamente descarregados.

Download step-by-step guide instructions at: <http://www.specialsprings.com>

IT Come previsto dalle linee guida della direttiva PED 2014/68/EU l'azienda che provvede alla manutenzione dei cilindri marcati CE dal fabbricante (P x Vo \geq 50) si assume la completa responsabilità di far riesaminare gli stessi da un ente di certificazione accreditato. Diversamente tali manutenzioni potranno essere effettuate esclusivamente da Special Springs.

EN As prescribed by the guidelines of PED 2014/68/EU, the company taking care of the maintenance for gas springs laser marked CE by the producer (P x Vo \geq 50), must get them checked by a certified body. Otherwise, the maintenance can be carried out exclusively by Special Springs.

DE Wie in der Richtlinie PED 2014/68/EU vorgeschrieben übernimmt die Firma, die die Instandhaltung von Gasdruckfedern durchführt, die vom Hersteller mit CE-Kennzeichnung versehen worden sind (P x Vo \geq 50), die volle Verantwortung dafür, diese von einer zugelassenen Zertifizierungsanstalt nachprüfen zu lassen. Andernfalls können diese Instandhaltungsarbeiten ausschließlich von Special Springs durchgeführt werden.

FR Selon le mode prévu par les indications de la directive PED 2014/68/EU, l'entreprise qui s'occupe de l'entretien des cylindres marqués CE par le producteur (P x Vo \geq 50), assume la responsabilité de les faire réexaminer par un institut de certification qualifié. Autrement, les entretiens peuvent être effectués exclusivement par Special Springs.

ES Tal y como prevén las directrices de la directiva PED 2014/68/EU, la empresa que realiza mantenimiento de cilindros marcados CE por el fabricante (P x Vo \geq 50) asume la completa responsabilidad de que sean posteriormente verificados por un ente certificado. De otro modo tales tareas de mantenimiento sólo podrán ser llevadas a cabo por Special Springs.

PT De acordo com as directrizes PED 2014/68/EU a fabrica que fornece a manutenção dos cilindros com a marca CE do fabricante (P x Vo \geq 50) assume a responsabilidade de reexaminar os mesmos por uma entidade de certificação creditada. De outra forma tais manutenções poderão ser efectuadas exclusivamente pela Special Springs.



PED
2014/68/EU





How to Order



Maintenance kits

- IT** Se presente nel cilindro ad azoto, riportare il codice Man. Code in fase di ordinazione.
- EN** If Man. Code is indicated on the gas spring, specify it on the order.
- DE** Wenn Man. Code auf der Gasdruckfeder vorhanden, bitte in der Bestellung angeben.
- FR** Si le Man. Code est indiqué en le cylindre, précisez-le dans l'ordre.
- ES** Si el Man. Code está indicado en el cilindro, especificarlo en el pedido.
- PT** Se indicado no cilindro, indique o Man. Code na ordem.

EXAMPLE: 39BMNML00063A

- IT** Se il codice Man. Code non è riportato sul cilindro ad azoto: 39BM + Codice cilindro completo.
- EN** If Man. Code is not indicated on the gas spring, order: 39BM + complete Part Number.
- DE** Wenn Man. Code auf der Gasdruckfeder nicht vorhanden, bestellen Sie 39BM + vollständige Artikelnummer.
- FR** Si le Man. Code n'est pas indiqué en le cylindre, ordonnez 39BM + Numéro d'Article complet.
- ES** Si el Man. Code no está indicado en el cilindro, pedir 39BM + Código completo del Producto.
- PT** Se a referencia Man Code não estiver escrita no cilindro, favor solicitar 39BM + Código do Produto completo.

EXAMPLE: 39BMNML00063-063 A

- IT** Kit include: Boccola assemblata, Valvola unidirezionale, lubrificante e grasso, Istruzioni di montaggio.
- EN** Kit contains: Assembled bushing, one way valve, lubricant and grease, Instructions sheet.
- DE** Das Set beinhaltet: montierte Buchse, Rückschlagventil, Schmieröl und Schmierfett, Montageanleitung.
- FR** Le kit comprend: Douille assemblée, Soupape unidirectionnelle, lubrifiant, graisse et les instructions pour le montage.
- ES** El Kit contiene: casquillo ensamblado, Válvula unidireccional, lubricante y grasa, Instrucciones de montaje.
- PT** O kit contém: Bucha montada, válvula unidireccional, lubrificante, graxa e instruções de montagem.



- IT** Special Springs rende sempre disponibili i manuali d'uso dei propri prodotti (in forma cartacea o scaricabili da web tramite QR-Code). Consegnare sempre i manuali insieme alle attrezzature che contengono prodotti Special Springs.
- EN** Special Springs always provides user manuals for its products (in printed form or downloadable from the web via QR-Code). It is important to always deliver the manuals together with the equipment containing Special Springs products.
- DE** Special Spings stellt immer für die eigenen Produkte die Bedienungsanleitungen - in der gedruckten Version oder durch Internet Seite mittels QR-Codes herunterladen -zur Verfügung. Wichtig: die Bedienungsanleitungen sind immer der Geräte beizulegen, welche mit Special Springs Produkte ausgerüstet sind.
- FR** Special Springs fournit toujours des manuels d'utilisation pour ses produits (sous forme imprimée ou téléchargeable sur le Web via QR-Code). Il est important de toujours livrer les manuels avec l'équipement contenant les produits Special Springs.
- ES** Special Springs siempre proporciona manuales de usuario para sus productos (en forma impresa o descargables desde la web a través de QR-Code). Es importante entregar siempre los manuales junto con los equipos que contengan productos Special Springs.
- PT** A Special Springs fornece sempre manuais de usuário dos seus produtos (em formato impresso ou por download na web via QR-Code). É importante entregar sempre os manuais junto com os equipamentos que contenham produtos Special Springs.



HOW TO READ THE CATALOG



1

NMX 32



2



* F_{1i} =

Isothermal end force at 100% Cu

** F_{1p} =

Polytrophic end force at 100% Cu

ACTIVE SAFETY



OSAS



USAS



OPAS

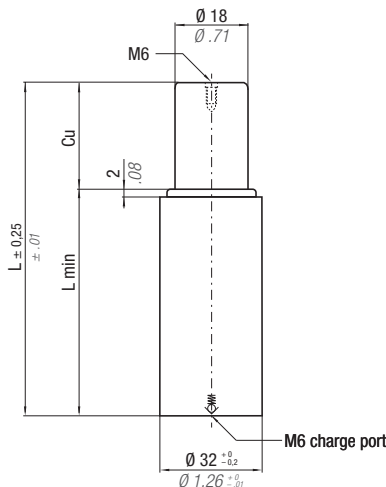

3

5

6

7

8

9

10

4



0 - 80 °C
32 - 176 °F

ΔP
± 0,33 %/°C

P max
196 bar
2842 psi

P min
20 bar
290 psi

S
2,54 cm²
0,394 in²

SPM
~ 20 - 100
(at 20°C)

Max Speed
1,8 m/s
70,8 in/s

Maintenance kit
39BMGSN00032A

11

12

13

14

15

CODE	Cu		L		L min		F ₀		F _{1i} *		F _{1p} **		V ₀		PED 2014/68/EU		
	mm	inch	mm	inch	mm	inch	daN	lb	daN	lb	daN	lb	cm ³	in ³		-Kg	-lb
NMX 32 - 010 - A	10	0.39	65	2.56	55	2.16	500	1124	662	1488	843	1895	13,0	0.79	0,23	0,51	✓
NMX 32 - 015 - A	15	0.59	75	2.95	60	2.36	± 5%		708	1592	914	2055	16,2	0.99	0,25	0,55	✓
NMX 32 - 025 - A	25	0.98	95	3.74	70	2.75	196 bar 2842 psi		768	1727	1009	2268	22,5	1.37	0,28	0,62	✓
NMX 32 - 038 - A	38	1.50	121	4.76	83	3.26	+ 20°C +68°F		814	1830	1083	2435	30,8	1.88	0,33	0,72	✓
NMX 32 - 050 - A	50	1.97	145	5.71	95	3.74			841	1891	1128	2536	38,4	2.34	0,37	0,81	✓
NMX 32 - 080 - A	80	3.15	205	8.07	125	4.92			880	1978	1192	2680	57,5	3.51	0,47	1,03	✓

16

17

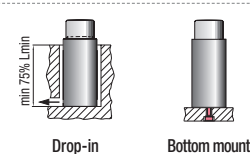

HOW TO ORDER

p. 59

INSTALLATION GUIDELINE

p. 75

62 - 024

Special Springs

18

<p>1 Modello di cilindro ad azoto Gas spring model Gasdruckfeder Modell Modèle de Ressorts à Gaz Modelo de cilindro de Gas Modelo de cilindro de nitrogênio</p>	<p>2 Raschiatore secondario applicabile Secondary Wiper can be mounted Sekundärabstreifer montierbar Joint racleur secondaire peut être monté Posibilidad de montar rascador secundario. Raspador secundário montável</p>
<p>3 Dispositivi di sicurezza presenti nel modello Safety devices provided on the model Sicherheitsvorrichtungen am Modell Dispositifs de sécurités présents sur le modèle Dispositivos de seguridad disponibles en el modelo Dispositivos de segurança disponíveis no modelo</p>	<p>4 Gas di caricamento Pressure medium Druckgas Gaz de chargement Gas de carga Gás de carga</p>
<p>5 Temperatura di esercizio Working temperature Betriebstemperatur Température de fonctionnement Temperatura de funcionamiento Temperatura de funcionamento</p>	<p>6 $\Delta P / \Delta T$</p>
<p>7 Pressione max di caricamento Max charging pressure Maximaler Ladedruck Pression de chargement maximum Presión máx de carga Pressão máxima de carga</p>	<p>8 Pressione min. di caricamento Min charging pressure Minimaler Ladedruck Pression de chargement minimum Presión mín de carga Pressão mínima de carga</p>
<p>9 Area di tenuta stelo/pistone Rod/piston seal area Dichtungsbereich Kolbenstange/Kolben Zone d'étanchéité tige/piston Área de estanqueidad vástago/pistón Área de estanquidade do embolo/pistão</p>	<p>10 Cicli / minuto Strokes / minute Hübe/Minute Cycles / minute Ciclos / minuto Pancadas / minuto</p>
<p>11 Codice Code Bestell-Nummer Référence Código Codigo</p>	<p>12 Forza iniziale a 20°C Initial force at 20°C Anfangskraft bei 20°C Force initiale à 20°C Fuerza inicial a 20°C Força inicial a 20°C</p>
<p>13 Forza finale isoterma Isothermal end force Isothermische Endkraft Force finale isothermique Fuerza final isotérmica Força final isotérmica</p>	<p>14 Forza finale politropica Polytropic end force Polytropische Endkraft force finale politrophique fuerza finale politrópica força finale politrópica</p>
<p>15 Volume iniziale Initial gas volume Anfangswert Gasvolumen Volume de gaz initial Volumen de gas inicial Volume de gás inicial</p>	<p>16 Classificazione PED PED classification PED Einstufung Classification PED Clasificación PED Classificação PED</p>
<p>17 Fissaggi Flange mounts Befestigungen Brides de fixation Bridas de fijación Fixação com flange</p>	<p>18 Indice di revisione pagina Page review index Index der Seitenüberprüfung Index de revue de page Índice de revisión de página Índice de revisão de página</p>
<p> Tutte le dimensioni senza tolleranza si intendono nominali. All dimensions are nominal unless tolerance is stated. Alle Maßangaben ohne Toleranzen sind Nennmaße.</p>	<p>Sauf specifications de tolerances, toutes les dimensions sont des valeurs nominales. Todas las dimensiones son nominales excepto cuando se indica la tolerancia. Todas as medidas são nominais excepto quando a tolerancia é mencionada.</p>

SELECTION TAB

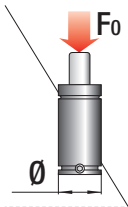

	80 100	150 170	300 360	400	500 660	700 750	1000	1500	2000	3000
16	NMS 16									
19	NMC 19	NCS 19 NMS 19 NMX 19								
25		NMC 25	NCS 25 NML 25 NMS 25 NMX 25	NT 25						
32					NCS 32 NCS 32.2 NML 32 NC 32 NMX 32	NT 32				
38						NML 38 NC 38 NMX 38	NCS 38			
50								NML 50 NMX 50	NCS 50	
63									NML 63	NCS 63
75										NML 75

THIS PAGE IS INTENTIONALLY LEFT BLANK

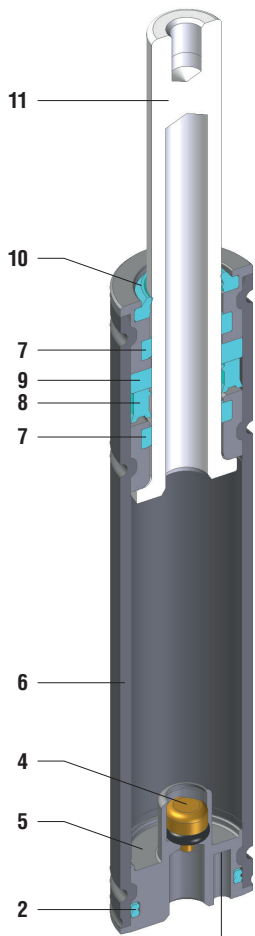

**Over
Pressure
Active
Safety**

NCS 19

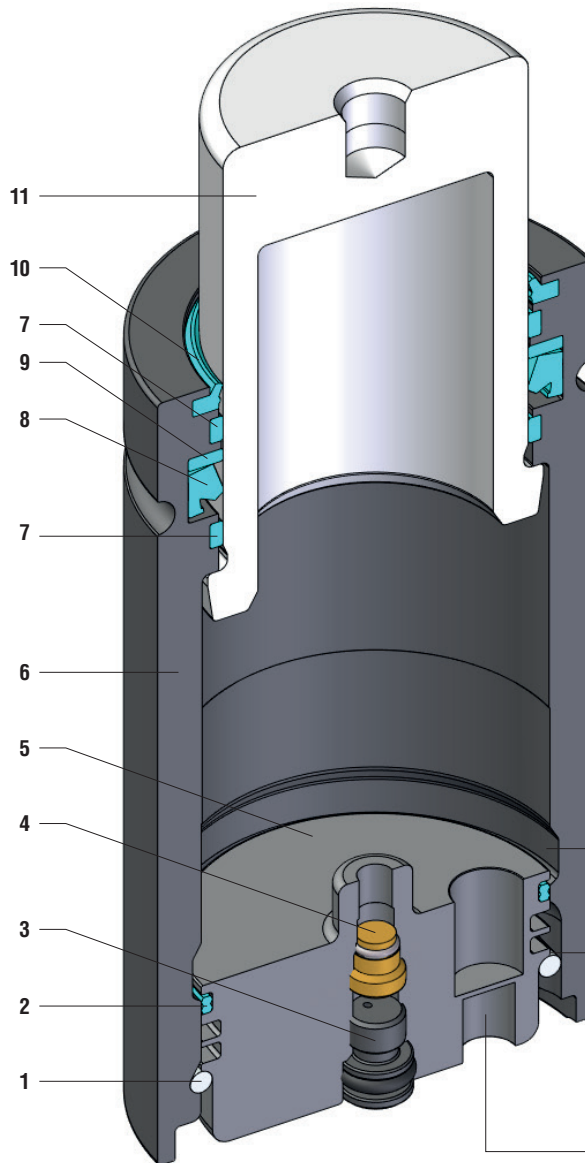

**Over
Stroke
Active
Safety**

**Uncontrolled
Speed
Active
Safety**

**Over
Pressure
Active
Safety**

NCS 25 ÷ NCS 63

SEALING	ROD SEAL
DESIGN	BOTTOM BASE - BODY DESIGN

1	Retaining ring	5	Bottom base	9	Back-up ring
2	Dual ring seal	6	Body	10	Rod wiper
3	Plug	7	Guide ring	11	Rod (nitrited superfinished)
4	Valve	8	Rod seal		

RANGE CHART

Model	Body Ø		Stroke Cu		Initial force F0					
	mm	inch	mm	inch	daN	lb	OSAS	USAS	OPAS	SW
NCS 19	19	0.75	10 - 80	0.39 - 3.15	150	337	-	-	✓	✓
NCS 25	25	0.98	10 - 80	0.39 - 3.15	300	674	✓	✓	-	✓
NCS 32	32	1.26	10 - 80	0.39 - 3.15	500	1124	✓	✓	-	✓
NCS 32.2	32	1.26	10 - 80	0.39 - 3.15	660	1484	✓	✓	-	✓
NCS 38	38	1.50	10 - 80	0.39 - 3.15	1000	2248	✓	✓	✓	✓
NCS 50	50	1.97	10 - 80	0.39 - 3.15	2010	4519	✓	✓	✓	✓
NCS 63	63	2.48	10 - 80	0.39 - 3.15	3000	6744	✓	✓	✓	✓

✓ Built-in as standard

✓ Optional upon request

NCS

HOW TO ORDER

Series _____ Revision code _____

Model **NCS50-025-A-E-W**

Stroke _____ Version _____

Available versions

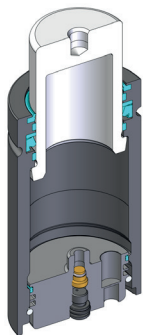

NCS 50-025-A
Standard code



Self contained

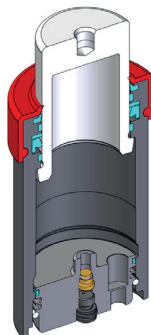

NCS 50-025-A-W
Add "-W" to standard code



Self contained

+



Secondary wiper

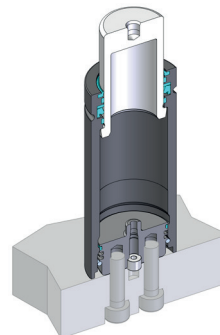

NCS 50-025-A-E
Add "-E" to standard code



Easy Manifold

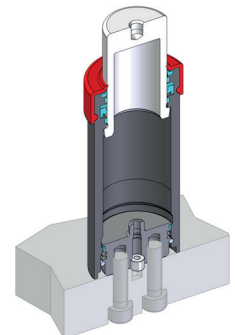

NCS 50-025-A-E-W
Add "-E-W" to standard code



Easy Manifold

+



Secondary wiper



SW

ACTIVE SAFETY



OPAS

* $F_{1i} =$

Isothermal end force at 100% Cu p. 18

** $F_{1p} =$

Polytropic end force at 100% Cu

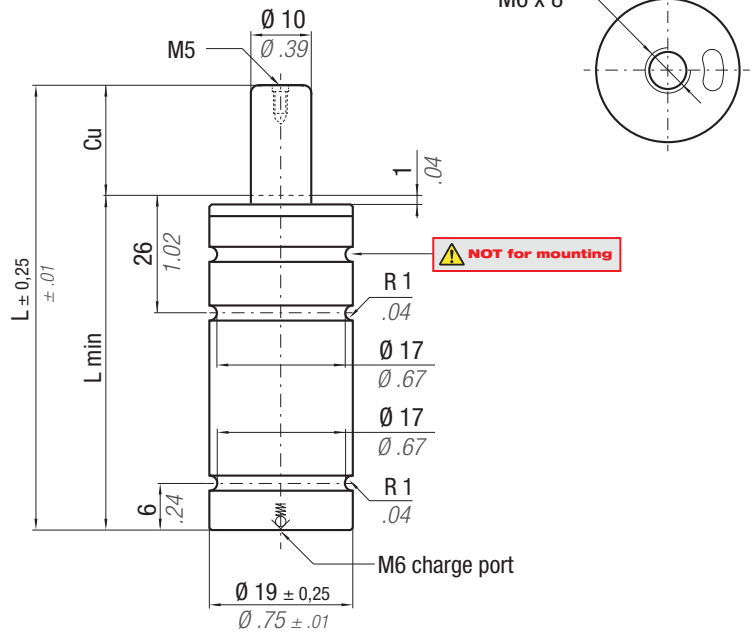

NOT for mounting

N ₂	0 - 80 °C 32 - 176 °F	ΔP ± 0,33 %/°C	P max 191 bar 2770 psi	P min 20 bar 290 psi	S 0,79 cm ² 0,122 in ²	SPM ~ 20 - 100 (at 20°C)	Max Speed 1,8 m/s 70.8 in/s	Maintenance kit Disposable
CODE	Cu	L	L min	F ₀ Initial force	F _{1i} * End force *	F _{1p} ** End force **	V ₀	
	mm inch	mm inch	mm inch	daN lb	daN lb	daN lb	cm ³ in ³	~Kg ~lb
NCS 19 - 010 - A	10 0.39	75 2.95	65 2.56	150 337 ± 5% 191 bar 2770 psi + 20°C + 68°F	185 416	232 522	5,2 0.32	0,09 0.20 ✓
NCS 19 - 015 - A	15 0.59	85 3.35	70 2.76		195 438	249 560	6,4 0.39	0,10 0.22 ✓
NCS 19 - 020 - A	20 0.79	95 3.74	75 2.95		203 456	261 587	7,5 0.46	0,10 0.22 ✓
NCS 19 - 025 - A	25 0.98	105 4.13	80 3.15		209 470	271 609	8,6 0.52	0,11 0.24 ✓
NCS 19 - 032 - A	32 1.26	120 4.72	88 3.46		214 481	278 625	10,4 0.63	0,11 0.24 ✓
NCS 19 - 038 - A	38 1.50	135 5.31	97 3.82		214 481	278 625	12,3 0.75	0,12 0.26 ✓
NCS 19 - 045 - A	45 1.77	150 5.91	105 4.13		218 490	283 636	14,1 0.86	0,13 0.29 ✓
NCS 19 - 050 - A	50 1.97	160 6.30	110 4.33		220 495	288 647	15,2 0.93	0,14 0.31 ✓
NCS 19 - 056 - A	56 2.20	175 6.89	119 4.69		220 495	287 645	17,2 1.05	0,14 0.31 ✓
NCS 19 - 063 - A	63 2.48	190 7.48	127 5.00		222 499	290 652	19,0 1.16	0,15 0.33 ✓
NCS 19 - 080 - A	80 3.15	220 8.66	140 5.51	233 524	308 692	21,7 1.32	0,17 0.37 ✓	

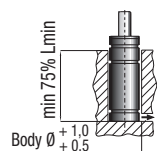

Drop-in

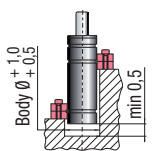

FC 19 B
FCC 19 A - FCD 19

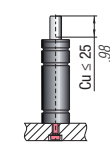

Bottom mount
FBE 19

HOW TO ORDER

p. 31

INSTALLATION GUIDELINE

p. 75



SW

ACTIVE SAFETY



OSAS



USAS

NCS

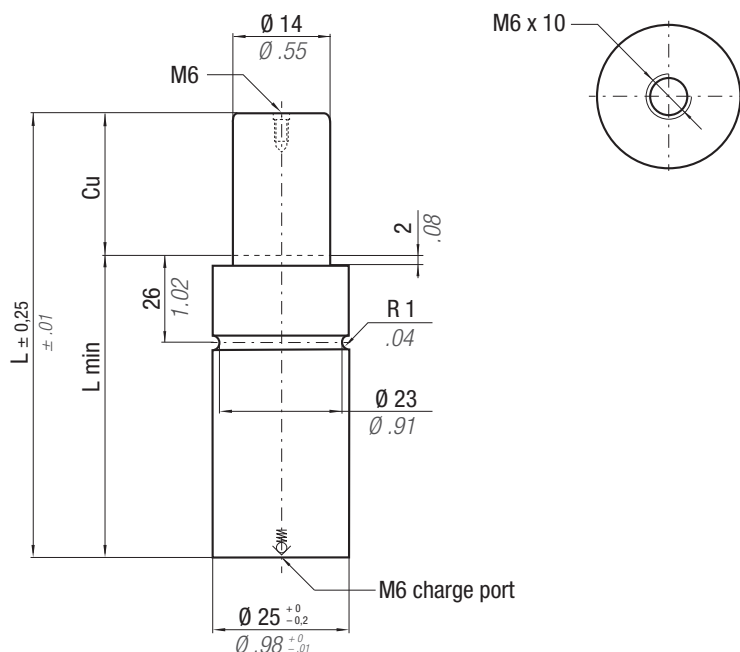

* $F_{1i} =$

Isothermal end force at 100% Cu

p. 18

** $F_{1p} =$

Polytropic end force at 100% Cu

CODE	Cu	L	L min	F ₀		F _{1i} *		F _{1p} **		V ₀		Maintenance kit		PED 2014/68/EU
				Initial force	End force	End force	End force	cm ³	in ³	~Kg	~lb			
NCS 25 - 010 - A	10	75	65	300 ± 5%	674	452	1016	592	1331	5,7	0,35	0,17	0,37	✓
NCS 25 - 015 - A	15	85	70			490	1102	654	1470	7,3	0,45	0,19	0,42	✓
NCS 25 - 020 - A	20	95	75			518	1165	699	1571	9,0	0,55	0,20	0,44	✓
NCS 25 - 025 - A	25	105	80			539	1212	733	1648	10,6	0,65	0,21	0,46	✓
NCS 25 - 032 - A	32	120	88			551	1239	753	1693	13,2	0,81	0,23	0,51	✓
NCS 25 - 038 - A	38	135	97			542	1218	739	1661	16,0	0,98	0,25	0,55	✓
NCS 25 - 045 - A	45	150	105			551	1239	752	1691	18,6	1,13	0,27	0,60	✓
NCS 25 - 050 - A	50	160	110			560	1259	768	1727	20,2	1,23	0,28	0,62	✓
NCS 25 - 056 - A	56	175	119			552	1241	755	1697	23,0	1,40	0,30	0,66	✓
NCS 25 - 063 - A	63	190	127			557	1252	764	1718	25,6	1,56	0,32	0,71	✓
NCS 25 - 080 - A	80	225	145			573	1288	789	1774	31,4	1,92	0,37	0,82	✓

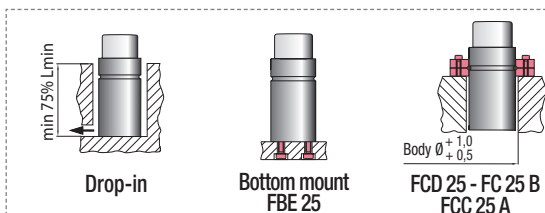

HOW TO ORDER

p. 31

INSTALLATION GUIDELINE

p. 75



SW

ACTIVE SAFETY



OSAS



USAS

* $F_{1i} =$

Isothermal end force at 100% Cu



p. 18

** $F_{1p} =$

Polytropic end force at 100% Cu



easu
MANIFOLD



p. 103

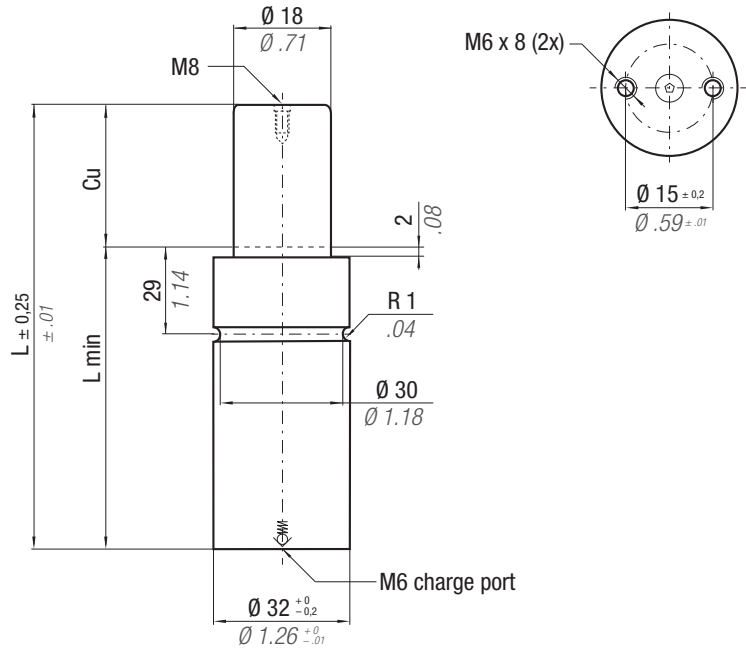

N₂

0 - 80 °C
32 - 176 °F

ΔP
± 0,33 %/°C

P max
197 bar
2857 psi

P min
20 bar
290 psi

S
2,54 cm²
0,394 in²

SPM
~ 20 - 100
(at 20°C)

Max Speed
1,8 m/s
70,8 in/s

Maintenance kit
Disposable

CODE	Cu		L		L min		F ₀		F _{1i} *		F _{1p} **		V ₀		PED		
	mm	inch	mm	inch	mm	inch	daN	lb	daN	lb	daN	lb	cm ³	in ³	~Kg	~lb	2014/68/EU
NCS 32 - 010 - A	10	0.39	75	2.95	65	2.56	500 1124 ± 5% 197 bar 2857 psi + 20°C +68°F		718	1614	928	2086	10,6	0.65	0,29	0.64	✓
NCS 32 - 015 - A	15	0.59	85	3.35	70	2.76			774	1740	1018	2289	13,4	0.82	0,31	0.68	✓
NCS 32 - 020 - A	20	0.79	95	3.74	75	2.95			815	1832	1083	2435	16,3	0.99	0,33	0.73	✓
NCS 32 - 025 - A	25	0.98	105	4.13	80	3.15			846	1902	1133	2547	19,2	1.17	0,34	0.75	✓
NCS 32 - 032 - A	32	1.26	120	4.72	88	3.46			866	1947	1165	2619	23,8	1.45	0,37	0.82	✓
NCS 32 - 038 - A	38	1.50	135	5.31	97	3.82			857	1927	1150	2585	28,7	1.75	0,40	0.88	✓
NCS 32 - 045 - A	45	1.77	150	5.91	105	4.13			870	1956	1171	2633	33,2	2.03	0,43	0.95	✓
NCS 32 - 050 - A	50	1.97	160	6.30	110	4.33			883	1985	1193	2682	36,1	2.20	0,45	0.99	✓
NCS 32 - 056 - A	56	2.20	175	6.89	119	4.69			874	1965	1179	2650	41,0	2.50	0,48	1.06	✓
NCS 32 - 063 - A	63	2.48	195	7.68	132	5.20			852	1915	1142	2567	48,0	2.93	0,52	1.15	✓
NCS 32 - 080 - A	80	3.15	230	9.06	150	5.91			878	1974	1184	2662	58,3	3.56	0,59	1.30	✓

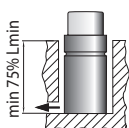

Drop-in

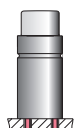

Bottom mount
FBE 32

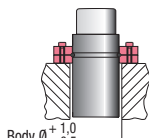

FCD 32 - FC 32
FCQC 32

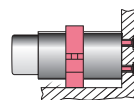

FSA 32 - FSD 32

HOW TO ORDER



p. 31

INSTALLATION GUIDELINE



p. 75

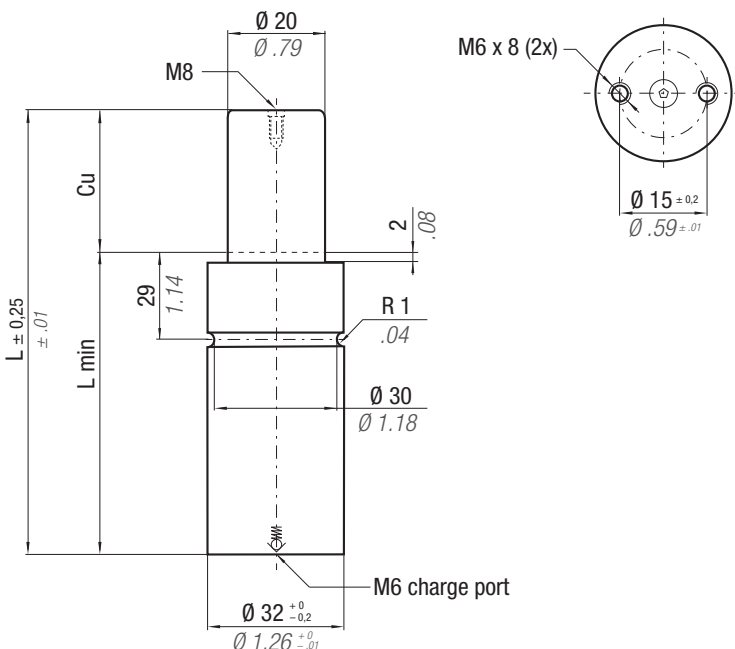

* $F_{1i} =$

Isothermal end force at 100% Cu



p. 18

** $F_{1p} =$

Polytropic end force at 100% Cu



easu
MANIFOLD



p. 103



SW

ACTIVE SAFETY



OSAS



USAS

NCS

CODE	N ₂	0 - 80 °C 32 - 176 °F	ΔP $\pm 0,33 \% / ^\circ C$	P max 210 bar 3045 psi	P min 20 bar 290 psi	S 3,14 cm ² 0.487 in ²	SPM ~ 20 - 100 (at 20°C)	Max Speed 1,8 m/s 70.8 in/s	Maintenance kit Disposable	Cu		L		L min		F ₀		F _{1i} *		F _{1p} **		V ₀		PED	
										mm	inch	mm	inch	mm	inch	daN	lb	daN	lb	daN	lb	cm ³	in ³	~Kg	~lb
NCS 32.2 - 010 - A										10	0.39	75	2.95	65	2.56	660 1484 $\pm 5\%$	993	2232	1282	2882	11,9	0.73	0,29	0.64	✓
NCS 32.2 - 015 - A									15	0.59	85	3.35	70	2.76	1087		2444	1428	3210	15,1	0.92	0,31	0.68	✓	
NCS 32.2 - 020 - A									20	0.79	95	3.74	75	2.95	1157		2601	1538	3458	18,3	1.12	0,32	0.71	✓	
NCS 32.2 - 025 - A									25	0.98	105	4.13	80	3.15	1212		2725	1624	3651	21,5	1.31	0,34	0.75	✓	
NCS 32.2 - 032 - A									32	1.26	120	4.72	88	3.46	1250		2810	1685	3788	26,4	1.61	0,37	0.82	✓	
NCS 32.2 - 038 - A									38	1.50	135	5.31	97	3.82	1240		2788	1669	3752	31,7	1.93	0,40	0.88	✓	
NCS 32.2 - 045 - A									45	1.77	150	5.91	105	4.13	1265		2844	1708	3840	36,6	2.23	0,43	0.95	✓	
NCS 32.2 - 050 - A									50	1.97	160	6.30	110	4.33	1289		2898	1747	3927	39,8	2.43	0,45	0.99	✓	
NCS 32.2 - 056 - A									56	2.20	175	6.89	119	4.69	1277		2871	1727	3882	45,1	2.75	0,48	1.06	✓	
NCS 32.2 - 063 - A									63	2.48	195	7.68	132	5.20	1242		2792	1671	3757	52,4	3.20	0,52	1.15	✓	
NCS 32.2 - 080 - A									80	3.15	230	9.06	150	5.91	1288	2896	1745	3923	63,7	3.89	0,59	1.30	✓		

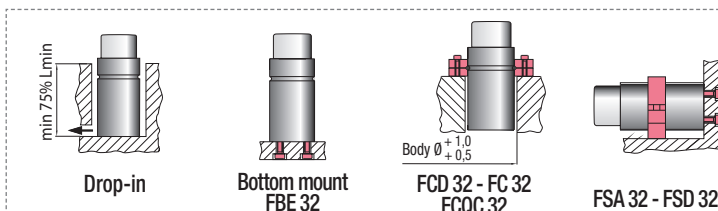

HOW TO ORDER

p. 31

INSTALLATION GUIDELINE

p. 75



SW

ACTIVE SAFETY



OSAS



USAS



OPAS

* $F_{1i} =$

Isothermal end force at 100% Cu



p. 18

** $F_{1p} =$

Polytropic end force at 100% Cu



easu
MANIFOLD



p. 103

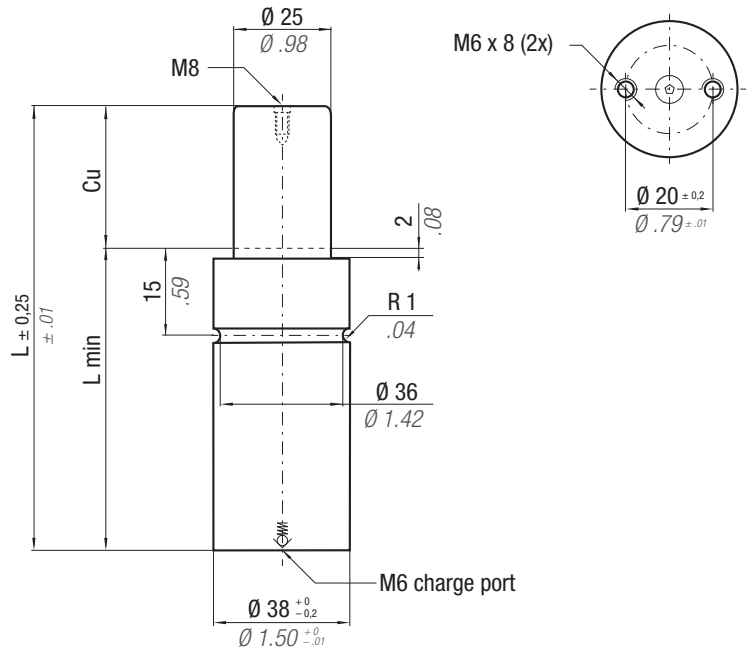

	0 - 80 °C 32 - 176 °F	ΔP ± 0,33 %/°C	P max 205 bar 2973 psi	P min 20 bar 290 psi	S 4,91 cm ² 0,761 in ²	SPM ~ 20 - 100 (at 20°C)	Max Speed 1,8 m/s 70,8 in/s	Maintenance kit 39BMMP01000A
--	--------------------------	---------------------------	-------------------------------------	-----------------------------------	---	---------------------------------------	--	--

CODE	Cu		L		L min		F ₀		F _{1i} *		F _{1p} **		V ₀		PED		
	mm	inch	mm	inch	mm	inch	daN	lb	daN	lb	daN	lb	cm ³	in ³	~Kg	~lb	2014/68/EU
NCS 38 - 010 - A	10	0.39	75	2.95	65	2.56	1000 ± 5% 205 bar 2973 psi + 20°C + 68°F		1414	3179	1810	4069	21,7	1.32	0,37	0.82	✓
NCS 38 - 015 - A	15	0.59	85	3.35	70	2.76			1543	3469	2009	4516	26,7	1.63	0,39	0.86	✓
NCS 38 - 020 - A	20	0.79	95	3.74	75	2.95			1644	3696	2168	4874	31,6	1.93	0,41	0.90	✓
NCS 38 - 025 - A	25	0.98	105	4.13	80	3.15			1725	3878	2296	5162	36,6	2.23	0,44	0.97	✓
NCS 38 - 032 - A	32	1.26	120	4.72	88	3.46			1793	4031	2404	5404	44,4	2.71	0,48	1.06	✓
NCS 38 - 038 - A	38	1.50	135	5.31	97	3.82			1795	4035	2407	5411	52,6	3.21	0,51	1.12	✓
NCS 38 - 045 - A	45	1.77	150	5.91	105	4.13			1838	4132	2476	5566	60,4	3.68	0,55	1.21	✓
NCS 38 - 050 - A	50	1.97	160	6.30	110	4.33			1875	4215	2537	5703	65,4	3.99	0,58	1.28	✓
NCS 38 - 056 - A	56	2.20	175	6.89	119	4.69			1867	4197	2524	5674	73,6	4.49	0,62	1.37	✓
NCS 38 - 063 - A	63	2.48	205	8.07	142	5.59			1723	3873	2293	5155	92,5	5.64	0,70	1.54	✓
NCS 38 - 080 - A	80	3.15	240	9.45	160	6.30	1801	4049	2417	5434	110,2	6.72	0,79	1.74	✓		

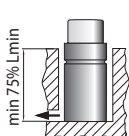

Drop-in



Bottom mount
FBE 38

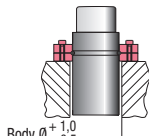

FCD 38 - FC 38
FCQC 38

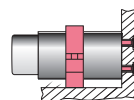

FSA 38 - FSD 38

HOW TO ORDER

p. 31

INSTALLATION GUIDELINE

p. 75

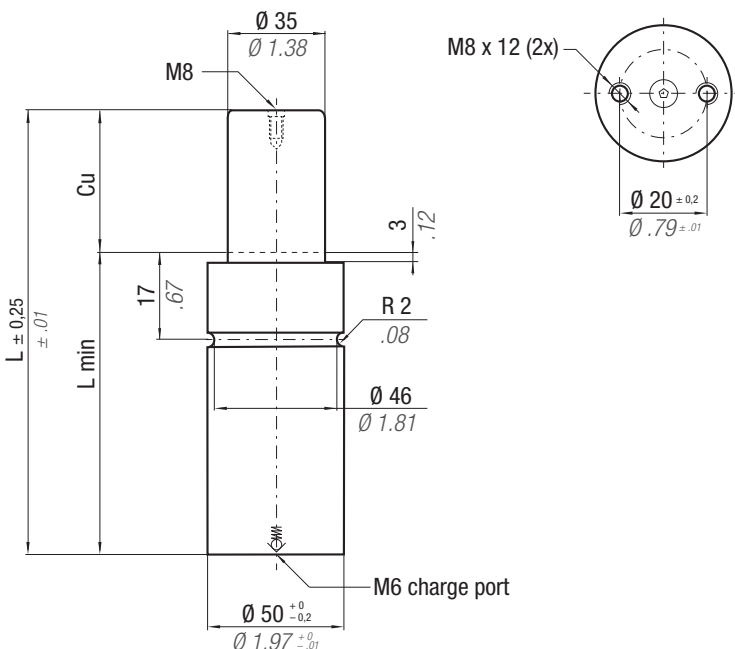

* $F_{1i} =$

Isothermal end force at 100% Cu



p. 18

** $F_{1p} =$

Polytrophic end force at 100% Cu



easu
MANIFOLD



p. 103



SW

ACTIVE SAFETY



OSAS



USAS



OPAS

NCS

	$0 - 80^{\circ}\text{C}$ $32 - 176^{\circ}\text{F}$	ΔP $\pm 0,33\% / ^{\circ}\text{C}$	P max 209 bar 3031 psi	P min 20 bar 290 psi	S 9,62 cm ² 1.491 in ²	SPM ~ 20 - 100 (at 20°C)	Max Speed 1,8 m/s 70.8 in/s	Maintenance kit 39BMMP02000A
--	--	---	-------------------------------------	-----------------------------------	---	---------------------------------------	--	--

CODE	Cu		L		L min		F ₀		F _{1i} *		F _{1p} **		V ₀		~Kg ~lb		PED 2014/68/EU
	mm	inch	mm	inch	mm	inch	daN	lb	daN	lb	daN	lb	cm ³	in ³			
NCS 50 - 010 - A	10	0.39	90	3.54	80	3.15	2000 4496 ± 5% 209 bar 3031 psi + 20°C +68°F		2639	5933	3326	7477	52,1	3.18	0,76	1.68	✓
NCS 50 - 015 - A	15	0.59	115	4.53	100	3.94			2622	5894	3301	7421	79,8	4.87	0,89	1.96	✓
NCS 50 - 020 - A	20	0.79	125	4.92	105	4.13			2782	6254	3541	7960	88,9	5.42	0,93	2.05	✓
NCS 50 - 025 - A	25	0.98	135	5.31	110	4.33			2926	6578	3759	8451	98,0	5.98	0,98	2.16	✓
NCS 50 - 032 - A	32	1.26	150	5.91	118	4.65			3086	6938	4004	9001	112,0	6.83	1,04	2.29	✓
NCS 50 - 038 - A	38	1.50	165	6.50	127	5.00			3166	7117	4127	9278	126,6	7.72	1,11	2.45	✓
NCS 50 - 045 - A	45	1.77	180	7.09	135	5.31			3283	7380	4310	9689	146,0	8.91	1,18	2.60	✓
NCS 50 - 050 - A	50	1.97	190	7.48	140	5.51			3370	7576	4446	9995	149,6	9.13	1,22	2.69	✓
NCS 50 - 056 - A	56	2.20	205	8.07	149	5.87			3414	7675	4514	10148	164,3	10.02	1,29	2.84	✓
NCS 50 - 063 - A	63	2.48	220	8.66	157	6.18			3497	7862	4646	10445	178,2	10.87	1,36	3.00	✓
NCS 50 - 080 - A	80	3.15	255	10.04	175	6.89	3688	8291	4948	11124	210,4	12.83	1,51	3.33	✓		

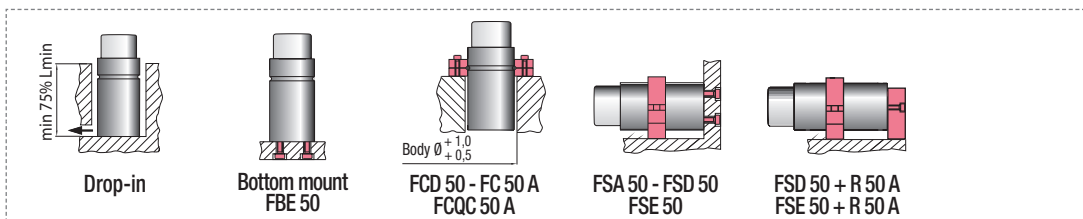

HOW TO ORDER

p. 31

INSTALLATION GUIDELINE

p. 75



SW

ACTIVE SAFETY



OSAS



USAS



OPAS

* $F_{1i} =$

Isothermal end force at 100% Cu



p. 18

** $F_{1p} =$

Polytrophic end force at 100% Cu



easu
MANIFOLD



p. 103

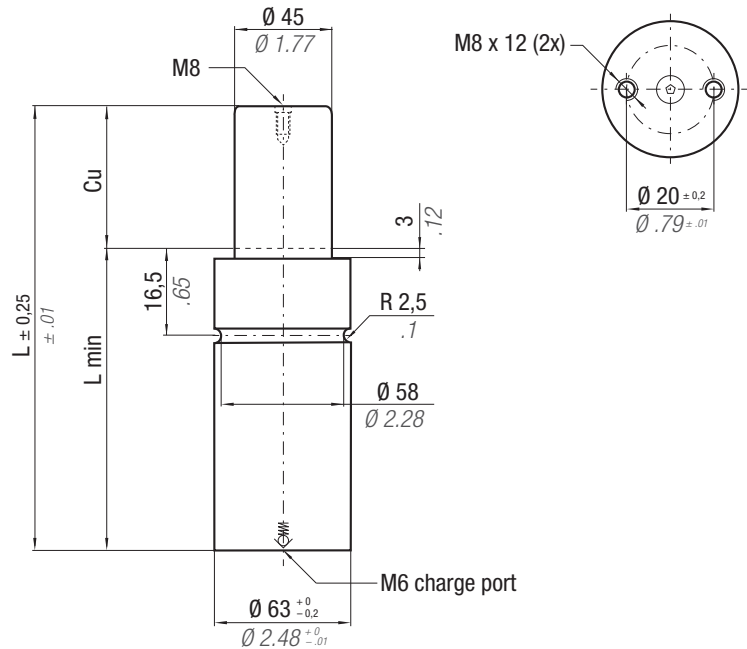

CODE	Cu	L	L min	F ₀ Initial force	F _{1i} *		F _{1p} **		V ₀		Maintenance kit			
					daN	lb	daN	lb	daN	lb	cm ³	in ³	~Kg	~lb
NCS 63 - 010 - A	10	95	85	3000 ± 5% 189 bar 2741 psi + 20°C +68°F	6744	3798	8538	4802	10795	95,5	5.83	1,25	2.76	✓
NCS 63 - 015 - A	15	115	100			3883	8729	4935	11094	131,9	8.05	1,40	3.09	✓
NCS 63 - 020 - A	20	125	105			4108	9235	5289	11890	147,3	8.99	1,46	3.22	✓
NCS 63 - 025 - A	25	135	110			4308	9685	5608	12607	162,6	9.92	1,52	3.35	✓
NCS 63 - 032 - A	32	150	118			4528	10179	5964	13408	186,2	11.36	1,62	3.57	✓
NCS 63 - 038 - A	38	165	127			4636	10422	6139	13801	210,9	12.86	1,72	3.79	✓
NCS 63 - 045 - A	45	180	135			4796	10782	6401	14390	234,5	14.30	1,82	4.01	✓
NCS 63 - 050 - A	50	190	140			4915	11049	6596	14828	249,9	15.24	1,89	4.17	✓
NCS 63 - 063 - A	63	220	157			5084	11429	6877	15460	298,2	18.19	2,08	4.59	✓
NCS 63 - 080 - A	80	255	175			5340	12005	7306	16425	352,5	21.50	2,31	5.09	✓

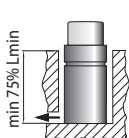

Drop-in



Bottom mount
FBE 63

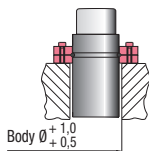

FCD 63 - FCQ 63 A
FCQC 63

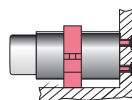

FSD 63 - FSD 63

HOW TO ORDER

p. 31

INSTALLATION GUIDELINE

p. 75

THIS PAGE IS INTENTIONALLY LEFT BLANK

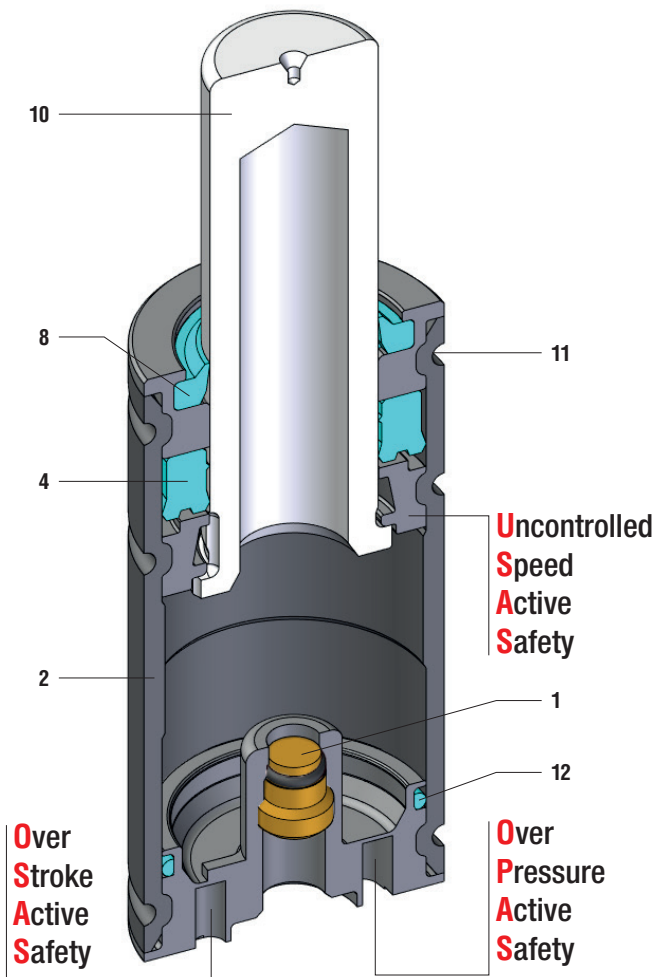

NML 25

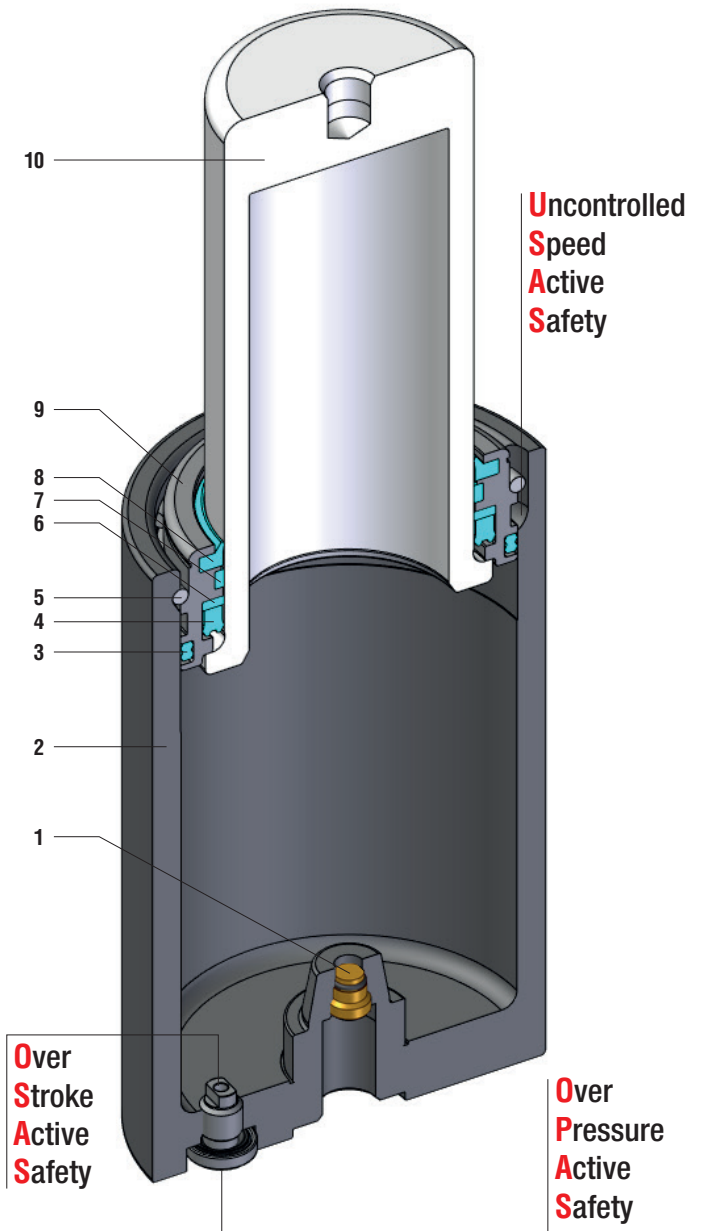

NML 32 ÷ NML 75

SEALING	ROD SEAL
DESIGN	BUSH - BODY DESIGN

1	Valve	5	Retaining ring	9	Bush
2	Body	6	Back-up ring	10	Rod (nitrited superfinished)
3	Dual ring seal	7	Guide ring	11	Groover for secondary wiper
4	Rod seal	8	Rod wiper	12	O-ring

RANGE CHART

Model	Body Ø		Stroke Cu		Initial force F0					
	mm	inch	mm	inch	daN	lb	OSAS	USAS	OPAS	SW
NML 25	25	0.98	5 - 125	0.20 - 4.92	300	674	✓	✓	✓	✓
NML 32	32	1.26	5 - 125	0.20 - 4.92	500	1124	✓	✓	✓	✓
NML 38	38	1.50	5 - 125	0.20 - 4.92	750	1686	✓	✓	✓	✓
NML 50	50	1.97	5 - 125	0.20 - 4.92	1500	3372	✓	✓	✓	✓
NML 63	63	2.48	5 - 125	0.20 - 4.92	2000	4496	✓	✓	✓	✓
NML 75	75	2.95	5 - 125	0.20 - 4.95	3000	6744	✓	✓	✓	✓

✓ Built-in as standard ✓ Optional upon request

NML

HOW TO ORDER

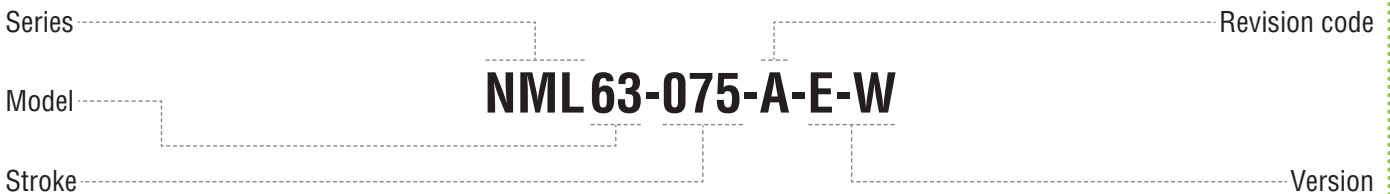

Available versions

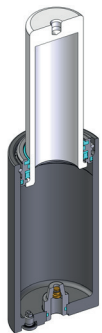

NML 63-075-A
Standard code



Self contained

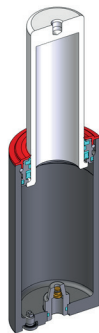

NML 63-075-A-W
Add "-W" to standard code



Self contained



+
Secondary wiper

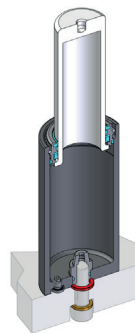

NML 63-075-A-E
Add "-E" to standard code



Easy
Manifold

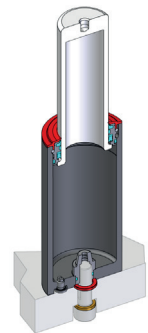

NML 63-075-A-E-W
Add "-E-W" to standard code



Easy
Manifold



+
Secondary wiper



SW

ACTIVE SAFETY



OSAS



USAS



OPAS

* $F_{1i} =$

Isothermal end force at 100% Cu



p. 18

** $F_{1p} =$

Polytropic end force at 100% Cu



easu
MANIFOLD



p. 103

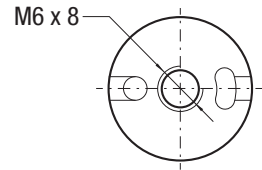
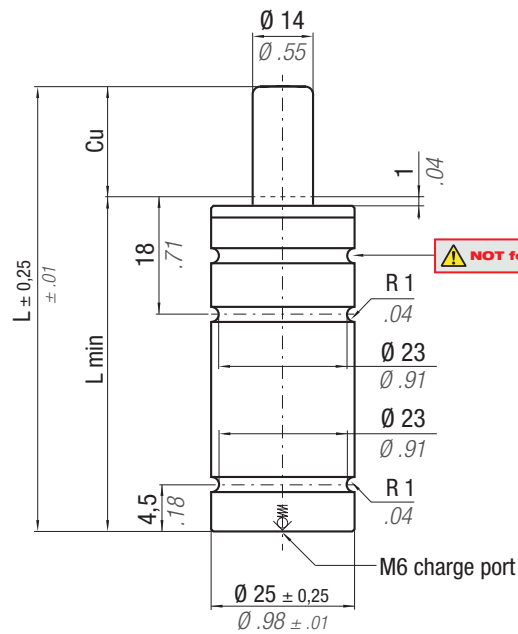

NOT for mounting



N₂

0 - 80 °C
32 - 176 °F

ΔP
± 0,33 %/°C

P max
195 bar
2828 psi

P min
20 bar
290 psi

S
1,54 cm²
0,239 in²

SPM
~ 20 - 100
(at 20°C)

Max Speed
1,8 m/s
70,8 in/s

Maintenance kit
Disposable

CODE	Cu		L		L min		F ₀		F _{1i} *		F _{1p} **		V ₀		PED		
	mm	inch	mm	inch	mm	inch	daN	lb	daN	lb	daN	lb	cm ³	in ³	~Kg	~lb	2014/68/EU
NML 25 - 005 - A	5	0.20	40	1.57	35	1.37	300 ± 5% 195 bar 2828 psi + 20°C +68°F	674	415	1200	534	2936	3,5	0.21	0,09	0.20	✓
NML 25 - 010 - A	10	0.39	50	1.97	40	1.57			453	1334	594	4080	5,7	0.35	0,10	0.22	✓
NML 25 - 013 - A	13	0.51	56	2.20	43	1.69			466	1379	614	4343	7,0	0.43	0,10	0.22	✓
NML 25 - 015 - A	15	0.59	60	2.36	45	1.77			472	1402	624	4278	7,8	0.48	0,11	0.24	✓
NML 25 - 020 - A	20	0.79	70	2.76	50	1.96			483	1443	642	4391	10,0	0.61	0,12	0.26	✓
NML 25 - 025 - A	25	0.98	80	3.15	55	2.16			491	1470	654	4465	12,2	0.73	0,12	0.26	✓
NML 25 - 032 - A	32	1.26	94	3.70	62	2.44			498	1496	665	4532	15,3	0.93	0,14	0.31	✓
NML 25 - 038 - A	38	1.50	106	4.17	68	2.67			502	1511	672	4570	17,9	1.09	0,15	0.33	✓
NML 25 - 050 - A	50	1.97	130	5.12	80	3.15			507	1532	681	4624	23,1	1.41	0,16	0.35	✓
NML 25 - 063 - A	63	2.48	156	6.14	93	3.66			511	1546	688	4660	28,8	1.76	0,19	0.42	✓
NML 25 - 075 - A	75	2.95	180	7.09	105	4.13			514	1555	692	4714	34,1	2.08	0,21	0.46	✓
NML 25 - 080 - A	80	3.15	190	7.48	110	4.33			515	1558	693	4690	36,2	2.21	0,21	0.46	✓
NML 25 - 100 - A	100	3.94	230	9.06	130	5.11			517	1567	697	4737	45,0	2.75	0,25	0.55	✓
NML 25 - 125 - A	125	4.92	280	11.02	155	6.10			519	1575	700	4750	55,9	3.41	0,29	0.64	✓

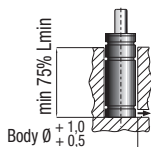

Drop-in

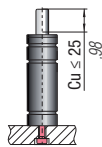

Bottom mount

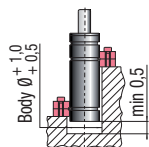

FC 25 B
FCC 25 A

HOW TO ORDER



p. 41

INSTALLATION GUIDELINE



p. 75



SW

ACTIVE SAFETY



OSAS



USAS



OPAS

NML

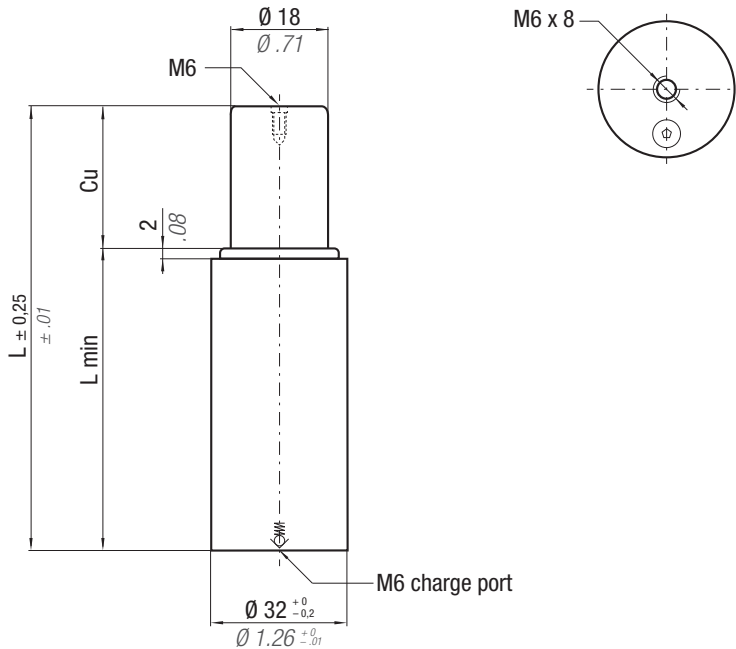

* $F_{1i} =$

Isothermal end force at 100% Cu



p. 18

** $F_{1p} =$

Polytropic end force at 100% Cu



p. 103

CODE	Cu	L	L min	F ₀		F _{1i} *		F _{1p} **		V ₀		Maintenance kit		
				Initial force	End force *	End force **	cm ³	in ³	~Kg	~lb				
	mm	inch	mm	inch	daN	lb	daN	lb	daN	lb	cm ³	in ³	~Kg	~lb
◆ NML 32 - 005 - A	5	0.20	40	1.57	500 1124 ± 5% 196 bar 2842 psi + 20°C +68°F	761	1711	999	2246	4,6	0.28	0,17	0,37	✓
NML 32 - 010 - A	10	0.39	50	1.97		851	1913	1143	2570	7,6	0.46	0,18	0,40	✓
NML 32 - 013 - A	13	0.51	56	2.20		872	1960	1179	2650	9,5	0.58	0,19	0,42	✓
NML 32 - 015 - A	15	0.59	60	2.36		883	1985	1196	2689	10,7	0.65	0,20	0,44	✓
NML 32 - 020 - A	20	0.79	70	2.76		902	2028	1227	2758	13,9	0.85	0,22	0,49	✓
NML 32 - 025 - A	25	0.98	80	3.15		914	2055	1247	2803	17,1	1.04	0,23	0,51	✓
NML 32 - 032 - A	32	1.26	94	3.70		925	2079	1265	2844	21,5	1.31	0,26	0,57	✓
NML 32 - 038 - A	38	1.50	106	4.17		931	2093	1276	2869	25,4	1.55	0,28	0,62	✓
NML 32 - 045 - A	45	1.77	120	4.72		937	2106	1285	2889	29,8	1.82	0,30	0,66	✓
NML 32 - 050 - A	50	1.97	130	5.12		940	2113	1290	2900	33,0	2.01	0,32	0,71	✓
NML 32 - 056 - A	56	2.20	142	5.59		943	2120	1295	2911	36,8	2.24	0,34	0,75	✓
NML 32 - 063 - A	63	2.48	156	6.14		946	2127	1299	2920	41,3	2.52	0,36	0,79	✓
NML 32 - 075 - A	75	2.95	180	7.09		949	2133	1306	2936	48,9	2.98	0,40	0,88	✓
NML 32 - 080 - A	80	3.15	190	7.48		950	2136	1308	2941	52,1	3.18	0,42	0,93	✓
NML 32 - 100 - A	100	3.94	230	9.06		954	2145	1314	2954	64,8	3.95	0,48	1,06	✓
NML 32 - 125 - A	125	4.92	280	11.02		957	2151	1319	2965	80,7	4.92	0,57	1,26	✓

◆ Disposable

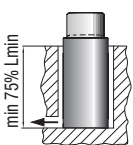

Drop-in



Bottom mount

HOW TO ORDER



p. 41

INSTALLATION GUIDELINE



p. 75



SW

ACTIVE SAFETY



OSAS



USAS



OPAS

* $F_{1i} =$

Isothermal end force at 100% Cu



p. 18

** $F_{1p} =$

Polytrophic end force at 100% Cu



easu
MANIFOLD



p. 103

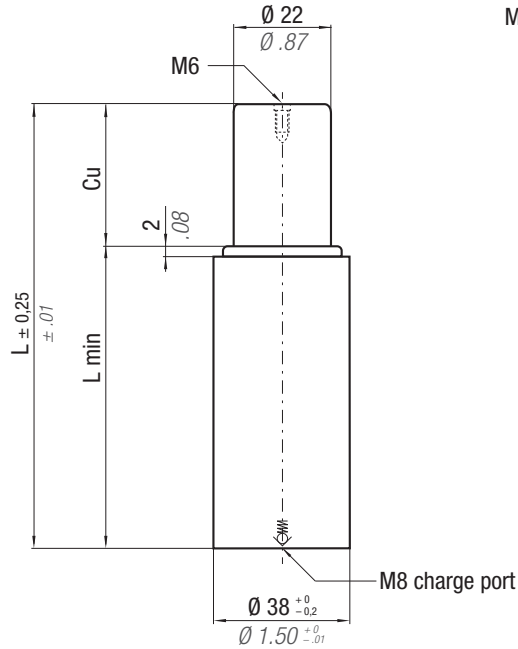

	0 - 80 °C 32 - 176 °F	ΔP ± 0,33 %/°C	P max 197 bar 2857 psi	P min 20 bar 290 psi	S 3,80 cm ² 0,589 in ²	SPM ~ 20 - 100 (at 20°C)	Max Speed 1,8 m/s 70.8 in/s	Maintenance kit 39BMGSN00038A
--	--------------------------	---------------------------	-------------------------------------	-----------------------------------	---	---------------------------------------	--	---

CODE	Cu		L		L min		F ₀		F _{1i} *		F _{1p} **		V ₀		PED		
	mm	inch	mm	inch	mm	inch	daN	lb	daN	lb	daN	lb	cm ³	in ³	~Kg	~lb	
◆ NML 38 - 005 - A	5	0.20	40	1.57	35	1.37	750 1686 ± 5% 197 bar 2857 psi + 20°C +68°F		1021	2295	1306	2936	9,0	0.55	0,22	0.49	✓
◆ NML 38 - 010 - A	10	0.39	50	1.97	40	1.57			1339	3010	1815	4080	10,6	0.65	0,27	0.60	✓
NML 38 - 013 - A	13	0.51	56	2.20	43	1.69			1410	3170	1932	4343	12,8	0.78	0,28	0.62	✓
NML 38 - 015 - A	15	0.59	60	2.36	45	1.77			1392	3129	1903	4278	15,1	0.92	0,29	0.64	✓
NML 38 - 020 - A	20	0.79	70	2.76	50	1.96			1422	3197	1953	4391	19,6	1.20	0,32	0.71	✓
NML 38 - 025 - A	25	0.98	80	3.15	55	2.16			1442	3242	1986	4465	24,0	1.46	0,34	0.75	✓
NML 38 - 032 - A	32	1.26	94	3.70	62	2.44			1460	3282	2016	4532	30,3	1.85	0,37	0.82	✓
NML 38 - 038 - A	38	1.50	106	4.17	68	2.67			1470	3305	2033	4570	35,7	2.18	0,40	0.88	✓
NML 38 - 045 - A	45	1.77	120	4.72	75	2.95			1479	3325	2049	4606	42,0	2.56	0,44	0.97	✓
NML 38 - 050 - A	50	1.97	130	5.12	80	3.15			1484	3336	2057	4624	46,5	2.84	0,46	1.01	✓
NML 38 - 056 - A	56	2.20	142	5.59	86	3.38			1489	3347	2065	4642	51,9	3.17	0,49	1.08	✓
NML 38 - 063 - A	63	2.48	156	6.14	93	3.66			1494	3359	2073	4660	58,2	3.55	0,52	1.15	✓
NML 38 - 075 - A	75	2.95	180	7.09	105	4.13			1508	3390	2097	4714	68,6	4.18	0,58	1.29	✓
NML 38 - 080 - A	80	3.15	190	7.48	110	4.33			1502	3377	2086	4690	73,5	4.48	0,60	1.32	✓
NML 38 - 100 - A	100	3.94	230	9.06	130	5.11			1514	3404	2107	4737	91,1	5.56	0,70	1.54	✓
NML 38 - 125 - A	125	4.92	280	11.02	155	6.10			1518	3413	2113	4750	113,5	6.92	0,82	1.81	✓

◆ Disposable

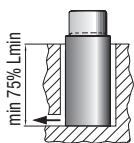

Drop-in



Bottom mount

HOW TO ORDER

p. 41

INSTALLATION GUIDELINE

p. 75



ACTIVE SAFETY

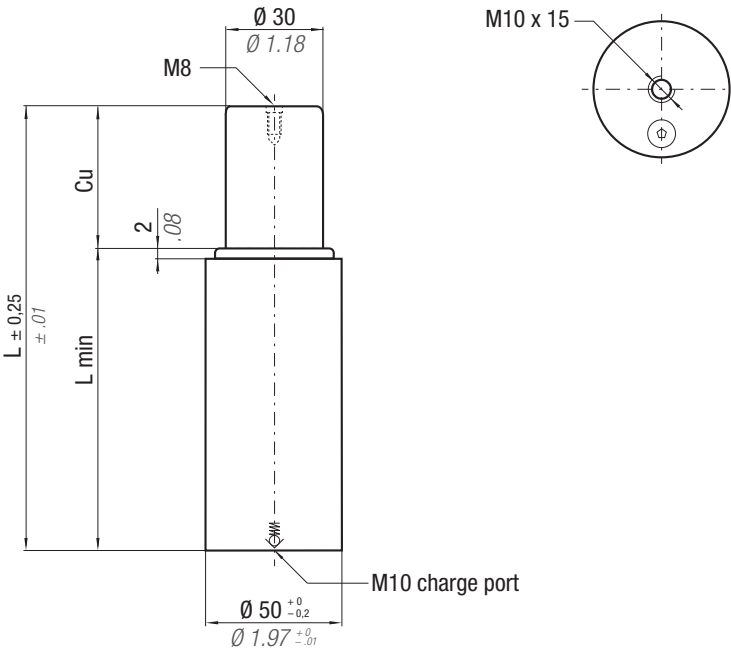

* F_{1i} =

Isothermal end force at 100% Cu

p. 18

** F_{1p} =

Polytropic end force at 100% Cu

p. 103



NML

CODE	Cu	L	L min	F ₀	S		SPM		Max Speed		Maintenance kit	
					daN	lb	~ 20 - 100 (at 20°C)	1,8 m/s 70.8 in/s	39BMNML00050A			
◆ NML 50 - 005 - A	5	45	40	1500 3372 ± 5%	2058	4627	2611	5870	16,7	1.02	0,44	0,97
◆ NML 50 - 010 - A	10	55	45		2607	5861	3451	7758	20,9	1.27	0,50	1.10
NML 50 - 013 - A	13	61	48		2677	6018	3561	8005	26,1	1.59	0,53	1.17
NML 50 - 015 - A	15	65	50		2712	6097	3615	8127	29,6	1.81	0,54	1.19
NML 50 - 020 - A	20	75	55		2771	6229	3709	8338	38,4	2.34	0,58	1.28
NML 50 - 025 - A	25	85	60		2810	6317	3770	8475	47,2	2.88	0,61	1.34
NML 50 - 032 - A	32	99	67		2846	6398	3827	8603	59,4	3.62	0,66	1.46
NML 50 - 038 - A	38	111	73		2867	6445	3861	8680	69,9	4.26	0,71	1.57
NML 50 - 045 - A	45	125	80		2885	6486	3890	8745	82,2	5.01	0,76	1.68
NML 50 - 050 - A	50	135	85		2895	6508	3905	8779	91,0	5.55	0,79	1.74
NML 50 - 056 - A	56	147	91		2905	6531	3921	8815	101,5	6.19	0,84	1.85
NML 50 - 063 - A	63	161	98		2914	6551	3936	8848	113,7	6.94	0,88	1.94
NML 50 - 075 - A	75	185	110		2926	6578	3955	8891	134,8	8.22	0,97	2.14
NML 50 - 080 - A	80	200	120		2868	6448	3861	8680	147,2	8.98	1,06	2.34
NML 50 - 100 - A	100	235	135		2942	6614	3980	8947	178,6	10.89	1,15	2.54
NML 50 - 125 - A	125	285	160		2952	6636	3995	8981	222,4	13.57	1,33	2.93

◆ Disposable

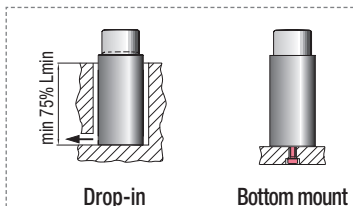

HOW TO ORDER

p. 41

INSTALLATION GUIDELINE

p. 75



SW

ACTIVE SAFETY



OSAS



USAS



OPAS

* $F_{1i} =$

Isothermal end force at 100% Cu



p. 18

** $F_{1p} =$

Polytropic end force at 100% Cu



easu
MANIFOLD



p. 103

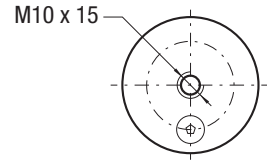
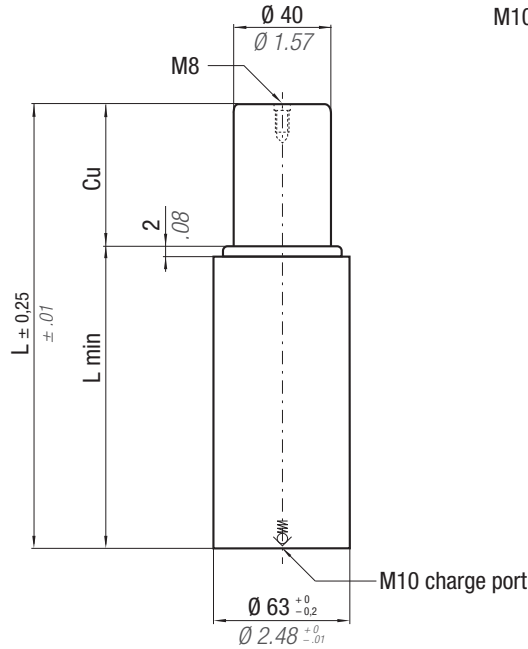

CODE	Cu	L	L min	F ₀ Initial force	F _{1i} *		F _{1p} **		V ₀		Maintenance kit		
					daN	lb	daN	lb	daN	lb	cm ³	in ³	~Kg
◆ NML 63 - 005 - A	5	45	40	2000 4496 ± 5% 159 bar 2306 psi + 20°C +68°F	2619	5888	3407	7659	31,4	1,92	0,69	1,52	✓
◆ NML 63 - 010 - A	10	55	45		2919	6562	3924	8822	46,8	2,85	0,75	1,65	✓
NML 63 - 015 - A	15	65	50		3163	7111	4357	9795	59,7	3,64	0,81	1,79	✓
NML 63 - 020 - A	20	75	55		3272	7356	4555	10240	75,1	4,58	0,86	1,90	✓
NML 63 - 025 - A	25	85	60		3349	7529	4694	10553	90,5	5,52	0,91	2,01	✓
NML 63 - 032 - A	32	99	67		3424	7697	4831	10861	112,1	6,84	0,99	2,18	✓
NML 63 - 038 - A	38	111	73		3469	7799	4916	11052	130,5	7,96	1,05	2,31	✓
NML 63 - 050 - A	50	135	85		3533	7942	5033	11315	167,5	10,22	1,17	2,58	✓
NML 63 - 063 - A	63	161	98		3577	8041	5115	11499	207,5	12,66	1,30	2,87	✓
NML 63 - 075 - A	75	185	110		3605	8104	5168	11618	244,4	14,91	1,42	3,13	✓
NML 63 - 080 - A	80	200	120		3662	8233	5275	11859	255,4	15,58	1,54	3,40	✓
NML 63 - 100 - A	100	235	135		3644	8192	5241	11782	321,3	19,60	1,68	3,70	✓
NML 63 - 125 - A	125	285	160		3669	8248	5287	11886	398,3	24,30	1,93	4,25	✓

◆ Disposable

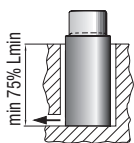

Drop-in



Bottom mount

HOW TO ORDER



p. 41

INSTALLATION GUIDELINE



p. 75



SW

ACTIVE SAFETY



OSAS



USAS



OPAS

NML

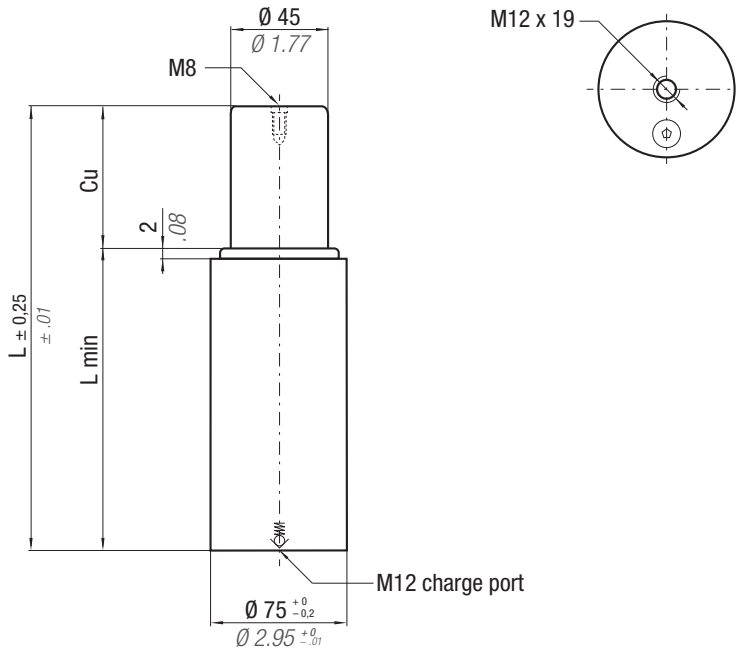

* $F_{1i} =$

Isothermal end force at 100% Cu



p. 18

** $F_{1p} =$

Polytropic end force at 100% Cu



easu
MANIFOLD



p. 103

CODE	N ₂	0 - 80 °C 32 - 176 °F	ΔP ± 0,33 %/°C	P max 189 bar 2741 psi	P min 20 bar 290 psi	S 15,90 cm ² 2,465 in ²	SPM ~ 20 - 100 (at 20°C)	Max Speed 1,8 m/s 70.8 in/s	Maintenance kit 39BMNML00075A	Cu		L		L min		F ₀		F _{1i} *		F _{1p} **		V ₀		PED	
										mm	inch	mm	inch	mm	inch	daN	lb	daN	lb	daN	lb	cm ³	in ³	~Kg	~lb
◆ NML 75 - 005 - A										5	0.20	50	1.77	45	1.77	3000 6744 ± 5% 189 bar 2741 psi + 20°C +68°F	3714	8349	4671	10501	52,4	3.20	1,07	2.36	✓
◆ NML 75 - 010 - A										10	0.39	60	2.17	50	1.96		4209	9462	5450	12252	68,9	4.20	1,17	2.58	✓
NML 75 - 015 - A										15	0.59	70	2.56	55	2.16		4739	10654	6306	14176	79,9	4.87	1,33	2.93	✓
NML 75 - 020 - A										20	0.79	80	2.95	60	2.36		4916	11052	6597	14831	99,9	6.09	1,41	3.11	✓
NML 75 - 025 - A										25	0.98	90	3.35	65	2.56		5040	11330	6803	15294	120,0	7.32	1,49	3.28	✓
NML 75 - 032 - A										32	1.26	104	3.90	72	2.83		5163	11607	7008	15755	148,0	9.03	1,60	3.53	✓
NML 75 - 038 - A										38	1.50	115	4.37	77	3.03		5276	11861	7197	16179	170,3	10.39	1,67	3.68	✓
NML 75 - 050 - A										50	1.97	140	5.31	90	3.54		5344	12014	7313	16440	220,1	13.43	1,88	4.14	✓
NML 75 - 063 - A										63	2.48	166	6.34	103	4.05		5419	12182	7438	16721	272,2	16.60	2,09	4.61	✓
NML 75 - 075 - A										75	2.95	190	7.28	115	4.52		5467	12290	7520	16906	320,2	19.53	2,27	5.00	✓
NML 75 - 080 - A										80	3.15	205	7.87	126	4.96		5336	11996	7298	16407	352,9	21.53	2,43	5.36	✓
NML 75 - 100 - A										100	3.94	245	9.25	145	5.70		5409	12160	7422	16685	433,0	26.41	2,74	6.04	✓
NML 75 - 125 - A										125	4.92	295	11.22	170	6.69		5471	12299	7527	16921	533,2	32.53	3,13	6.90	✓

◆ Disposable

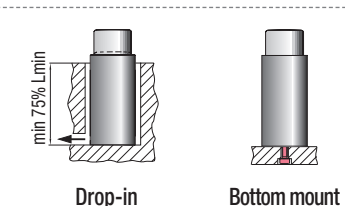

HOW TO ORDER



p. 41

INSTALLATION GUIDELINE



p. 75

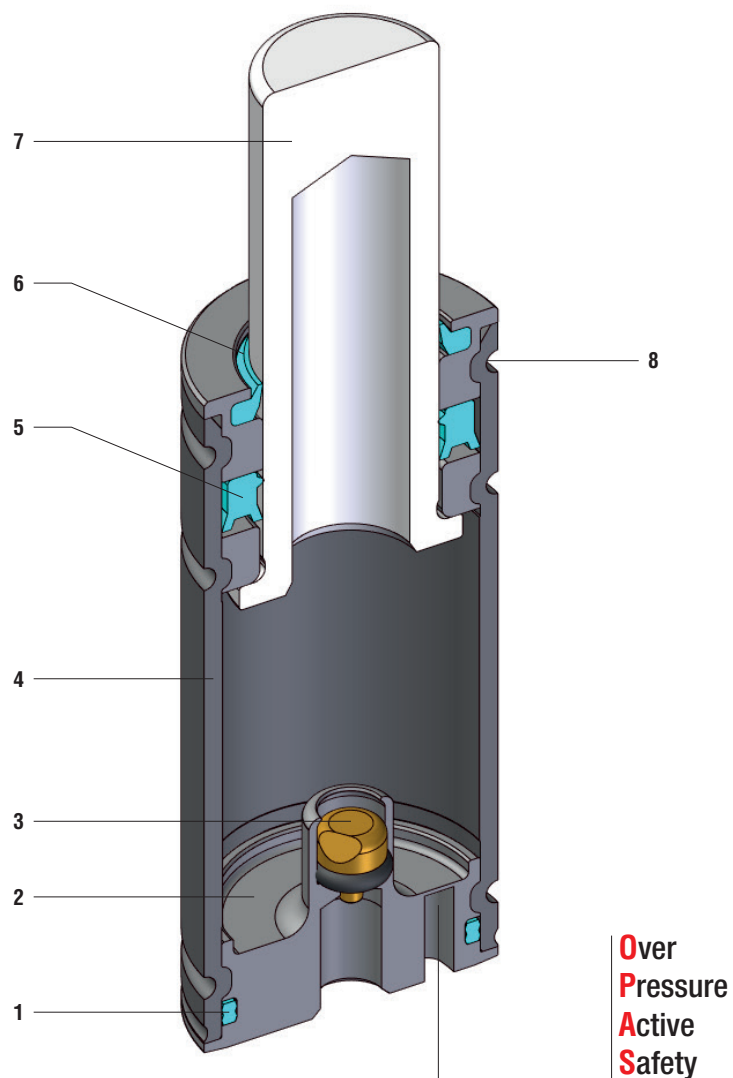

SEALING	ROD SEAL
DESIGN	RETAINING GROOVE DESIGN

1	Dual ring seal	4	Body	7	Rod (nitrited superfinished)
2	Bottom base	5	Rod seal	8	Groove for secondary wiper
3	Valve	6	Rod wiper		

RANGE CHART

Model	Body Ø		Stroke Cu		Initial force F0					
	mm	inch	mm	inch	daN	lb	OSAS	USAS	OPAS	SW
NMS 16	16	0.63	10 - 50	0.39 - 1.97	100	225	-	-	-	-
NMS 19	19	0.75	10 - 50	0.39 - 1.97	170	382	-	-	✓	✓
NMS 25	25	0.98	10 - 50	0.39 - 1.97	360	809	-	-	✓	✓

Built-in as standard
 Optional upon request

NMS

HOW TO ORDER

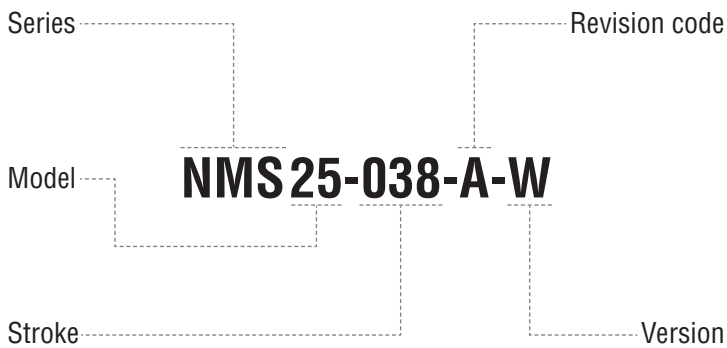

Available versions

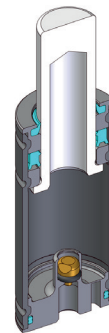

NMS 25-038-A
Standard code



Self contained

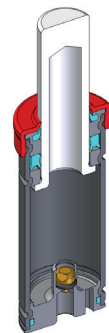

NMS 25-038-A-W
Add "-W" to standard code



Self contained



+
Secondary wiper

ACTIVE SAFETY

* $F_{1i} =$

Isothermal end force at 100% Cu p. 18

** $F_{1p} =$

Polytropic end force at 100% Cu

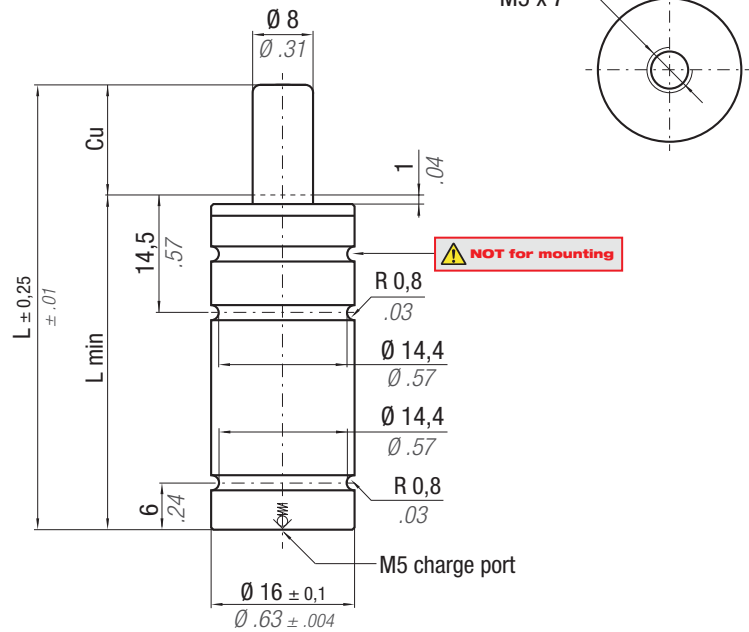

	0 - 80 °C 32 - 176 °F	ΔP ± 0,33 %/°C	P max 200 bar 2900 psi	P min 20 bar 290 psi	S 0,50 cm ² 0,078 in ²	SPM ~ 20 - 100 (at 20°C)	Max Speed 1,8 m/s 70.8 in/s	Maintenance kit Disposable
CODE	Cu	L	L min	F ₀ Initial force	F _{1i} * End force *	F _{1p} ** End force **	V ₀	
	mm inch	mm inch	mm inch	daN lb	daN lb	daN lb	cm ³ in ³	~Kg ~lb
NMS 16 - 010 - A	10 0.39	55 2.17	45 1.77	100 225 ± 5% 200 bar 2900 psi + 20°C +68°F	140 315	179 402	2,3 0.14	0,05 0.11
NMS 16 - 015 - A	15 0.59	65 2.56	50 1.97		148 333	193 434	2,9 0.18	0,05 0.12
NMS 16 - 020 - A	20 0.79	75 2.95	55 2.17		154 346	202 454	3,6 0.22	0,06 0.13
NMS 16 - 025 - A	25 0.98	85 3.35	60 2.36		159 357	209 470	4,3 0.26	0,06 0.14
NMS 16 - 032 - A	32 1.26	99 3.90	67 2.64		163 366	216 486	5,2 0.32	0,07 0.15
NMS 16 - 038 - A	38 1.50	111 4.37	73 2.87		166 373	221 497	6,0 0.37	0,08 0.17
NMS 16 - 045 - A	45 1.77	125 4.92	80 3.15		169 380	225 506	6,9 0.42	0,08 0.18
NMS 16 - 050 - A	50 1.97	135 5.31	85 3.35		170 382	228 513	7,6 0.46	0,08 0.19

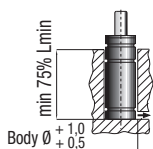

Drop-in

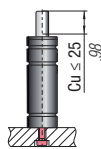

Bottom mount

HOW TO ORDER

p. 49

INSTALLATION GUIDELINE

p. 75



ACTIVE SAFETY



OPAS

* $F_{1i} =$

Isothermal end force at 100% Cu

p. 18

** $F_{1p} =$

Polytropic end force at 100% Cu

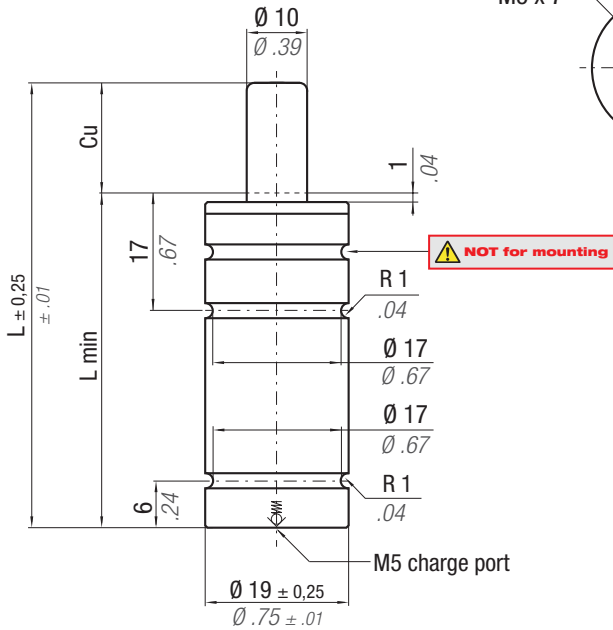
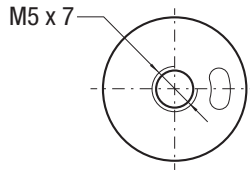

CODE	Cu	L	L min	F ₀ Initial force	* F _{1i}		** F _{1p}		V ₀		Maintenance kit		
					daN	lb	daN	lb	daN	lb	cm ³	in ³	~Kg
NMS 19 - 010 - A	10	55	45	170 382 ± 5% 216 bar 3132 psi +20°C +68°F	238	535	302	679	3,5	0,21	0,06	0,14	✓
NMS 19 - 015 - A	15	65	50		251	564	322	724	4,7	0,29	0,07	0,15	✓
NMS 19 - 020 - A	20	75	55		260	585	335	753	5,8	0,35	0,08	0,17	✓
NMS 19 - 025 - A	25	85	60		266	598	344	773	6,9	0,42	0,08	0,18	✓
NMS 19 - 032 - A	32	99	67		272	611	354	796	8,5	0,52	0,09	0,19	✓
NMS 19 - 038 - A	38	111	73		276	620	360	809	9,8	0,60	0,09	0,21	✓
NMS 19 - 045 - A	45	125	80		279	627	365	821	11,4	0,70	0,10	0,22	✓
NMS 19 - 050 - A	50	135	85		281	632	368	827	12,6	0,77	0,11	0,24	✓

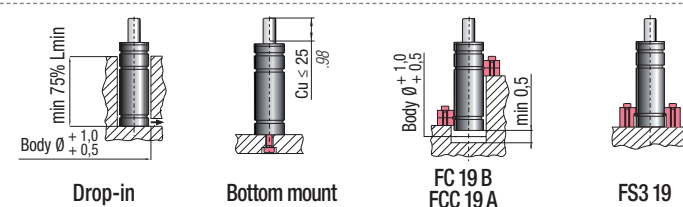

HOW TO ORDER

p. 49

INSTALLATION GUIDELINE

p. 75



ACTIVE SAFETY



* $F_{1i} =$

Isothermal end force at 100% Cu p. 18

** $F_{1p} =$

Polytropic end force at 100% Cu

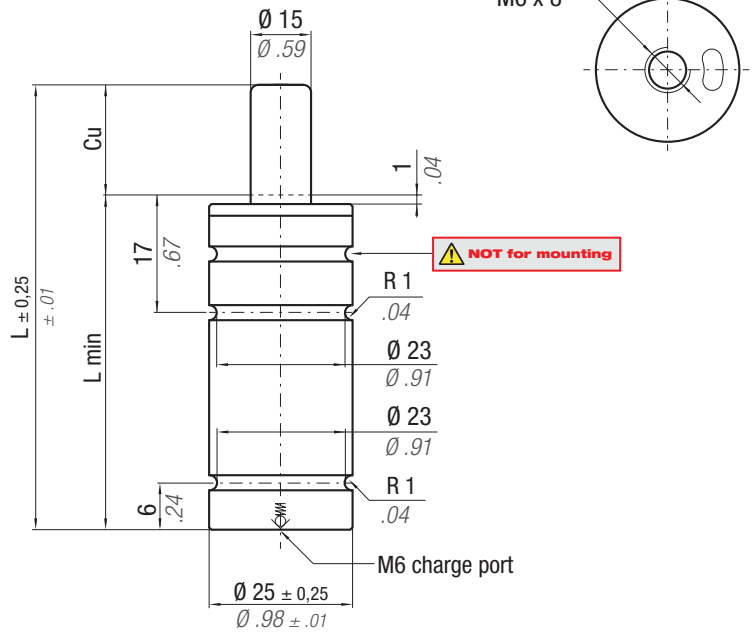

CODE	Cu	L	L min	F ₀ Initial force	F _{1i} *		F _{1p} **		V ₀		Maintenance kit		
					daN	lb	daN	lb	daN	lb	cm ³	in ³	~Kg
NMS 25 - 010 - A	10	55	45	360 809 ± 5% 204 bar 2958 psi + 20°C +68°F	516	1160	663	1490	7,4	0,45	0,11	0,24	✓
NMS 25 - 015 - A	15	65	50		549	1234	715	1607	9,7	0,59	0,12	0,26	✓
NMS 25 - 020 - A	20	75	55		572	1286	751	1688	12,0	0,73	0,13	0,28	✓
NMS 25 - 025 - A	25	85	60		588	1322	777	1747	14,2	0,87	0,13	0,29	✓
NMS 25 - 032 - A	32	99	67		605	1360	803	1805	17,4	1,06	0,15	0,32	✓
NMS 25 - 038 - A	38	111	73		616	1385	820	1843	20,1	1,23	0,16	0,34	✓
NMS 25 - 045 - A	45	125	80		625	1405	835	1877	23,3	1,42	0,17	0,37	✓
NMS 25 - 050 - A	50	135	85		631	1419	844	1897	25,6	1,56	0,18	0,39	✓

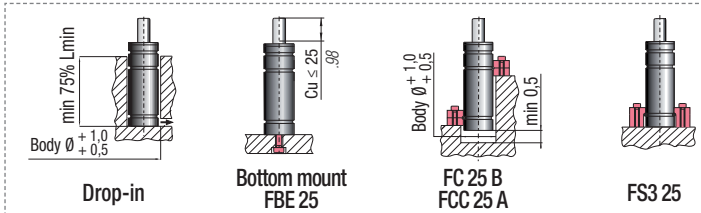

HOW TO ORDER
 p. 49

INSTALLATION GUIDELINE
 p. 75



THIS PAGE IS INTENTIONALLY LEFT BLANK

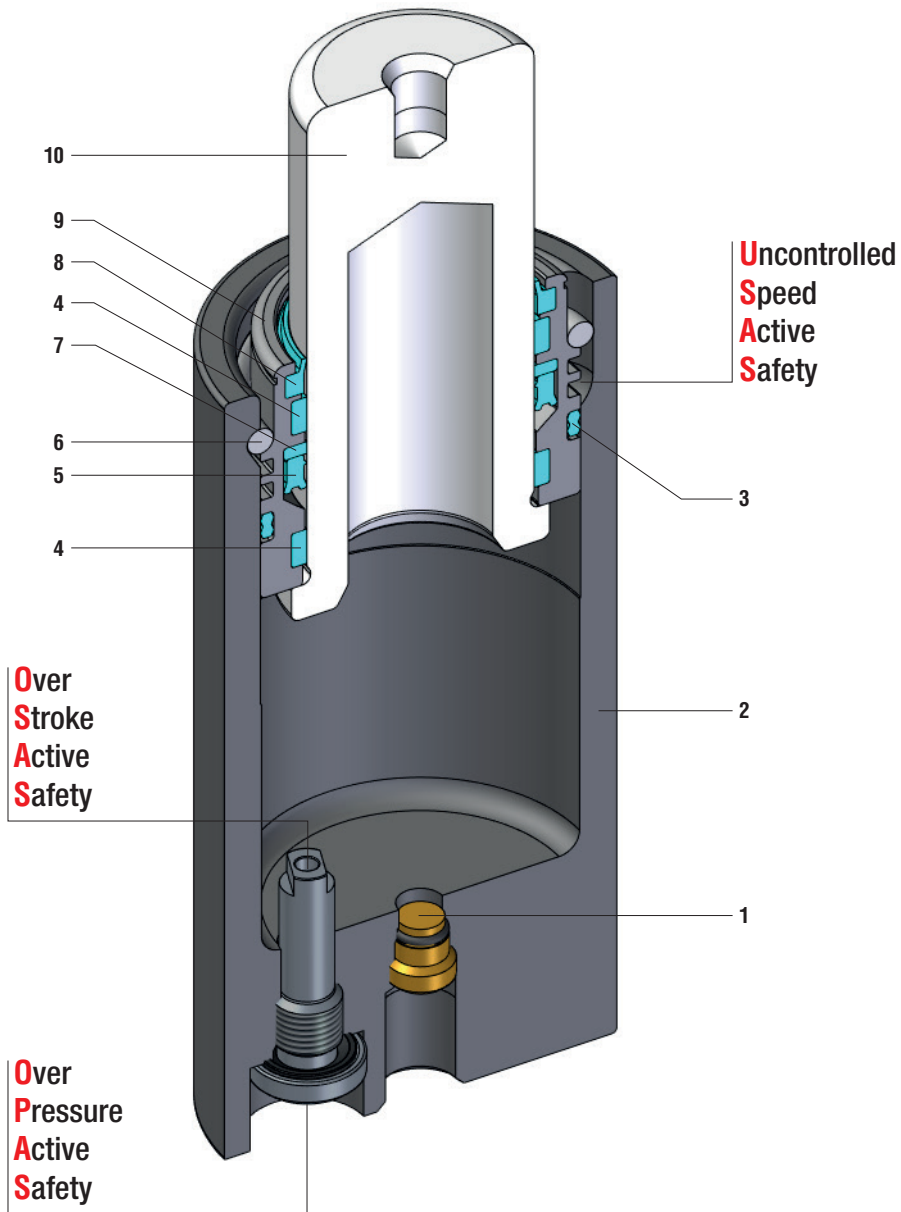

SEALING	ROD SEAL
DESIGN	BUSH - BODY DESIGN

1	Valve	5	Rod seal	9	Bush
2	Body	6	Retaining ring	10	Rod (nitrited superfinished)
3	Dual ring seal	7	Back-up ring		
4	Guide ring	8	Rod wiper		

RANGE CHART

Model	Body Ø		Stroke Cu		Initial force F0		OSAS	USAS	OPAS	SW
	mm	inch	mm	inch	daN	lb				
NC 32	32	1.26	10 - 80	0.39 - 3.15	500	1124	✓	✓	✓	✓
NC 38	38	1.50	10 - 80	0.39 - 3.15	750	1686	✓	✓	✓	✓

✓ Built-in as standard
✓ Optional upon request

NC

HOW TO ORDER

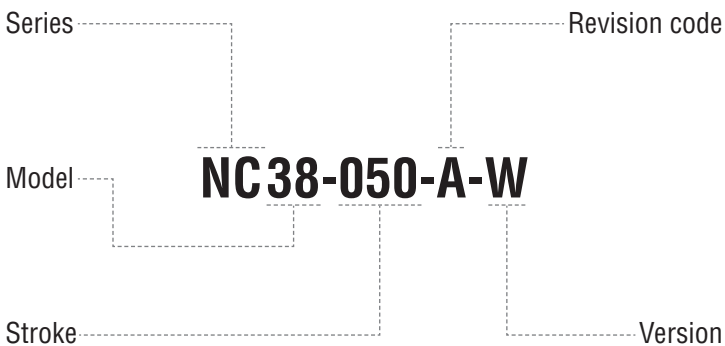

Available versions

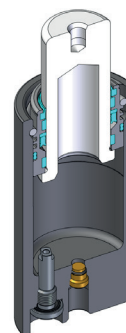

NC 38-050-A
Standard code



Self contained

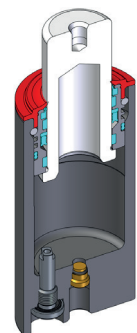

NC 38-050-A-W
Add "-W" to standard code



Self contained



+
Secondary wiper



SW

ACTIVE SAFETY



OSAS



USAS



OPAS

* $F_{1i} =$

Isothermal end force at 100% Cu p. 18

** $F_{1p} =$

Polytrophic end force at 100% Cu

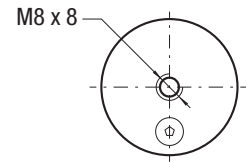
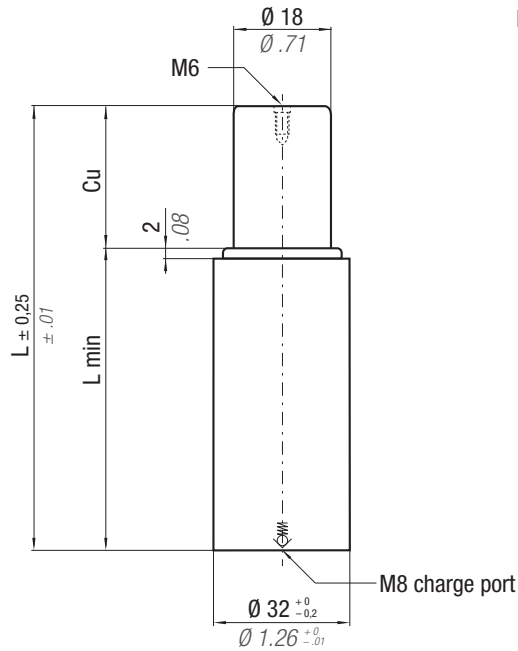

CODE		Cu		L		L min		F ₀		F _{1i} *		F _{1p} **		V ₀		Maintenance kit		
		mm	inch	mm	inch	mm	inch	daN	lb	daN	lb	daN	lb	cm ³	in ³	~Kg	~lb	
◆ NC 32 - 010 - A		10	0.40	70	2.76	60	2.36	500 1124 ± 5% 196 bar 2842 psi + 20°C + 68°F		710	1596	918	2064	10,7	0.65	0,28	0.62	39BMNC00032A
NC 32 - 015 - A		15	0.59	80	3.15	65	2.56			758	1704	994	2235	13,9	0.85	0,30	0.66	✓
NC 32 - 025 - A		25	0.99	100	3.94	75	2.95			815	1832	1085	2439	20,2	1.23	0,33	0.73	✓
NC 32 - 038 - A		38	1.50	126	4.96	88	3.46			855	1922	1150	2585	28,5	1.74	0,38	0.83	✓
NC 32 - 050 - A		50	1.97	150	5.91	100	3.93			877	1972	1187	2668	36,1	2.20	0,41	0.91	✓
NC 32 - 080 - A		80	3.15	210	8.27	130	5.11			907	2039	1236	2779	55,2	3.37	0,51	1.13	✓

◆ Disposable

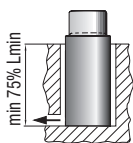

Drop-in



Bottom mount

HOW TO ORDER

p. 55

INSTALLATION GUIDELINE

p. 75



ACTIVE SAFETY

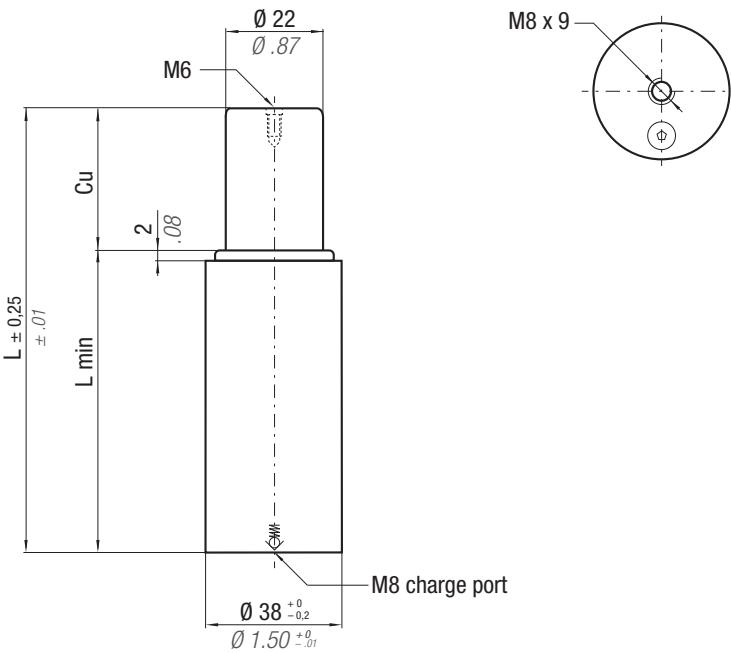

* $F_{1i} =$

Isothermal end force at 100% Cu



p. 18



** $F_{1p} =$

Polytropic end force at 100% Cu

CODE	N ₂	0 - 80 °C 32 - 176 °F	ΔP ± 0,33 %/°C	P max 197 bar 2857 psi	P min 20 bar 290 psi	S 3,80 cm ² 0.589 in ²	SPM ~ 20 - 100 (at 20°C)	Max Speed 1,8 m/s 70.8 in/s	Maintenance kit 39BMNC00038A	Cu		L		L min		F ₀		F _{1i} *		F _{1p} **		V ₀		~Kg ~lb		PED 2014/68/EU
										mm	inch	mm	inch	mm	inch	daN	lb	daN	lb	daN	lb	cm ³	in ³			
◆ NC 38 - 010 - A										10	0.40	75	2.95	65	2.56	750 1686 ± 5% 197 bar 2857 psi + 20°C +68°F	1029	2313	1319	2965	17,6	1.07	0,42	0.93	✓	
NC 38 - 015 - A										15	0.59	85	3.35	70	2.75		1106	2486	1439	3235	22,1	1.35	0,44	0.98	✓	
NC 38 - 025 - A										25	0.99	105	4.13	80	3.15		1205	2709	1598	3592	31,1	1.90	0,49	1.08	✓	
NC 38 - 038 - A										38	1.50	131	5.16	93	3.66		1282	2882	1721	3869	42,7	2.60	0,56	1.22	✓	
NC 38 - 050 - A										50	1.97	155	6.10	105	4.13		1326	2981	1794	4033	53,5	3.26	0,61	1.35	✓	
NC 38 - 080 - A										80	3.15	220	8.66	140	5.51		1363	3064	1854	4168	82,5	5.03	0,79	1.73	✓	

◆ Disposable

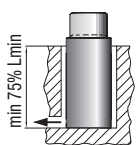

Drop-in



Bottom mount

HOW TO ORDER



p. 55

INSTALLATION GUIDELINE



p. 75

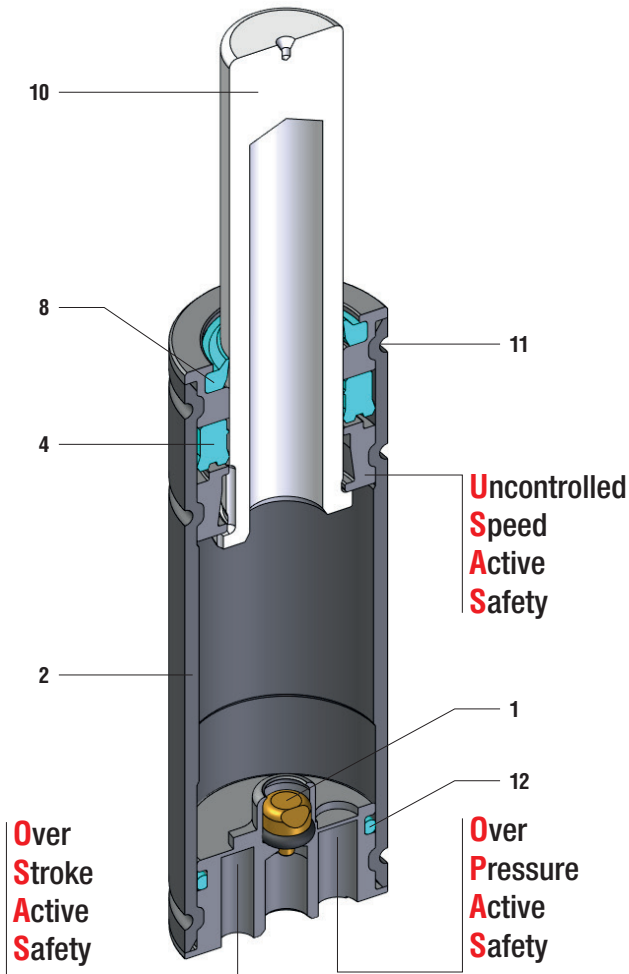

NMX 19 ÷ 25

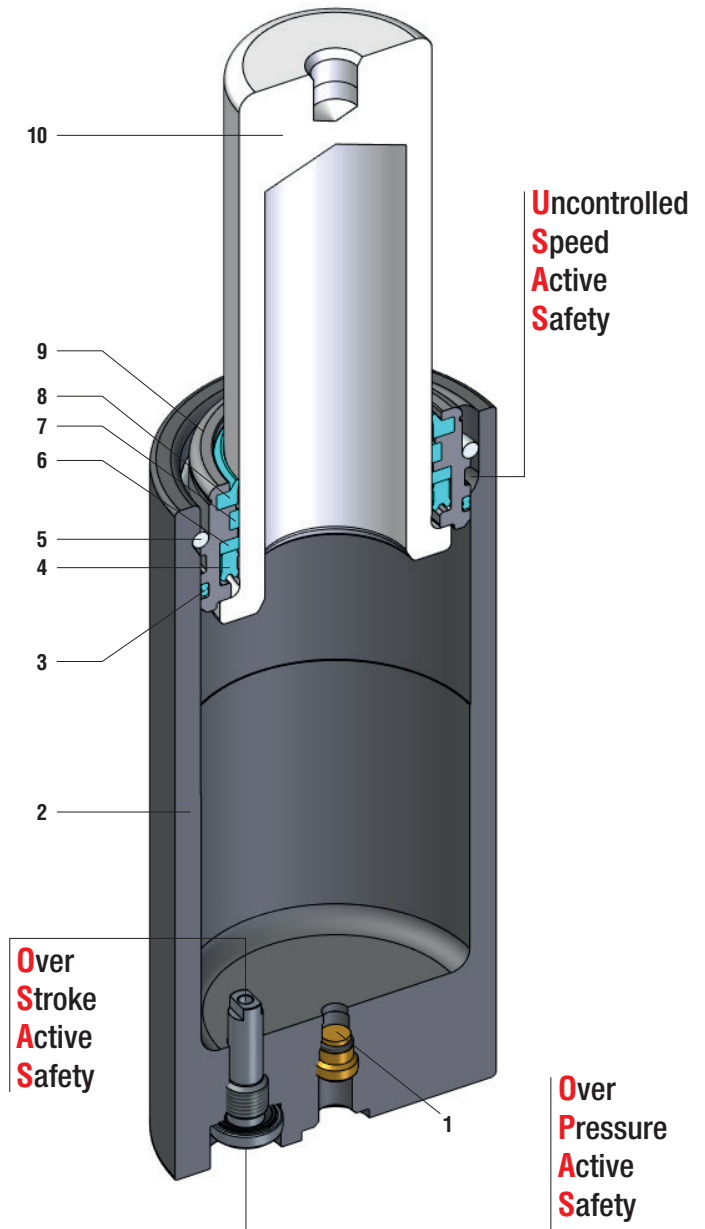

NMX 32 ÷ NMX 50

SEALING	ROD SEAL
DESIGN	BUSH - BODY DESIGN

1	Valve	5	Retaining ring	9	Bush
2	Body	6	Back-up ring	10	Rod (nitrited superfinished)
3	Dual ring seal	7	Guide ring	11	Groove for secondary wiper
4	Rod seal	8	Rod wiper	12	O-ring

RANGE CHART

Model	Body Ø		Stroke Cu		Initial force F0					
	mm	inch	mm	inch	daN	lb	OSAS	USAS	OPAS	SW
NMX 19	19	0.75	10 - 80	0.39 - 3.15	150	337	✓	✓	✓	✓
NMX 25	25	0.98	10 - 80	0.39 - 3.15	300	674	✓	✓	✓	✓
NMX 32	32	1.26	10 - 80	0.39 - 3.15	500	1124	✓	✓	✓	✓
NMX 38	38	1.50	10 - 80	0.39 - 3.15	750	1686	✓	✓	✓	✓
NMX 50	50	1.97	10 - 200	0.39 - 7.87	1500	3372	✓	✓	✓	✓

✓ Built-in as standard ✓ Optional upon request

HOW TO ORDER

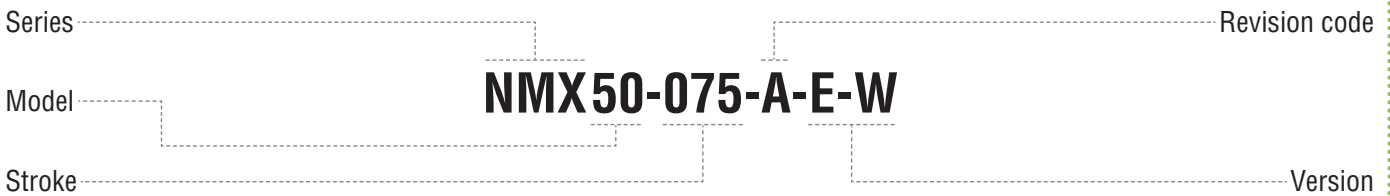

Available versions



NMX 50-075-A
Standard code



Self contained

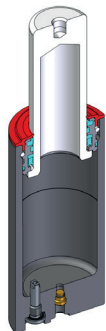

NMX 50-075-A-W
Add "-W" to standard code



Self contained



+
Secondary wiper

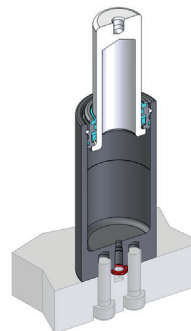

NMX 50-075-A-E
Add "-E" to standard code



Easy
Manifold

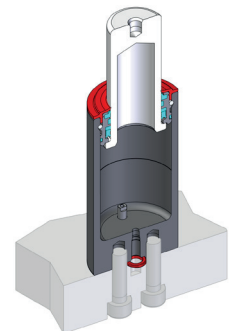

NMX 50-075-A-E-W
Add "-E-W" to standard code



Easy
Manifold



+
Secondary wiper



SW

ACTIVE SAFETY



OSAS



USAS



OPAS

* $F_{1i} =$

Isothermal
end force at 100% Cu p. 18

** $F_{1p} =$

Polytropic
end force at 100% Cu

easu
MANIFOLD

p. 103

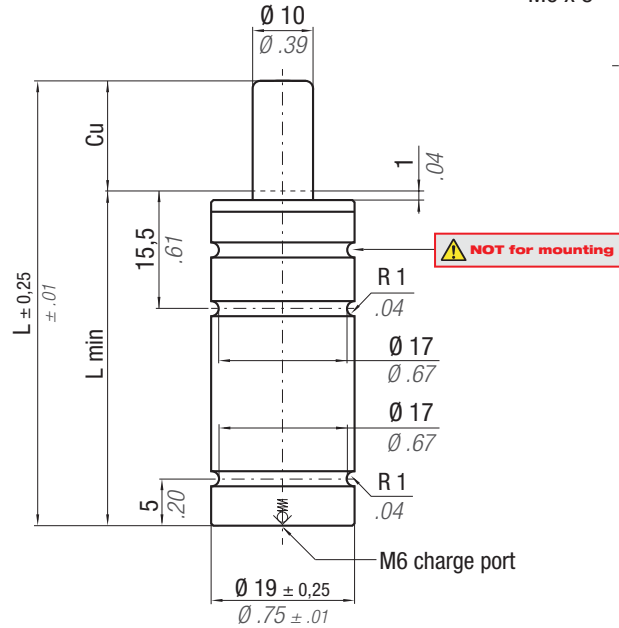
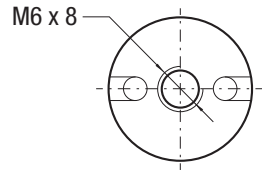

CODE	Cu	L	L min	F ₀ Initial force	F _{1i} *	F _{1p} **	V ₀	Maintenance kit	
								~Kg	~lb

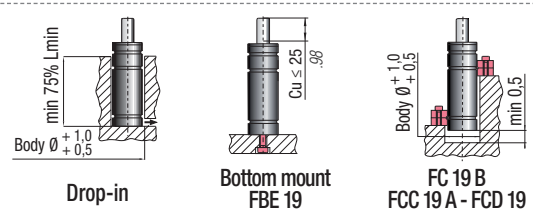

HOW TO ORDER
p. 59

INSTALLATION GUIDELINE
p. 75



ACTIVE SAFETY



OSAS



USAS



OPAS

* $F_{1i} =$

Isothermal end force at 100% Cu

p. 18

** $F_{1p} =$

Polytropic end force at 100% Cu

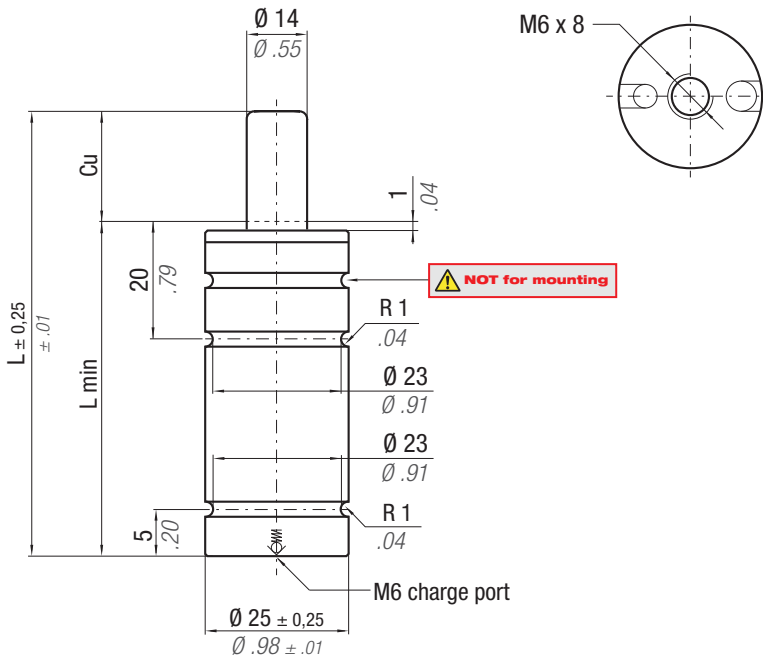

N ₂	0 - 80 °C 32 - 176 °F	ΔP ± 0,33 %/°C	P max 195 bar 2828 psi	P min 20 bar 290 psi	S 1,54 cm ² 0.239 in ²	SPM ~ 20 - 100 (at 20°C)	Max Speed 1,8 m/s 70.8 in/s	Maintenance kit Disposable
----------------	--------------------------	---------------------------	-------------------------------------	-----------------------------------	---	---------------------------------------	--	--------------------------------------

CODE	Cu		L		L min		F ₀		F _{1i} *		F _{1p} **		V ₀		~Kg ~lb		PED 2014/68/EU
	mm	inch	mm	inch	mm	inch	daN	lb	daN	lb	daN	lb	cm ³	in ³			
NMX 25 - 010 - A	10	0.39	60	2.36	50	1.97	300 674 ± 5% 195 bar 2828 psi + 20°C +68°F		441	991	575	1293	6,0	0.37	0,13	0.28	✓
NMX 25 - 015 - A	15	0.59	70	2.76	55	2.17			463	1041	610	1371	8,1	0.49	0,14	0.30	✓
NMX 25 - 025 - A	25	0.98	90	3.54	65	2.56			486	1093	647	1455	12,4	0.76	0,15	0.34	✓
NMX 25 - 038 - A	38	1.50	116	4.57	78	3.07			501	1126	671	1508	17,9	1.09	0,17	0.38	✓
NMX 25 - 050 - A	50	1.97	140	5.51	90	3.54			509	1144	683	1535	23,1	1.41	0,20	0.43	✓
NMX 25 - 080 - A	80	3.15	200	7.87	120	4.72			518	1165	699	1571	35,9	2.19	0,25	0.54	✓

NMX

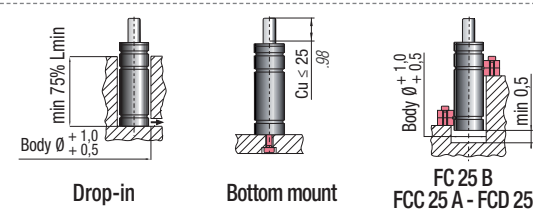

HOW TO ORDER

p. 59

INSTALLATION GUIDELINE

p. 75



SW

**ACTIVE
SAFETY**



OSAS



USAS



OPAS

* $F_{1i} =$

Isothermal
end force
at 100% Cu



p. 18



** $F_{1p} =$

Polytrophic
end force
at 100% Cu

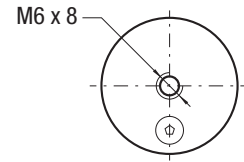
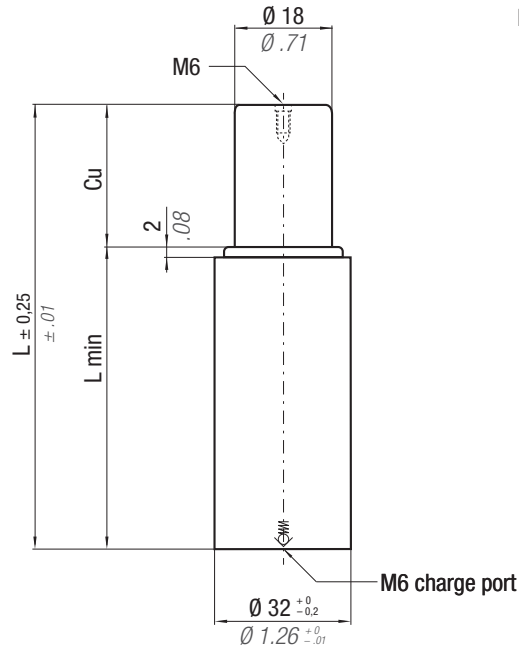

CODE	Cu	L	L min	F ₀ Initial force	F _{1i} *		F _{1p} **		V ₀		Maintenance kit	
					daN	lb	daN	lb	daN	lb	cm ³	in ³

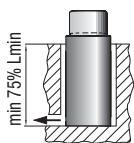

Drop-in



Bottom mount

HOW TO ORDER

p. 59

INSTALLATION GUIDELINE

p. 75



SW

ACTIVE SAFETY



OSAS



USAS



OPAS

* $F_{1i} =$

Isothermal end force at 100% Cu



p. 18



** $F_{1p} =$

Polytropic end force at 100% Cu

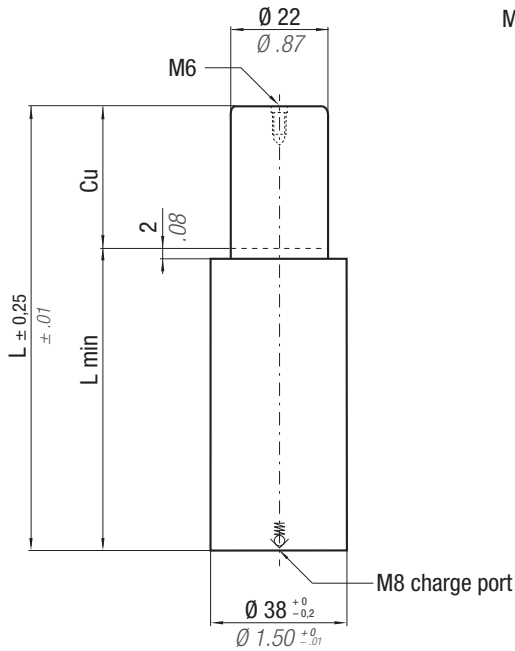
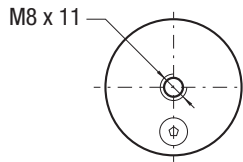

N₂	0 - 80 °C 32 - 176 °F	ΔP ± 0,33 %/°C	P max 197 bar 2857 psi	P min 20 bar 290 psi	S 3,80 cm ² 0.589 in ²	SPM ~ 20 - 100 (at 20°C)	Max Speed 1,8 m/s 70.8 in/s	Maintenance kit 39BMGNS00038A
----------------------	--------------------------	--------------------------	-------------------------------------	-----------------------------------	---	---------------------------------------	--	---

CODE	Cu		L		L min		F ₀		F _{1i} *		F _{1p} **		V ₀		~Kg ~lb		2014/68/EU
	mm	inch	mm	inch	mm	inch	daN	lb	daN	lb	daN	lb	cm ³	in ³			
NMX 38 - 010 - A	10	0.39	65	2.56	55	2.16	750 1686 ± 5% 197 bar 2857 psi + 20°C +68°F		1103	2480	1436	3228	14,8	0.90	0,37	0.80	✓
NMX 38 - 015 - A	15	0.59	75	2.95	60	2.36			1183	2659	1562	3512	19,3	1.18	0,39	0.86	✓
NMX 38 - 025 - A	25	0.98	95	3.74	70	2.75			1278	2873	1715	3855	28,3	1.73	0,44	0.96	✓
NMX 38 - 038 - A	38	1.50	121	4.76	83	3.26			1344	3021	1823	4098	39,9	2.43	0,50	1.10	✓
NMX 38 - 050 - A	50	1.97	145	5.71	95	3.74			1380	3102	1884	4235	50,7	3.09	0,58	1.28	✓
NMX 38 - 080 - A	80	3.15	205	8.07	125	4.92			1430	3215	1966	4420	77,7	4.74	0,70	1.55	✓

NMX

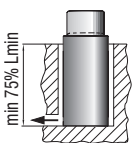

Drop-in



Bottom mount

HOW TO ORDER



p. 59

INSTALLATION GUIDELINE



p. 75



SW

ACTIVE SAFETY



OSAS



USAS



OPAS

* $F_{1i} =$

Isothermal end force at 100% Cu



p. 18



** $F_{1p} =$

Polytropic end force at 100% Cu

easu
MANIFOLD



p. 103

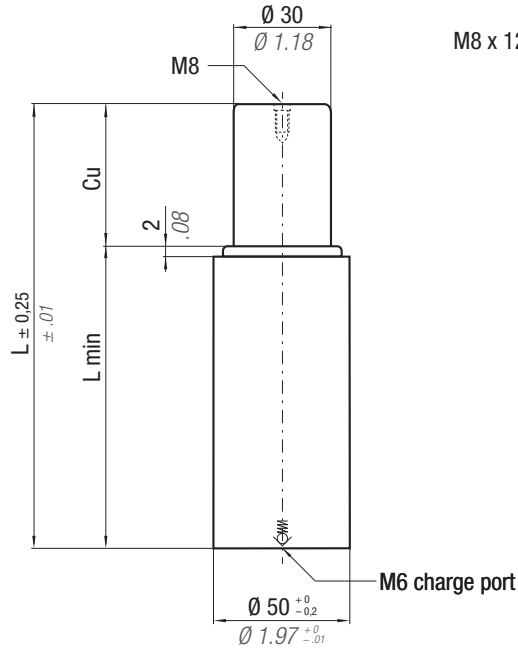

CODE	Cu	L	L min	F ₀ Initial force	* F _{1i}		** F _{1p}		V ₀	Maintenance kit	
					daN	lb	daN	lb		daN	lb
◆ NMX 50 - 010 - A	10	70	60	1500 ± 5% 212 bar 3074 psi + 20°C +68°F	2116	4757	2698	6065	31,1	1,90	39BMNML00050A Cu 25 ÷ 100
NMX 50 - 025 - A	25	100	75		2453	5515	3211	7219	57,4	3,50	39BMNMX00050A Cu 125 ÷ 200
NMX 50 - 038 - A	38	126	88		2588	5818	3421	7691	80,2	4,89	
NMX 50 - 050 - A	50	150	100		2664	5989	3539	7956	101,2	6,17	
NMX 50 - 063 - A	63	176	113		2719	6113	3627	8154	124,0	7,56	
NMX 50 - 080 - A	80	210	130		2768	6223	3704	8327	153,8	9,38	
NMX 50 - 100 - A	100	250	150		2790	6272	3738	8403	190,3	11,61	
NMX 50 - 125 - A	125	315	190		2786	6263	3732	8390	238,3	14,54	
NMX 50 - 160 - A	160	395	235		2772	6232	3710	8340	307,0	18,73	
NMX 50 - 200 - A	200	475	275		2811	6319	3771	8478	377,1	23,00	

◆ Disposable

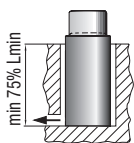

Drop-in



Bottom mount

HOW TO ORDER



p. 59

INSTALLATION GUIDELINE



p. 75



NMX

THIS PAGE IS INTENTIONALLY LEFT BLANK

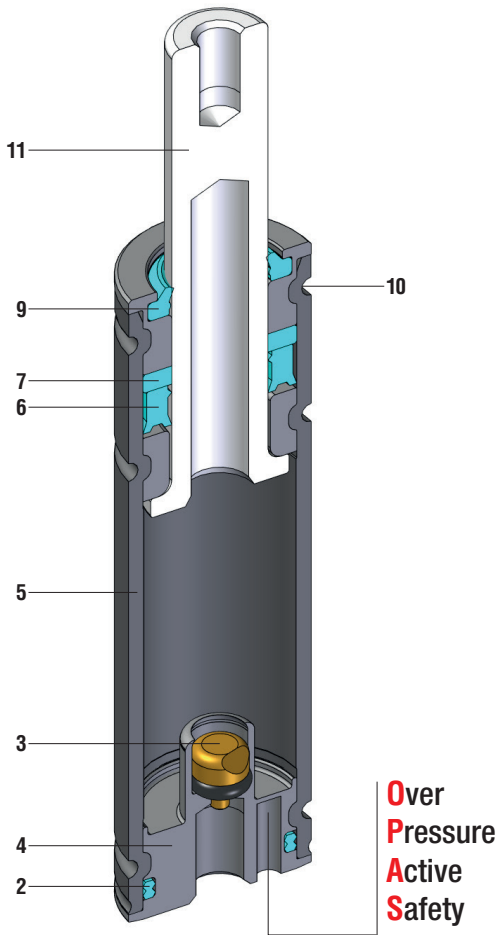

NMC 19

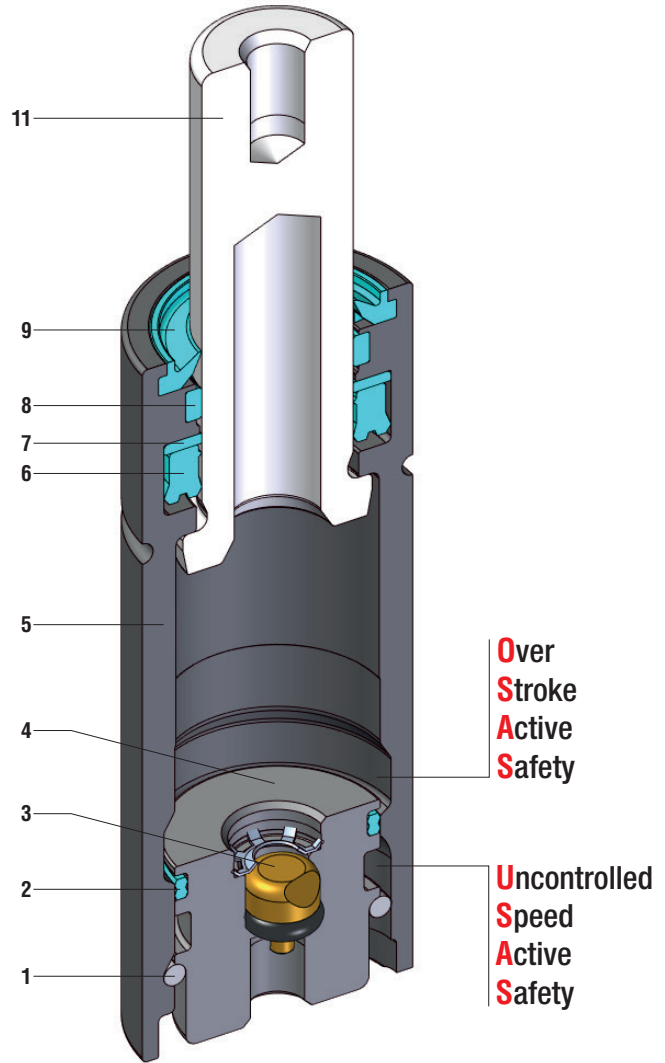

NMC 25

SEALING	ROD SEAL
DESIGN	BOTTOM BASE - BODY DESIGN

1	Retaining ring	5	Body	9	Rod wiper
2	Dual ring seal	6	Rod seal	10	Groove for secondary wiper
3	Valve	7	Back-up ring	11	Rod (nitrited superfinished)
4	Bottom base	8	Guide ring		

RANGE CHART

Model	Body Ø		Stroke Cu		Initial force F0					
	mm	inch	mm	inch	daN	lb	OSAS	USAS	OPAS	SW
NMC 19	19	0.75	10 - 80	0.39 - 3.15	80	180	-	-	✓	✓
NMC 25	25	0.98	10 - 80	0.39 - 3.15	160	360	✓	✓	-	-

✓ Built-in as standard
✓ Optional upon request



HOW TO ORDER

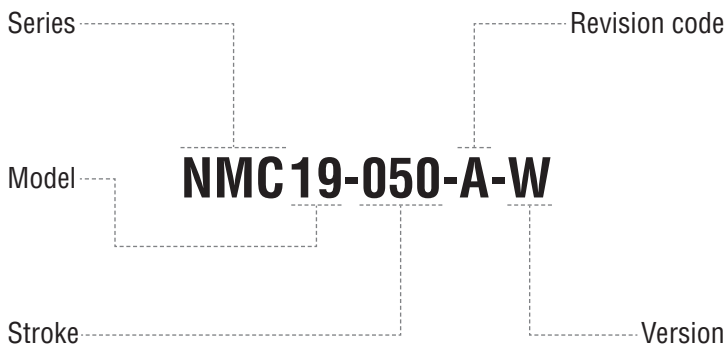

Available versions

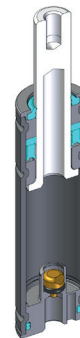

NMC 19-050-A
Standard code



Self contained

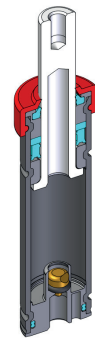

NMC 19-050-A-W
Add "-W" to standard code



Self contained

+



Secondary wiper



SW

ACTIVE SAFETY



OPAS

* $F_{1i} =$

Isothermal end force at 100% Cu  p. 18

** $F_{1p} =$

Polytropic end force at 100% Cu 

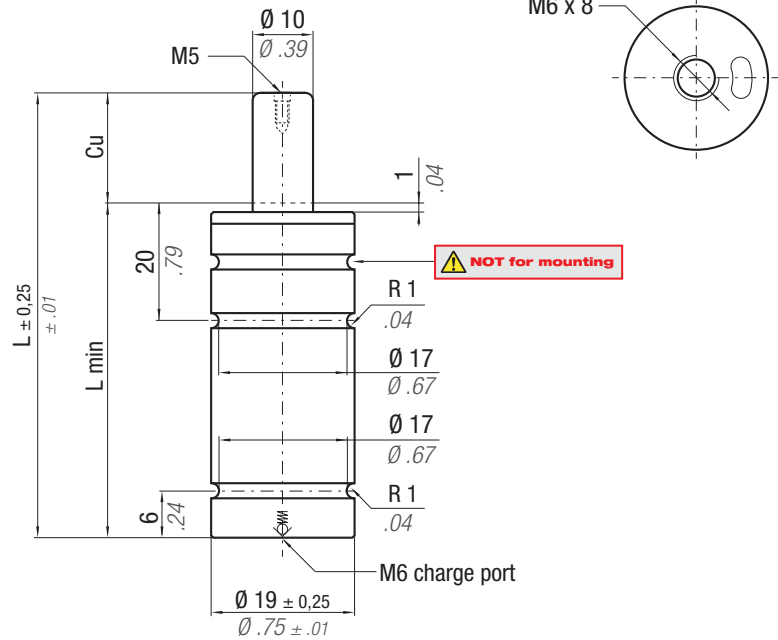

CODE	Cu	L	L min	F ₀ Initial force	F _{1i} *		F _{1p} **		V ₀		Maintenance kit	
					daN	lb	daN	lb	daN	lb	cm ³	in ³
NMC 19 - 010 - A	10	65	55	80 ± 5% 102 bar 1479 psi +20°C +68°F	101	227	135	303	4,0	0,24	0,08	0,17
NMC 19 - 015 - A	15	75	60		106	238	144	324	5,2	0,32	0,08	0,18
NMC 19 - 025 - A	25	95	70		112	252	156	351	7,4	0,45	0,09	0,20
NMC 19 - 038 - A	38	121	83		116	261	164	369	10,4	0,63	0,11	0,23
NMC 19 - 050 - A	50	145	95		118	265	169	380	13,1	0,80	0,12	0,26
NMC 19 - 080 - A	80	205	125		122	274	175	393	19,8	1,21	0,15	0,33

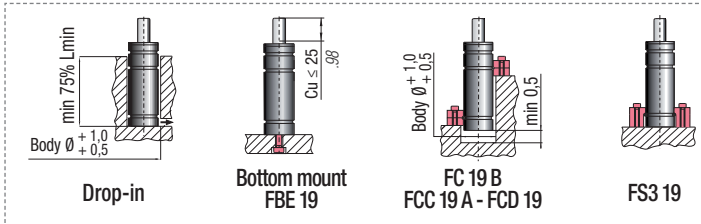

HOW TO ORDER
 p. 67

INSTALLATION GUIDELINE
 p. 75

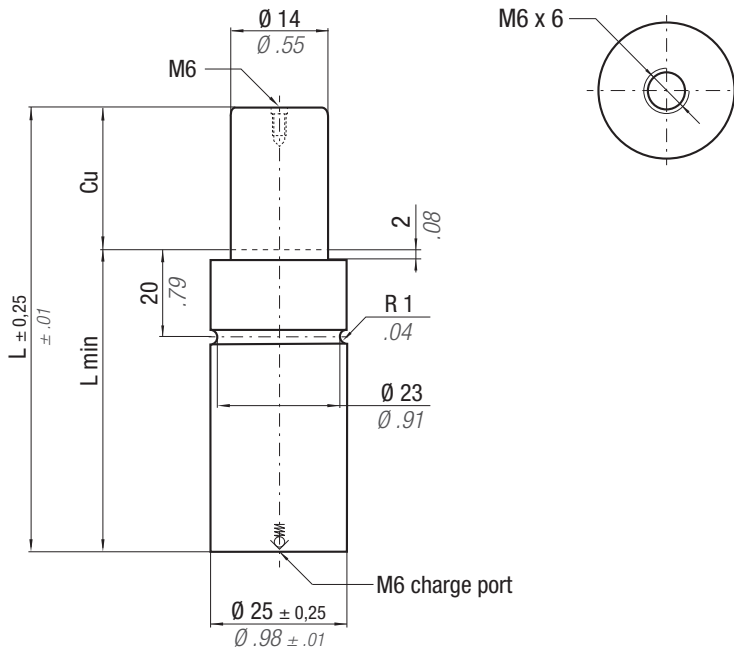

* F_{1i} = Isothermal end force at 100% Cu p. 18

** F_{1p} = Polytrophic end force at 100% Cu

ACTIVE SAFETY



OSAS



USAS

	0 - 80 °C 32 - 176 °F	ΔP ± 0,33 %/°C	P max 102 bar 1479 psi	P min 20 bar 290 psi	S 1,54 cm ² 0.239 in ²	SPM ~ 20 - 100 (at 20°C)	Max Speed 1,8 m/s 70.8 in/s	Maintenance kit Disposable
--	--------------------------	---------------------------	-------------------------------------	-----------------------------------	---	---------------------------------------	--	--------------------------------------

CODE	Cu		L		L min		F ₀		F _{1i} *		F _{1p} **		V ₀		Weight		PED 2014/68/EU
	mm	inch	mm	inch	mm	inch	daN	lb	daN	lb	daN	lb	cm ³	in ³	~Kg	~lb	
NMC 25 - 010 - A	10	0.39	65	2.56	55	2.16	160 1360 ± 5% 102 bar 1479 psi + 20°C +68°F		237	533	342	769	4,9	0.30	0,15	0.32	✓
NMC 25 - 015 - A	15	0.59	75	2.95	60	2.36			252	567	373	839	6,5	0.40	0,16	0.35	✓
NMC 25 - 025 - A	25	0.98	95	3.74	70	2.75			269	605	409	919	9,9	0.60	0,18	0.40	✓
NMC 25 - 038 - A	38	1.50	121	4.76	83	3.26			280	629	434	976	14,2	0.87	0,22	0.47	✓
NMC 25 - 050 - A	50	1.97	145	5.71	95	3.74			286	643	447	1005	18,2	1.11	0,25	0.54	✓
NMC 25 - 080 - A	80	3.15	205	8.07	125	4.92			294	661	465	1045	28,2	1.72	0,32	0.70	✓

NMC

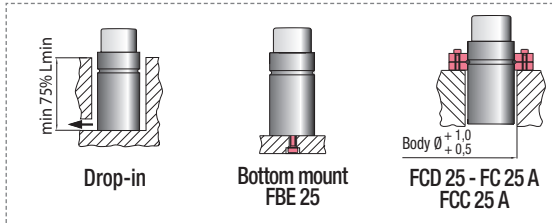

HOW TO ORDER
p. 67

INSTALLATION GUIDELINE
p. 75

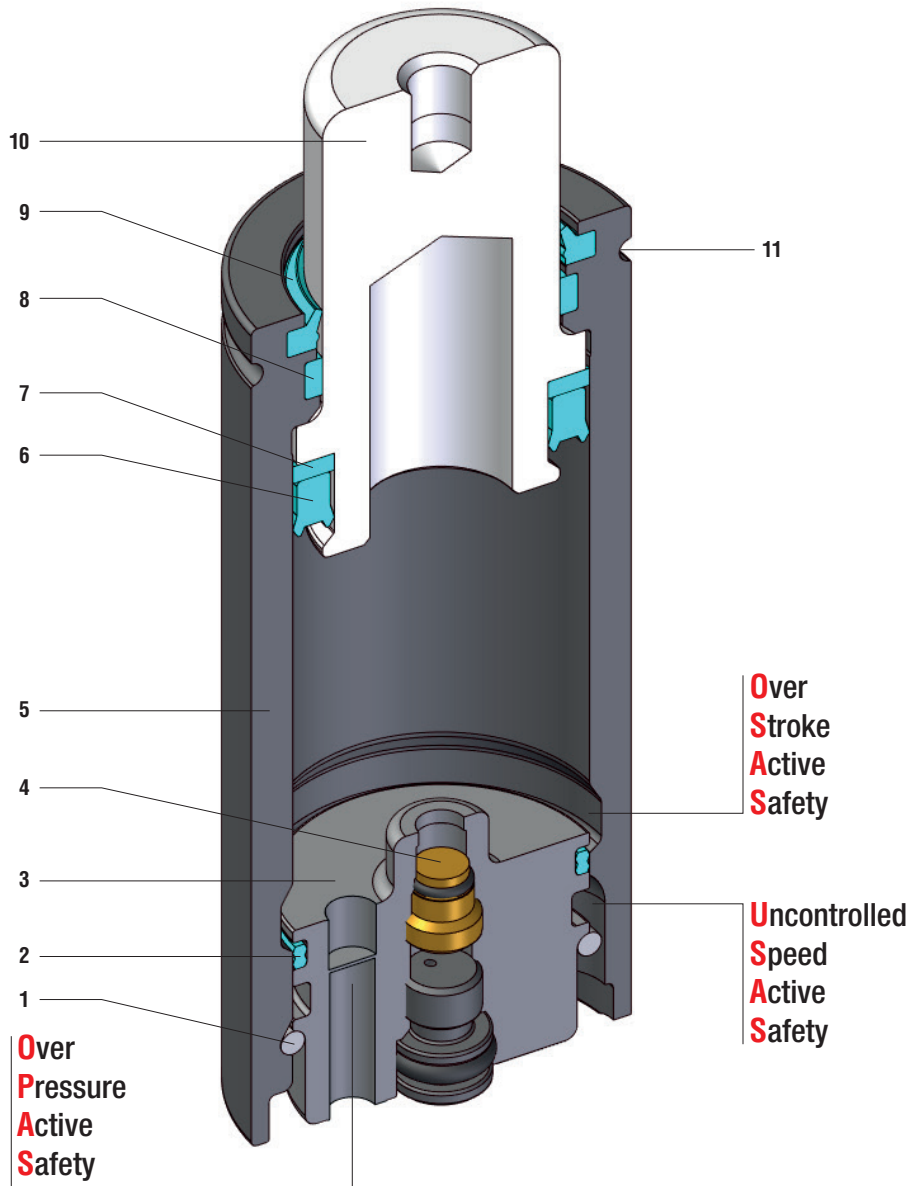

SEALING	PISTON SEAL
DESIGN	BOTTOM BASE - BODY DESIGN

1	Retaining ring	5	Body	9	Rod wiper
2	Dual ring seal	6	Piston seal	10	Rod (nitrited superfinished)
3	Bottom base	7	Back-up ring	11	Groove for secondary wiper
4	Valve	8	Guide ring		

RANGE CHART

Model	Body Ø		Stroke Cu		Initial force F0		OSAS	USAS	OPAS	SW
	mm	inch	mm	inch	daN	lb				
NT 25	25	0.98	10 - 50	0.39 - 1.97	400	899	✓	✓	✓	-
NT 32	32	1.26	10 - 50	0.39 - 1.97	700	1574	✓	✓	✓	✓

✓ Built-in as standard
✓ Optional upon request

HOW TO ORDER

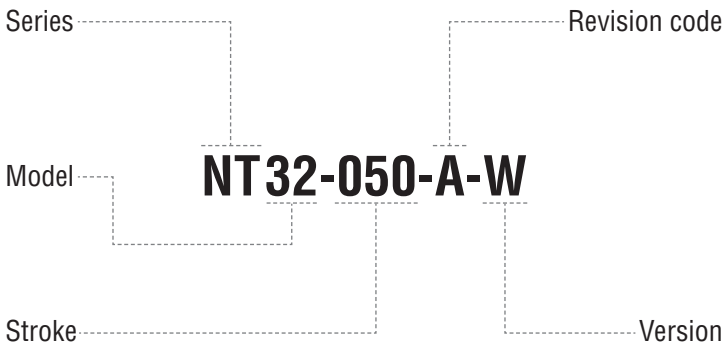

Available versions

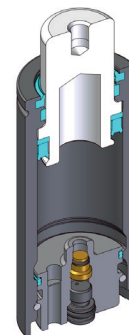

NT 32-050-A
Standard code



Self contained

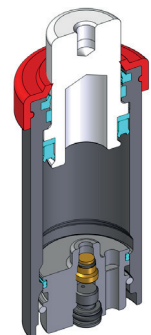

NMC 32-050-A-W
Add "-W" to standard code



Self contained



+
Secondary wiper

ACTIVE SAFETY



OSAS



USAS



OPAS

* $F_{1i} =$

Isothermal end force at 100% Cu p. 18

** $F_{1p} =$

Polytrophic end force at 100% Cu

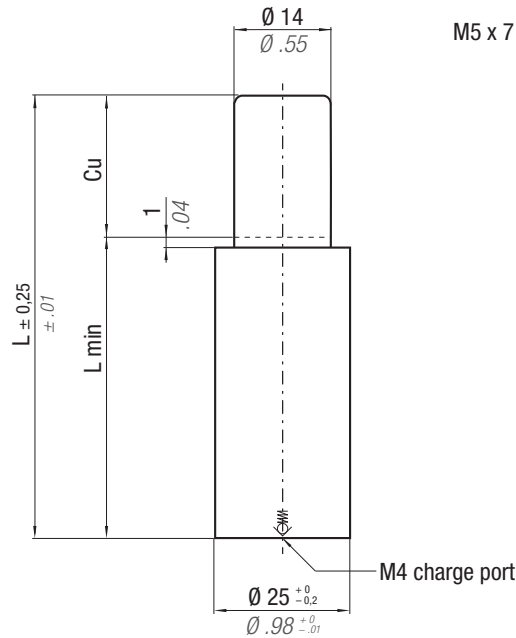

CODE		0 - 80 °C 32 - 176 °F	ΔP ± 0,33 %/°C	P max 141 bar 2045 psi	P min 20 bar 290 psi	S 2,84 cm ² 0,440 in ²	SPM ~ 20 - 100 (at 20°C)	Max Speed 1,8 m/s 70.8 in/s	Maintenance kit Disposable	Cu		L		L min		F ₀ Initial force		F _{1i} * End force *		F _{1p} ** End force **		V ₀		~Kg ~lb			
										mm	inch	mm	inch	mm	inch	daN	lb	daN	lb	daN	lb	cm ³	in ³				
NT 25 - 010 - A											10	0.39	75	2.95	65	2.56	400	899	631	1419	887	1994	8,8	0.54	0,16	0.35	✓
NT 25 - 015 - A											15	0.59	90	3.54	75	2.95	± 5%	672	1511	966	2175	11,9	0.73	0,18	0.40	✓	
NT 25 - 025 - A											25	0.98	120	4.72	95	3.74	141 bar 2045 psi	718	1614	1054	2369	18,0	1.10	0,22	1.85	✓	
NT 25 - 050 - A											50	1.97	195	7.68	145	5.71	+ 20°C +68°F	762	1713	1143	2570	33,5	2.04	0,31	2.62	✓	

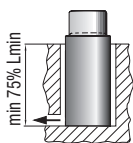

Drop-in

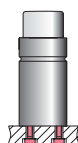

Bottom mount

HOW TO ORDER

p. 71

INSTALLATION GUIDELINE

p. 75



SW

ACTIVE SAFETY



OSAS



USAS



OPAS

* $F_{1i} =$

Isothermal end force at 100% Cu



p. 18



** $F_{1p} =$

Polytropic end force at 100% Cu

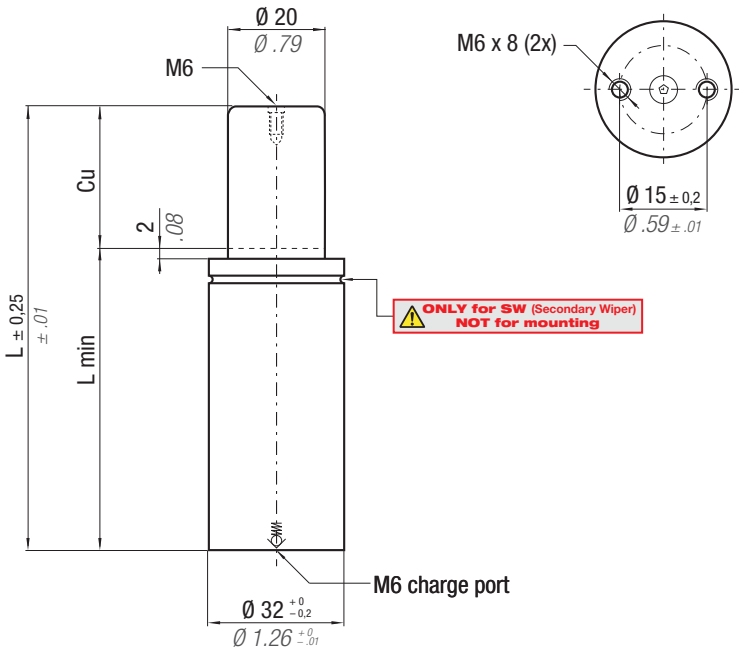

**ONLY for SW (Secondary Wiper)
NOT for mounting**

	N_2	0 - 80 °C 32 - 176 °F	ΔP ± 0,33 %/°C	P max 142 bar 2059 psi	P min 20 bar 290 psi	S 4,91 cm ² 0.761 in ²	SPM ~ 20 - 100 (at 20°C)	Max Speed 1,8 m/s 70.8 in/s	Maintenance kit Disposable
--	-------	--------------------------	---------------------------	-------------------------------------	-----------------------------------	---	---------------------------------------	--	--------------------------------------

CODE	Cu		L		L min		F ₀ Initial force		F _{1i} * End force *		F _{1p} ** End force **		V ₀		~Kg ~lb		
	mm	inch	mm	inch	mm	inch	daN	lb	daN	lb	daN	lb	cm ³	in ³			
NT 32 - 010 - A	10	0.39	75	2.95	65	2.56	700	1574	1063	2390	1473	3311	16,3	0.99	0,28	0.62	✓
NT 32 - 015 - A	15	0.59	90	3.54	75	2.95	± 5%		1133	2547	1605	3608	21,7	1.32	0,31	0.68	✓
NT 32 - 025 - A	25	0.98	120	4.72	95	3.74	142 bar		1211	2722	1757	3950	32,7	1.99	0,38	0.84	✓
NT 32 - 050 - A	50	1.97	195	7.68	145	5.71	+20°C +68°F		1292	2905	1915	4305	60,1	3.67	0,54	1.19	✓

NT

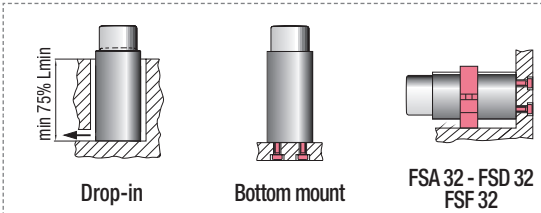

Drop-in

Bottom mount

FSA 32 - FSD 32
FSF 32

HOW TO ORDER

p. 71

INSTALLATION GUIDELINE

p. 75

THIS PAGE IS INTENTIONALLY LEFT BLANK

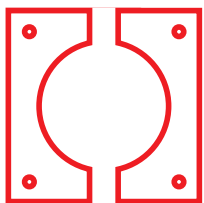

INSTALLATION GUIDELINE

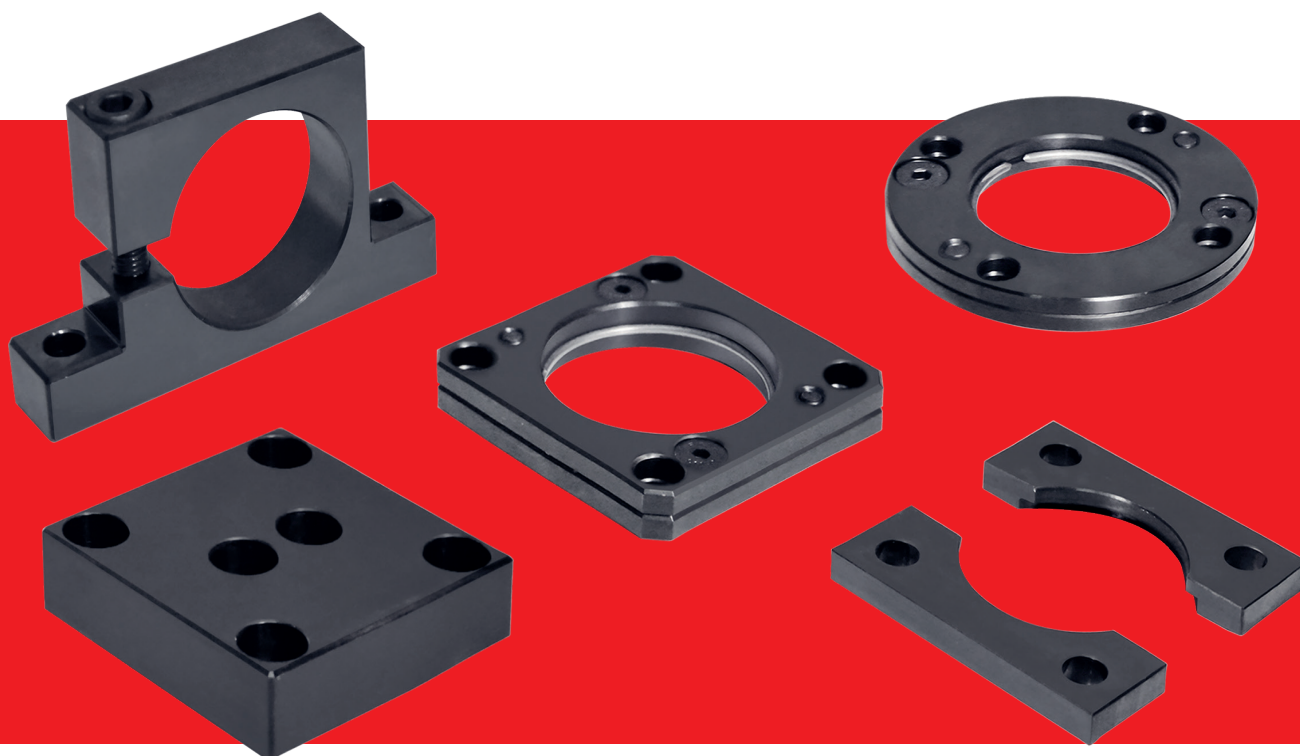

INSTALLATION GUIDELINE



- IT** Un corretto fissaggio dei cilindri ad azoto previene danni ai prodotti e gravi pericoli agli operatori.
- EN** A correct fixing of the gas springs prevents damages to products and serious dangers to operators.
- DE** Die richtige Befestigung der Gasdruckfeder verhindert Schäden an den Produkten und ernsthafte Gefahren für das Personal.
- FR** La fixation correcte du ressort à gaz évite des dommages aux produits et des dangers graves pour les opérateurs.
- ES** Una correcta fijación del cilindro de gas previene daños a los productos y graves peligros a los operadores.
- PT** Uma correta fixação do cilindro pode prevenir danos ao produto e também ao operador.

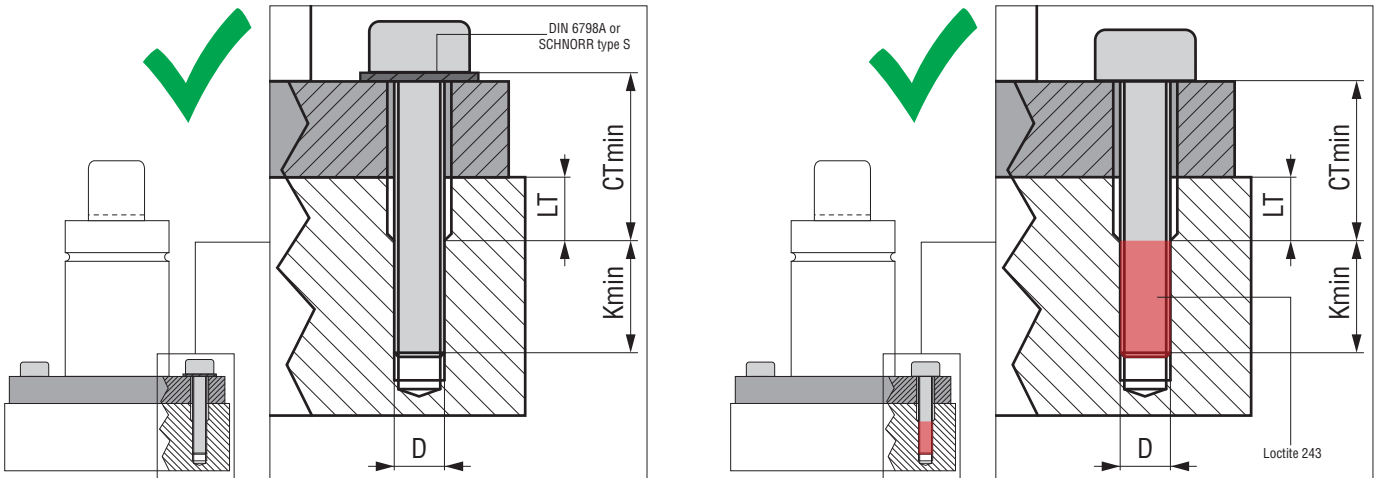

CTmin	Kmin	LT
Lunghezza libera (min. 2 x D)	Minimo impegno viti (acciaio = min. 1.5 x D, ghisa = min. 2 x D)	Allargamento per garantire CTmin
Free length (min. 2 x D)	Minimum thread engagement (steel = min. 1.5 x D, cast iron = min. 2 x D)	Widening to ensure CTmin
Klemmlänge (min. 2 x D)	Mindest-Einschraublänge (Stah = min. 1.5 x D, Guss = min. 2 x D)	Bohrung zur Gewährleistung der CTmin
Longueur libre (min. 2 x D)	Longueur minimum à visser (acier = min. 1.5 x D, fonte = min. 2 x D)	Élargissement pour assurer CTmin
Longitud libre (min. 2 x D)	Longitud mínima de roscado (acero = min. 1.5 x D, fundición = min. 2 x D)	Margen para garantizar CTmin
Comprimento livre (min. 2 x D)	Comprimento mínimo roscado (aço 1,5 x D – Fundido 2,0 x D)	Alívio para garantir o CT min

- IT** Utilizzare sempre apposito frenafiletto e/o rondelle di sicurezza su tutte le viti di fissaggio. (Non rappresentate nei disegni delle pagine seguenti).
- EN** Always use the suitable threadlocker and/or safety washers on all fixing screws. (They are not represented in the drawings in the following pages of the catalog).
- DE** Verwenden Sie immer geeignete Schraubensicherungen und/oder Sicherungsscheiben an allen Befestigungsschrauben. (Nicht in den Zeichnungen auf den folgenden Seiten dargestellt).
- FR** Utilisez toujours le frein filet approprié et/ou les rondelles de sécurité sur toutes les vis de fixation. (Ils ne sont pas représentés sur les dessins dans les pages suivantes du catalogue).
- ES** Utilice siempre un adhesivo fijador de roscas adecuado y/o arandelas de seguridad en todos los tornillos de fijación. (No están representados en los dibujos de las páginas siguientes).
- PT** Sempre utilizar o trava roscas e/ou arruela de segurança em todos os parafusos de fixação (não estão representados nas próximas páginas do catalogo).



Rondelle di sicurezza - Safety Washers
Sicherungsscheiben - Rondelles de sécurité
Arandelas de seguridad - Arruela de segurança

Only for NCS, NMC,
NT series



Conical spring
washer provided
by Special Springs



DIN 6798A
or
SCHNORR type S

- IT** L' uso di viti di classe superiore alla 8.8, come 9.8, 10.9 e 12.9, è sempre possibile. Si raccomanda di NON SUPERARE i valori della coppia di serraggio indicati per la classe 8.8 per qualsiasi classe di viti utilizzata (vedi pag. 79).
- EN** It is always possible to use screws belonging to Classes higher than 8.8, such as 9.8, 10.9 and 12.9. Do NOT EXCEED the values of the tightening torque valid for Class 8.8 for any of the screw's Classes you may use (see page 79).
- DE** Die Verwendung von Schrauben von höheren Klassen als 8.8, wie 9.8, 10.9 und 12.9 ist immer möglich. Es wird empfohlen, die für die Klasse 8.8 angegebenen Anziehdrehmomente für alle verwendeten Schraubenklassen nicht zu überschreiten (voir page 79)
- FR** L' est toujours possible d'utiliser des vis appartenant aux classes supérieures à 8.8, telles que 9.8, 10.9 et 12.9. NE PAS DÉPASSER les valeurs du couple de serrage indiquées pour la classe 8.8 pour n'importe quelle classe de résistance que vous allez utiliser (voir page 79).
- ES** El uso de tornillos de calidad superior a 8.8, como 9.8, 10.9 y 12.9 está permitido. Se recomienda NO EXCEDER el par de apriete indicado para la clase 8.8 para cualquier calidad de tornillos utilizados (consulte la página 79).
- PT** Sempre é possível usar parafusos pertencentes a classes superiores a 8.8, como 9.8, 10.9 e 12.9. NÃO SUPERAR os valores do torque recomendado para os parafusos da classe 8.8, mesmo que esteja utilizando parafusos com classes diferentes, (ver página 79).

- IT** Cilindro ad azoto con fori di fissaggio in cui il valore di A è maggiore del valore D (esempio NCS38 con fori di fissaggio M6x10).
- EN** Gas spring with fixing holes for which value A is bigger than value D (e.g. NCS38 with fixing holes M6x10).
- DE** Gasdruckfeder mit Befestigungsbohrungen bei denen der Wert A größer als der Wert D ist (Beispiel NCS38 mit Befestigungsbohrungen M6x10).
- FR** Ressort à gaz avec trous de fixation dans lequel la valeur A est supérieure à la valeur D (par exemple, NCS38 avec trous de fixation M6x10).
- ES** Cilindro de gas con agujeros de fijación en el que el valor A es mayor que el valor D (ejemplo NCS38 con agujeros de fijación M6x10).
- PT** Cilindros com furos de fixação que a medida A é maior que a medida D (ex. NCS38 com furos de fixação M6x10).

Installation Example: $A > D$

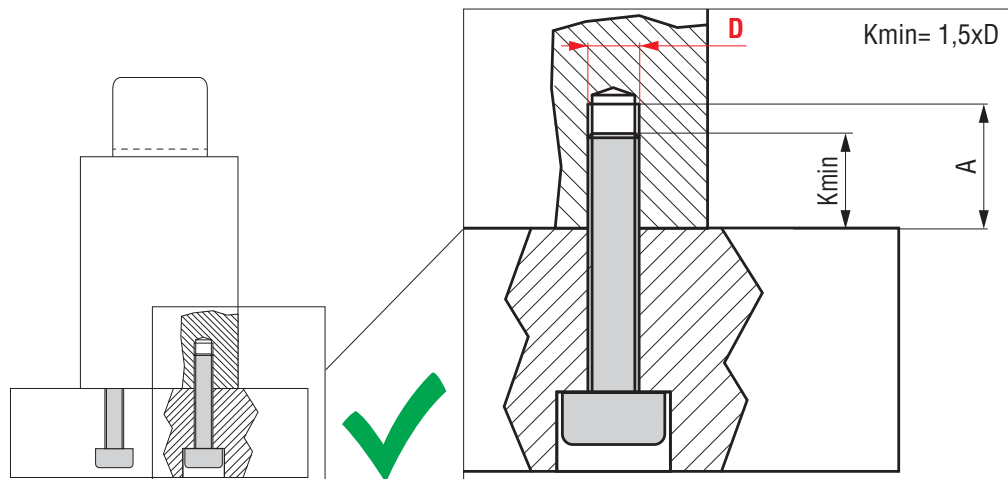

- IT** Cilindro ad azoto in cui il valore A è minore del valore D (esempio NML50 con fori di fissaggio M10x12). Attenzione: in questi casi utilizzare viti con lunghezza tale da impegnare l'intera profondità utile di fissaggio.
- EN** Gas spring with fixing holes for which value A is smaller than value D (e.g. NML50 with fixing holes M10x12). In such cases, be careful to use screws with a length long enough to employ the whole usable fixing depth.
- DE** Gasdruckfeder bei der der Wert A kleiner als der Wert D ist (Beispiel NML50 mit Befestigungsbohrungen M10x12). Achtung: Verwenden Sie in diesen Fällen Schrauben mit einer Länge, die über die gesamte Einschraublänge reicht.
- FR** Ressort à gaz avec trous de fixation dans lequel la valeur A est inférieure à la valeur D (par exemple, NML50 avec trous de fixation M10x12). Dans ce cas, veuillez utiliser des vis suffisamment longues pour utiliser toute la profondeur de fixation utilisable.
- ES** Cilindro de gas en el que el valor A es menor que el valor D (ejemplo NML50 con agujeros de fijación M10x12). Atención: en estos casos utilizar tornillos con una longitud que permita utilizar toda la profundidad útil de fijación.
- PT** Cilindros que a medida A é menor que a medida D (ex. NML50 com furos de fixação M10x12). Neste caso, atentar para que o comprimento do parafuso seja suficiente para garantir o comprimento mínimo de roscado na placa.

Installation Example: $A \leq D$

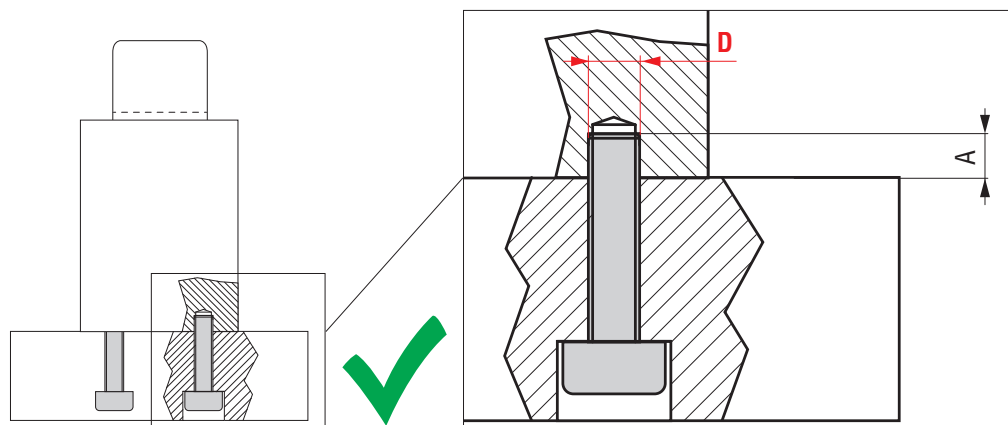

INSTALLATION GUIDELINE

IT Le viti di fissaggio non devono mai essere sollecitate direttamente dal carico agente sul cilindro ad azoto.

EN Fixing screws shall never be directly strained by the load acting on the gas spring.

DE Die Befestigungsschrauben dürfen niemals direkt durch die auf die Gasdruckfeder wirkende Last belastet werden.



FR Les vis de fixation ne doivent jamais être directement sollicitées par la charge agissant sur le ressort à gaz.

ES Los tornillos de fijación nunca deben recibir directamente la carga que se aplica sobre el cilindro de gas.

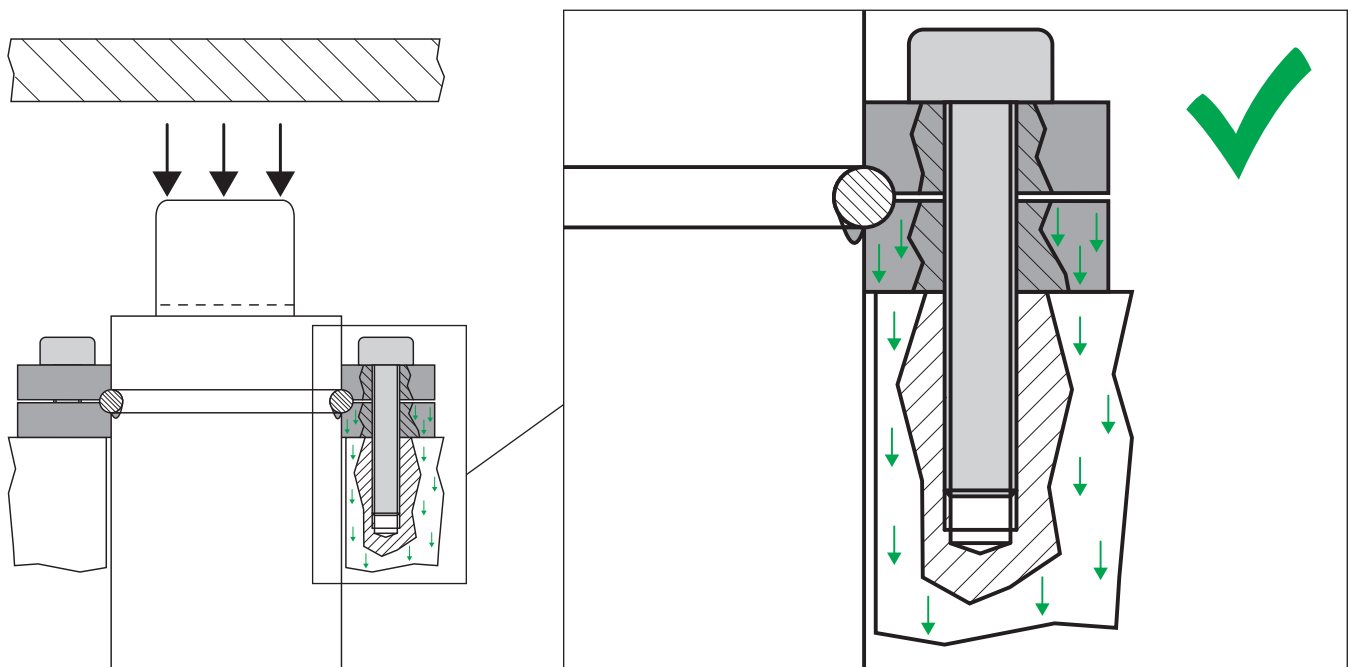
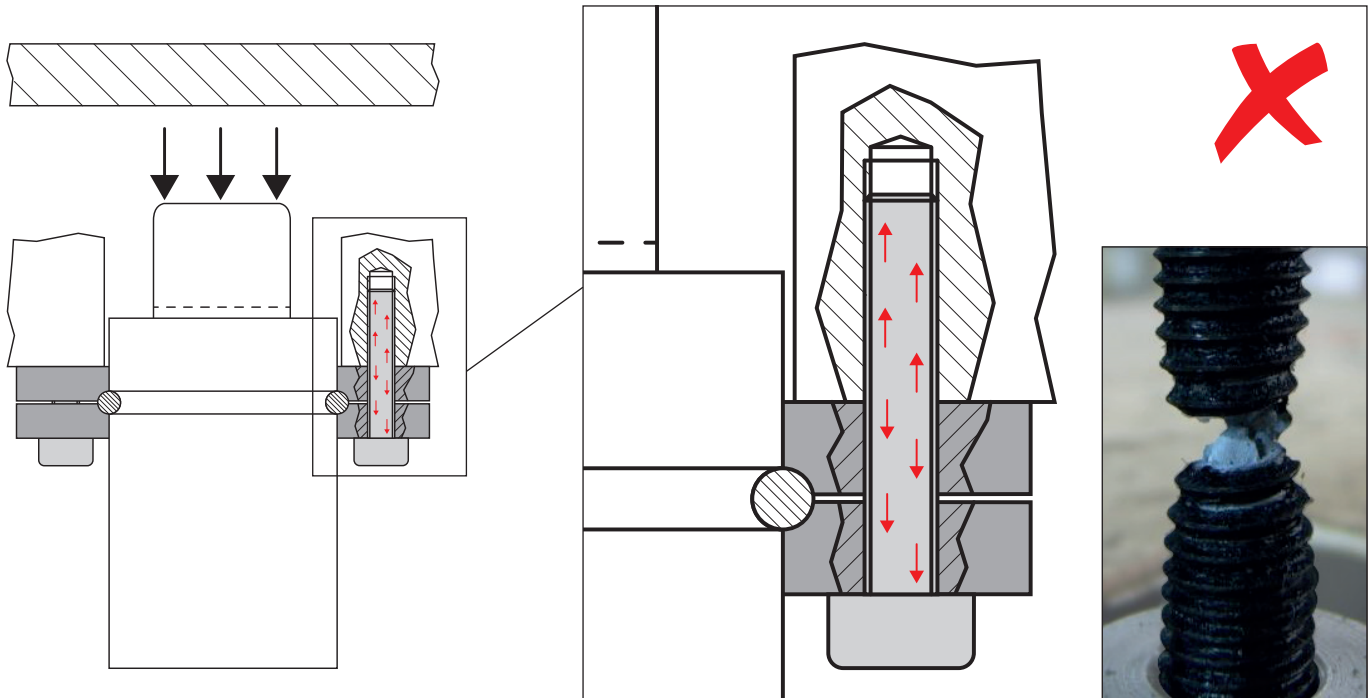
PT Os parafusos de fixação jamais devem receber diretamente a carga do cilindro.



- IT** Rispettare le coppie di serraggio prescritte e verificare sempre lo stato dei cilindri ad azoto e dei fissaggi ad ogni intervento sullo stampo.
- EN** Respect the specified tightening torques and verify always the condition of gas springs and fixings at each intervention on the die.
- DE** Beachten Sie die vorgeschriebenen Anziehdrehmomente und überprüfen Sie bei jedem Eingriff am Werkzeug den Zustand der Gasdruckfedern und Befestigungen.
- FR** Respectez les couples de serrage spécifiés et vérifiez les conditions des ressorts à gaz et des fixations à chaque intervention sur le moule.
- ES** Respete los pares de apriete indicados y verifique el estado de los cilindros de gas y de las fijaciones en cada intervención en el troquel.
- PT** Respeitar o torque dos parafusos especificado e a cada parada para manutenção da ferramenta deve ser verificado as condições dos cilindros e das flanges.

	UNI EN ISO 21269:2007 class ≥ 8.8	M5	M6	M8	M10	M12	M 16
	Torque force	6 Nm	10 Nm	24 Nm	50 Nm	84 Nm	205 Nm

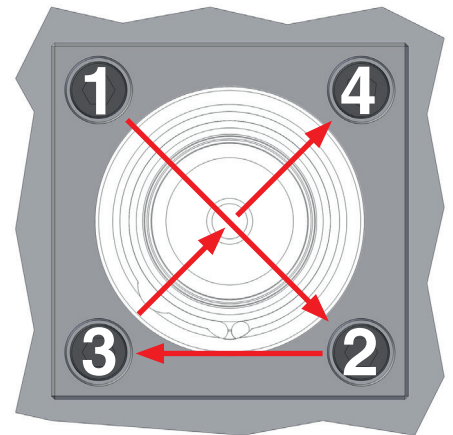
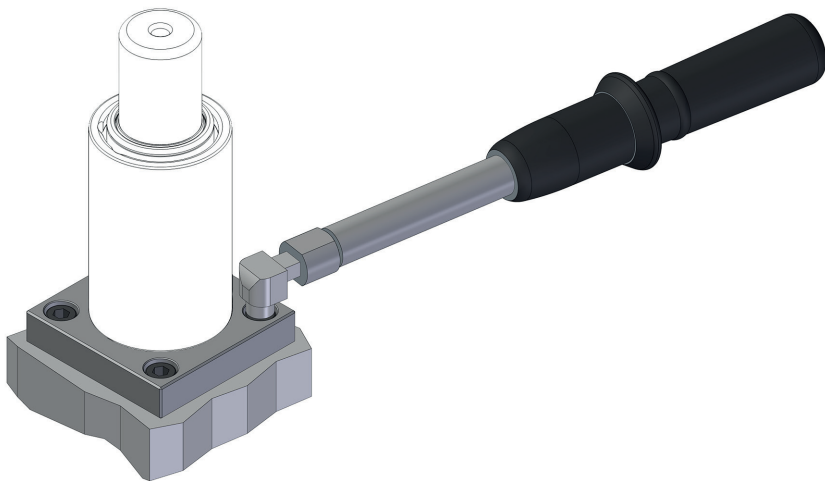

- IT** Serrare tutte le viti di fissaggio seguendo l'ordine a croce (1, 2, 3, 4) applicando la coppia di serraggio corretta. In questo modo il cilindro ad azoto sarà perfettamente posizionato.
- EN** Tighten all fixing screws by following the order shown in the image (1, 2, 3, 4) and by applying the correct tightening torque. In doing so, the gas springs will be perfectly positioned.
- DE** Alle Befestigungsschrauben über Kreuz in der Reihenfolge 1, 2, 3, 4 (s. Bild) mit dem richtigen Anziehdrehmoment anziehen. Auf diese Weise wird die Gasdruckfeder perfekt positioniert.
- FR** Serrez toutes les vis de fixation en respectant l'ordre indiqué sur l'image (1, 2, 3, 4) et en appliquant le couple de serrage approprié. Ce faisant, les ressorts à gaz seront parfaitement positionnés.
- ES** Apriete todos los tornillos de fijación siguiendo el orden que se muestra en la imagen (1, 2, 3, 4) y aplicando el par de apriete correcto. Al hacerlo, los resortes de gas estarán perfectamente posicionados.
- PT** Os parafusos devem ser apertados seguindo a ordem do desenho (1,2,3,4) e aplicado o torque correto. Dessa forma os cilindros estarão perfeitamente fixados.

INSTALLATION GUIDELINE - DROP-IN



Esempi di installazione - Installation examples - Montagebeispiele - Exemples d'installation - Ejemplos de instalación - Exemplo de instalação

- IT** I cilindri ad azoto devono essere sempre installati perpendicolarmente rispetto alla direzione di trasmissione della forza.
- EN** Gas springs must always be installed perpendicular to the direction of force transmission.
- DE** Die Gasdruckfedern müssen immer lotrecht hinsichtlich der Richtung der Kraftübertragung eingebaut werden.
- FR** Les ressorts à gaz doivent toujours être installés perpendiculairement à la direction de la transmission de la force.
- ES** Los cilindros de gas siempre deben ser instalados perpendicularmente respecto a la dirección de transmisión de la fuerza.
- PT** Os Cilindros de Nitrogenio devem sempre ser instalados perpendicular a direção da força de acionamento.

- IT** I fori di alloggiamento in cui vengono installati i cilindri ad azoto devono sempre essere provvisti di fori di drenaggio.
- EN** The housing holes where the gas springs are installed must always have drain holes.
- DE** Die Gehäusebohrungen, in den die Gasdruckfedern eingebaut werden, müssen immer ein Drainage Loch haben.
- FR** Les logements de l'outil où sont installés les vérins à gaz doivent toujours avoir des trous de drainage.
- ES** Los agujeros en los que se instalan los cilindros siempre deben tener agujeros de drenaje.
- PT** Os alojamentos dos cilindros devem sempre ter um furo para drenagem.

DROP - IN

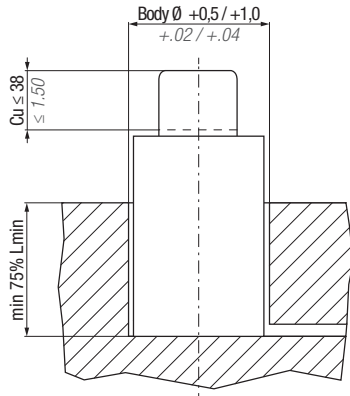

Installation in a flat-end hole.

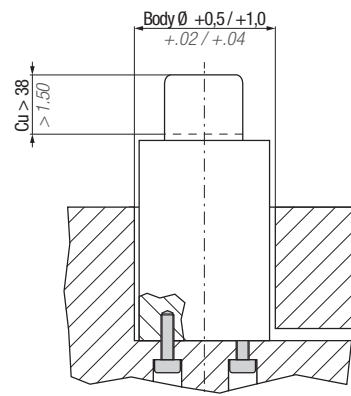

Installation in a flat-end hole with bottom fixing screws.

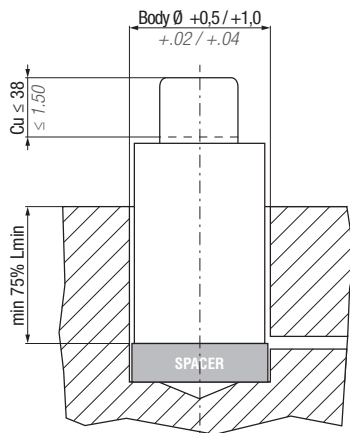

Installation in a flat-end hole with spacer.

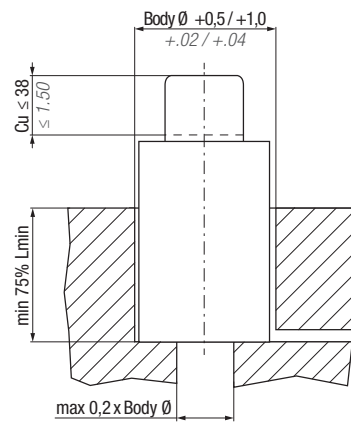

Max throughout bottom hole dimension for drop-in installation.

Esempi di installazione - Installation examples - Montagebeispiele - Exemples d'installation - Ejemplos de instalación - Exemplo de instalação

DROP - IN (NCS, NMC, NT p. 87 - 88)

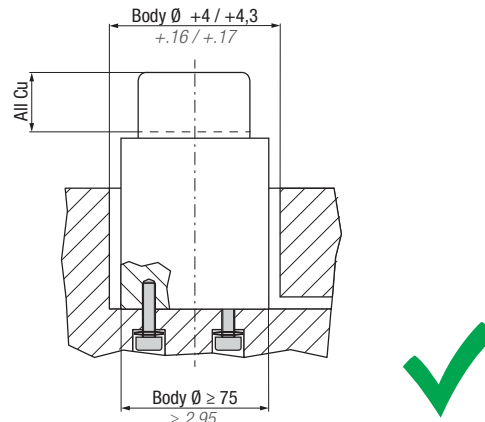
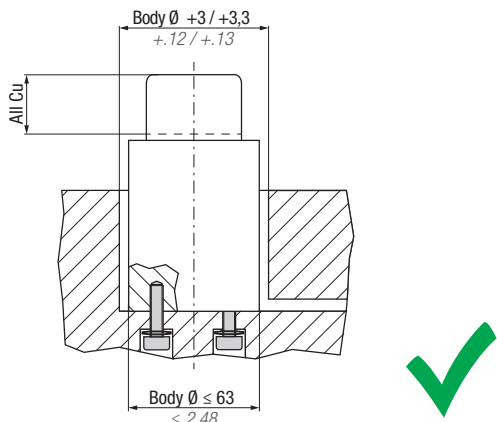

Installation in a flat-end hole with bottom fixing screws.

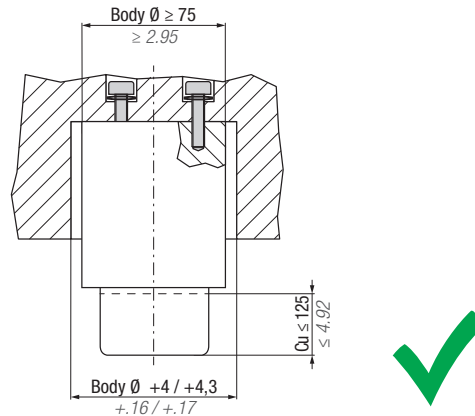
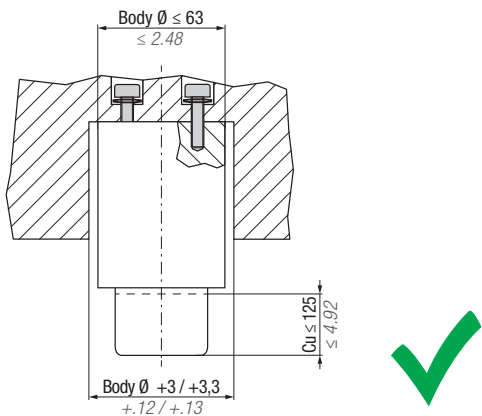

Installation in a flat-end hole with fixing screws in upside down position.

DROP - IN

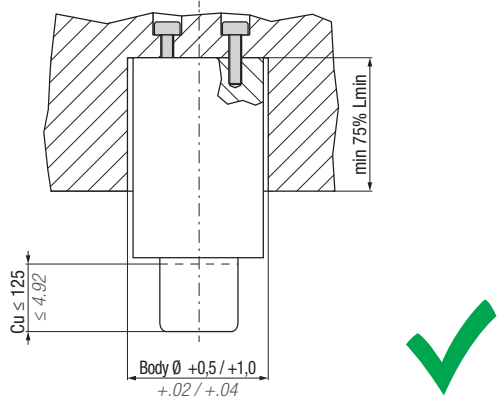

Installation in a flat-end hole with fixing screws in upside down position.

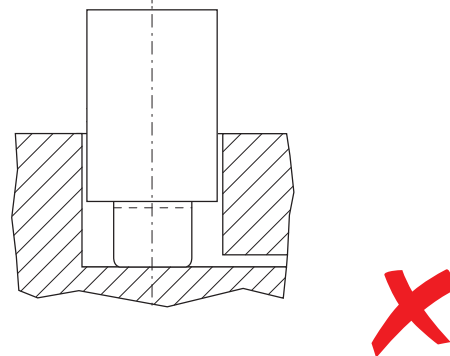

Installation NOT allowed due to excessive body wearing.

Esempi di installazione - Installation examples - Montagebeispiele - Exemples d'installation - Ejemplos de instalación - Exemplo de instalação

BODY THREADED HOLES

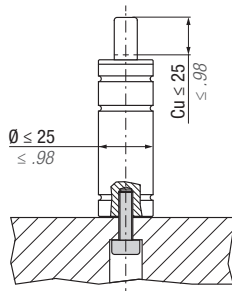

Installation with single fixing screw.

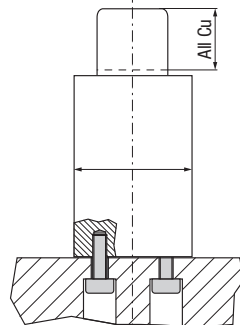

Installation with bottom fixing screws.

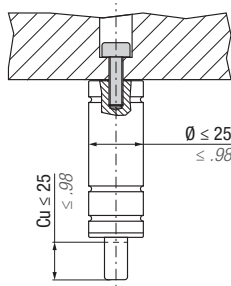
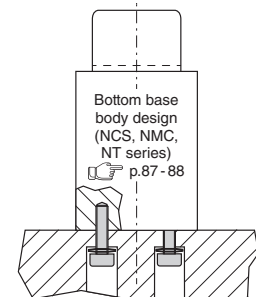

Installation with single fixing screw in upside down position.

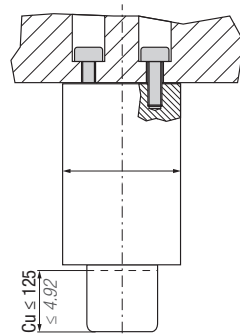

Installation with bottom fixing screws in upside down position.

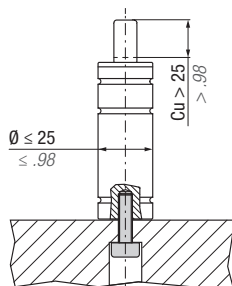
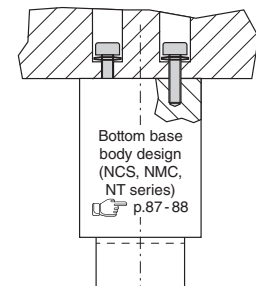

Installation NOT allowed due to excessive stress on gas spring bottom.

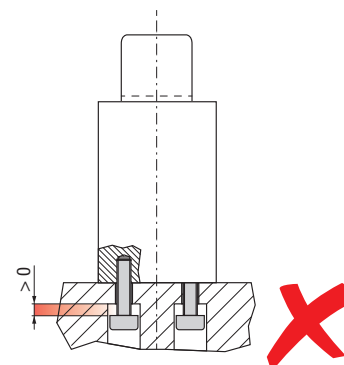
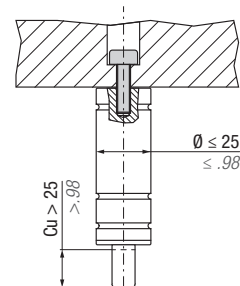

Installation NOT allowed due to incorrect screw length.

Esempi di installazione - Installation examples - Montagebeispiele - Exemples d'installation - Ejemplos de instalación - Exemplo de instalação

FB - FBA - FBB - FBD

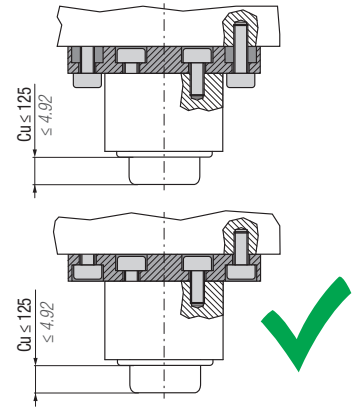
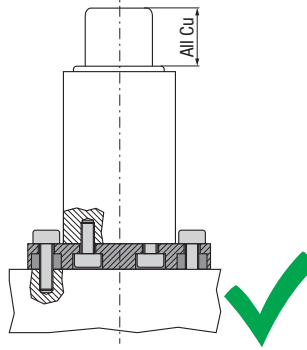
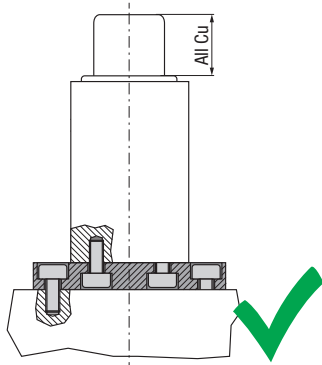

Installation with base flange through fixing screws.

FBE

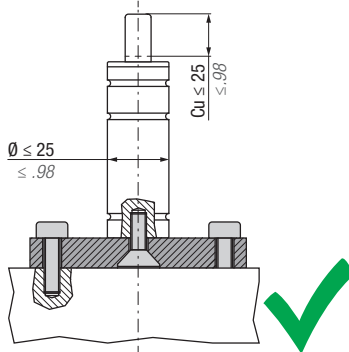

Installation with base flange through single fixing screw.

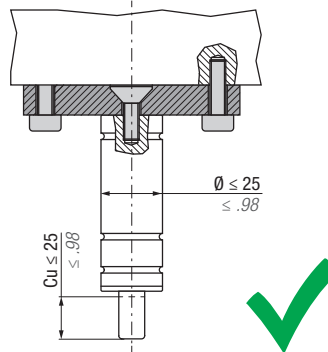

Installation with base flange through single fixing screw in upside down position.

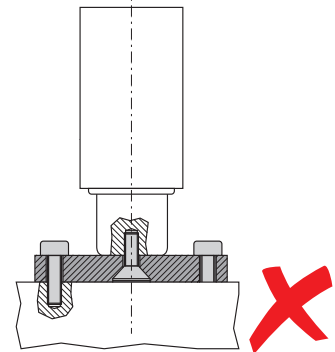

Installation NOT allowed due to excessive stress on screw and internal components.

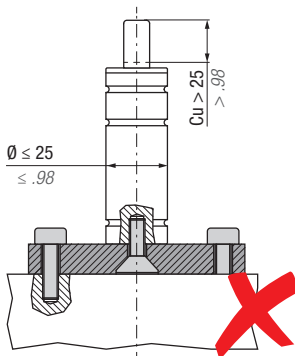

Installation NOT allowed due to excessive stress on gas spring bottom.

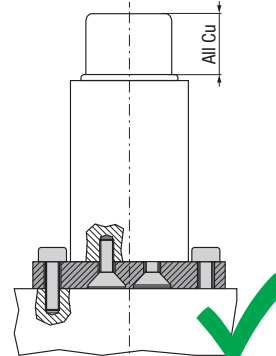
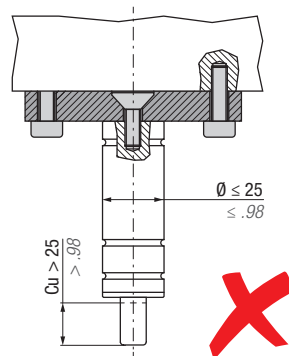

Installation with base flange through fixing screws.

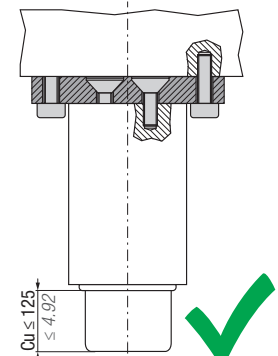

Installation with base flange through fixing screws in upside down position.

All dimensions in mm / inch

INSTALLATION GUIDELINE - TOP MOUNT



Esempi di installazione - Installation examples - Montagebeispiele - Exemples d'installation - Ejemplos de instalación - Exemplo de instalação

FCD - FC - FCC - FCQC

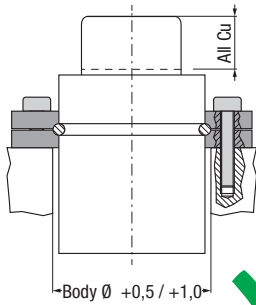

Installation with collar mount flange.

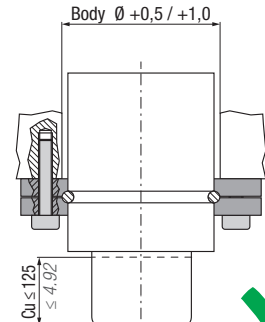
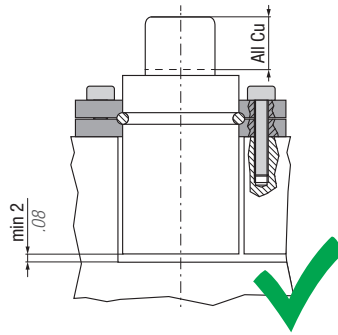

Installation with collar mount flange in upside down position.

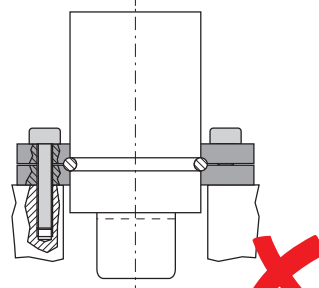
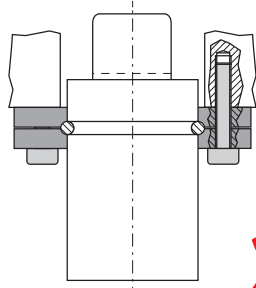

Installation NOT allowed due to tensile stress on screws.

FC (for body gas spring Ø 16 ÷ 25)

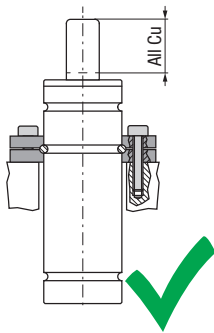

Installation with collar mount flange.

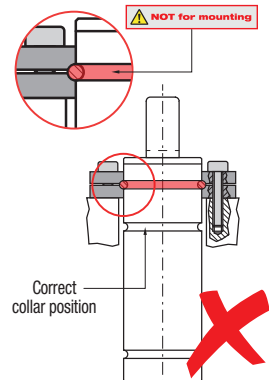
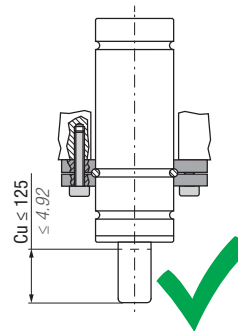
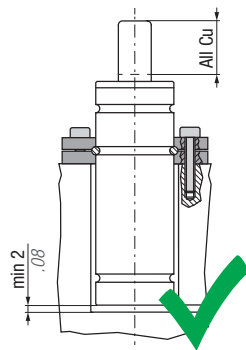

Installation NOT allowed due to excessive stress on internal component (wrong groove).

Esempi di installazione - Installation examples - Montagebeispiele - Exemples d'installation - Ejemplos de instalación - Exemplo de instalação

FC (for body gas spring $\varnothing 16 \div 25$)

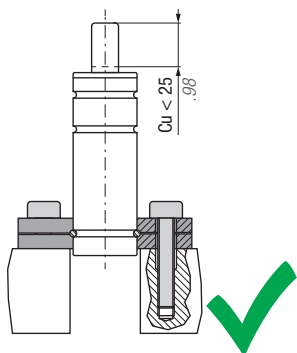

Installation with collar flange on the lower body groove.

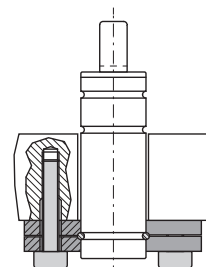
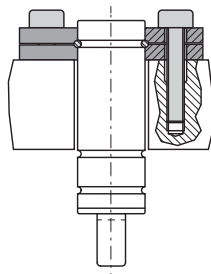

Installation NOT allowed due to tensile stress on screws.

FS3

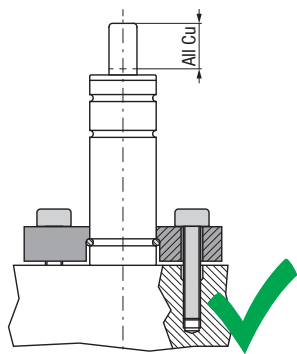

Installation with bracket mount flange.



INSTALLATION GUIDELINE - BODY MOUNT



Esempi di installazione - Installation examples - Montagebeispiele - Exemples d'installation - Ejemplos de instalación - Exemplo de instalação

FSA - FSC - FSD - FSE

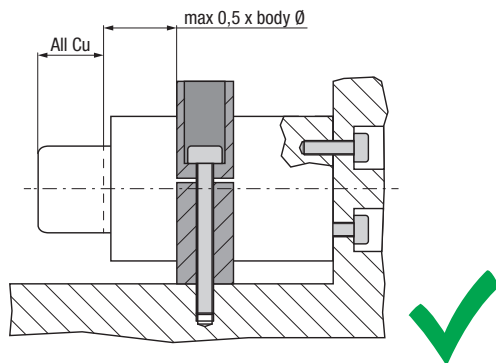

Installation with body mount flange and fixing screws.

(FSA - FSC - FSD - FSE) + R

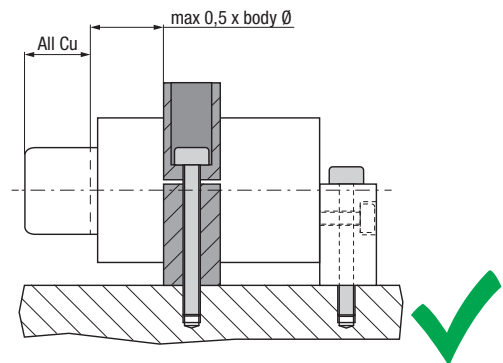

Installation with body mount flange and fixing screws in the rear support.

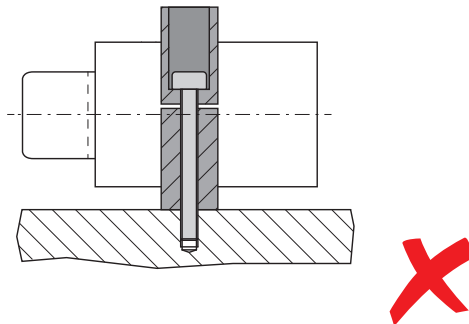

Installation NOT allowed due to lack of reaction force element.

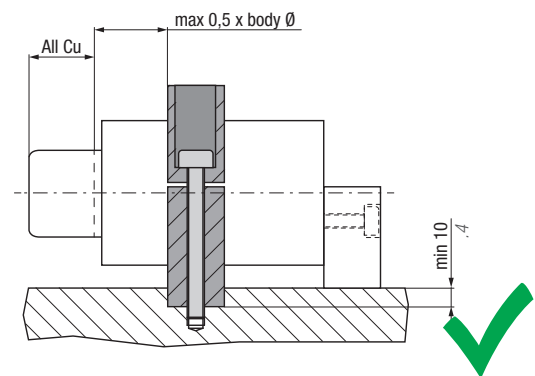

Installation with body mount flange and fixing screws in the rear support.

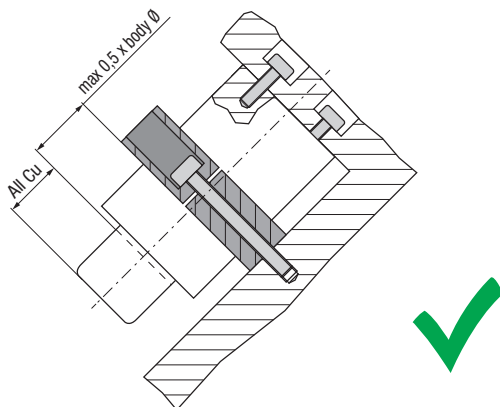

Installation with body mount flange and fixing screws.

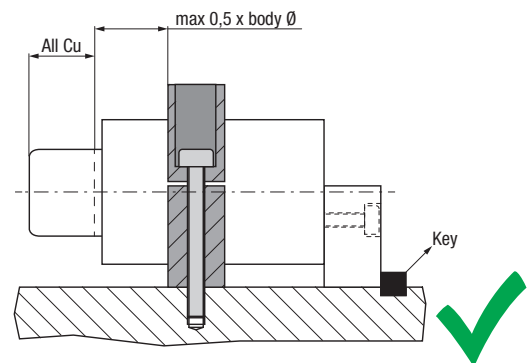

Installation with body mount flange and fixing screws in the key-fixed rear support.

Esempi di installazione - Installation examples - Montagebeispiele - Exemples d'installation - Ejemplos de instalación - Exemplo de instalação

- IT** Installare i cilindri ad azoto rispettando le indicazioni fornite qui sotto. Informazioni dettagliate sono presenti nel kit dedicato.
- EN** Install the gas springs following the directions given here below. Detailed information is included in the specific kit.
- DE** Montieren Sie die Gasdruckfedern gemäß den unten folgenden Anweisungen. Detaillierte Anweisungen finden Sie im jeweiligen Bausatz.
- FR** Installez les ressorts à gaz en suivant les instructions données ci-dessous. Des informations détaillées sont incluses dans le kit spécifique.
- ES** Instale los cilindros de gas siguiendo las instrucciones facilitadas a continuación. Información detallada incluida en el kit correspondiente.
- PT** Fixar os cilindros respeitando as orientações abaixo. Todas as informações detalhadas estão presentes no manual de instruções de cada cilindro.

NCS, NMC, NT series - SELF CONTAINED

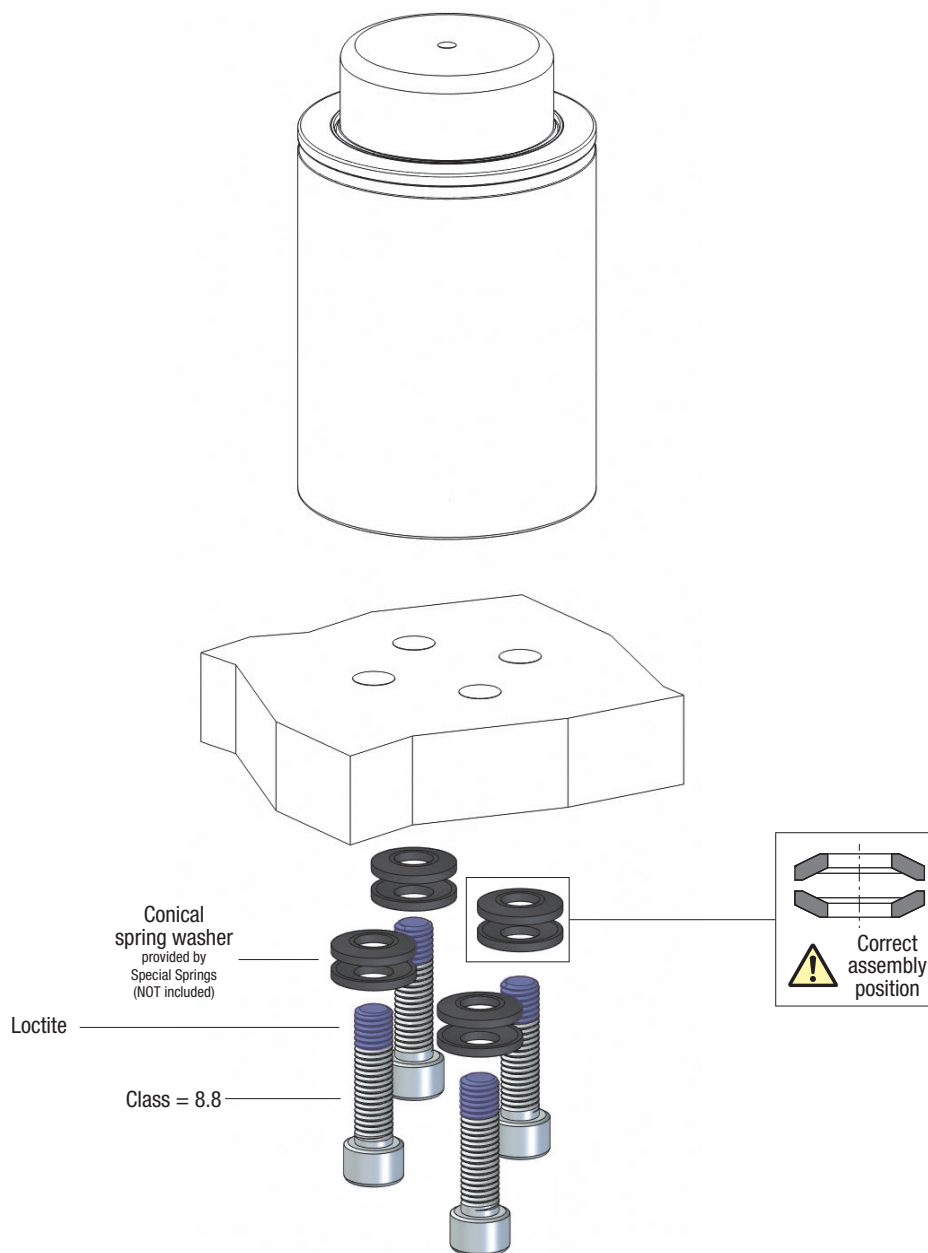

INSTALLATION GUIDELINE (NCS, NMC, NT series)



Esempi di installazione - Installation examples - Montagebeispiele - Exemples d'installation - Ejemplos de instalación - Exemplo de instalação

NCS - EASY MANIFOLD

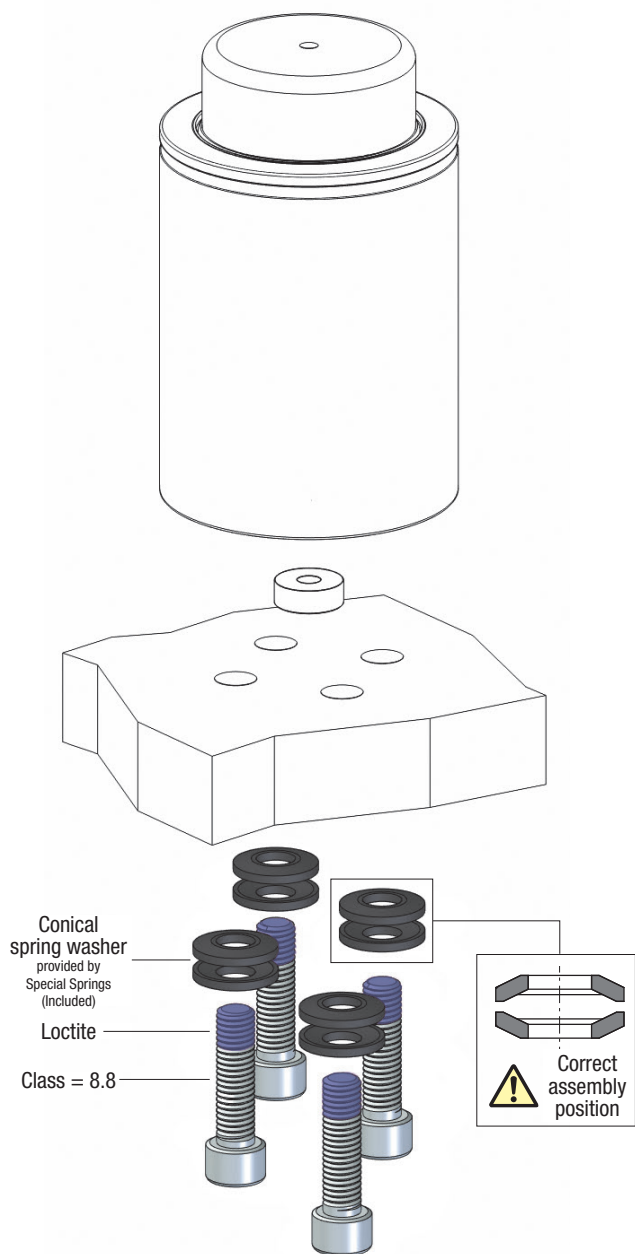

FIXING INFORMATION

- IT** Si raccomanda di installare i cilindri ad azoto nelle versioni "Self Contained" e "Easy Manifold" rispettando le indicazioni qui sotto.
- EN** It is recommended to install gas springs in the "Self-Contained" and "Easy Manifold" versions by following the directions given here below.
- DE** Es wird empfohlen, die Gasdruckfedern der Versionen "Self-Contained" und "Easy Manifold" gemäß den unten aufgeführten Anweisungen einzubauen.
- FR** Il est recommandé d'installer les ressorts à gaz dans les versions "Self-Contained" (autonome) et "Easy Manifold" en suivant les instructions données ci-dessous.
- ES** Se recomienda instalar los cilindros de gas en las versiones "Self-Contained" (autónomo) y "Easy Manifold" siguiendo las instrucciones facilitadas a continuación.
- PT** Se recomenda fixar os cilindros **autonomos** e os para "Easy Manifold", conforme as instruções abaixo.

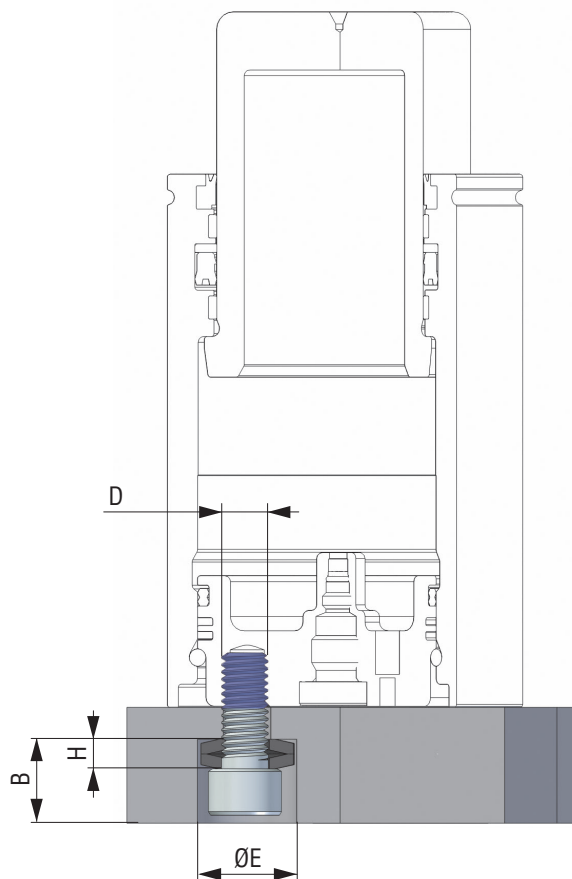

Model	Conical spring washer code	Ø E		B		H		D	UNI EN ISO 21269:2007 class = 8.8
		mm	inch	mm	inch	mm	inch		
NCS 32	49RC06A	≥ 10,25	≥ .40	≥ 9,15	≥ .36	3,15	.12	M6	 UNI EN ISO 21269:2007 class = 8.8
NCS 32.2	49RC06A	≥ 10,25	≥ .40	≥ 9,15	≥ .36	3,15	.12	M6	
NCS 38	49RC06A	≥ 10,25	≥ .40	≥ 9,15	≥ .36	3,15	.12	M6	
NCS 50	49RCHS08A	≥ 17,3	≥ .68	≥ 12	≥ .47	4,00	.16	M8	
NCS 63	49RCHS08A	≥ 17,3	≥ .68	≥ 12	≥ .47	4,00	.16	M8	



THIS PAGE IS INTENTIONALLY LEFT BLANK

FLANGE MOUNTS



IT La seguente tabella indica i riferimenti Special Springs per ogni standards. Vedi esempio sotto riportato.

EN The following table shows the references for each Special Springs standards. See example below.

DE Die folgende Tabelle zeigt die Verweise für jede Special Springs Standards. Siehe Beispiel unten.

FR Le tableau suivant indique les références pour chacune des normes spéciales Springs. Voir l'exemple ci-dessous.

ES La siguiente tabla muestra las equivalencias de cada modelo Special Springs. Ver ejemplo en la parte inferior de esta hoja.

PT A tabela a seguir mostra as referências para cada normas especiais molas. Veja o exemplo abaixo.

Reference to standards	Standards	
0	//	Special Springs
1	ISO 11901-2	
2	VDI 3003	
3	B2 4009	BMW
4	W-DX35-62M	Ford
5	W-DX35-80M	Ford
6	W-DX40-80M	Ford
7	90.25.01	General Motors
8	90.25.02	General Motors
9	90.25.03	General Motors
10	90.25.04	General Motors
11	90.25.06	General Motors
12	90.25.07	General Motors
13	90.25.455	General Motors
14	B8 0132 110 008 801	Mercedes Benz

Reference to standards	Standards	
15	B8 0138 100 000 001	Mercedes Benz
16	B8 0134 300 000 001	Mercedes Benz
17	B8 0134 400 008 801	Mercedes Benz
18	B8	Mercedes Benz
19	E24.54.815.G	Peugeot - Citroën
20	EM24.54.700	Renault
21	39D 848	Volkswagen
22	075.90.70	FCA
23	075.90.75	FCA
24	075.90.80	FCA
25	075.90.85	FCA
26	075.90.90	FCA
27	075.90.95	FCA
28	075.90.40	FCA
29	K32D2-2400-50	Nissan

CODE	Reference to standards	A		B		Ø C		D		Ø E		Ø F		Ø G		Ø H		I		L	
		mm	inch	mm	inch	mm	inch	mm	inch	mm	inch	mm	inch	mm	inch	mm	inch	mm	inch	mm	inch
FB50	1-2-10-19-20	75	2.95	56,5	2.22	20	0.79	20	0.79	15	0.59	15	0.59	9	0.35	9	0.35	14	0.55	12	0.47

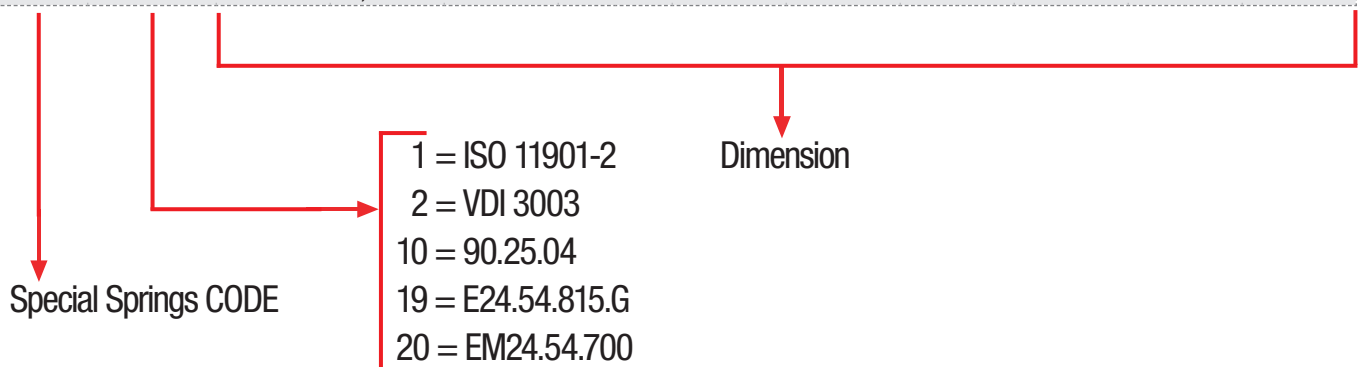

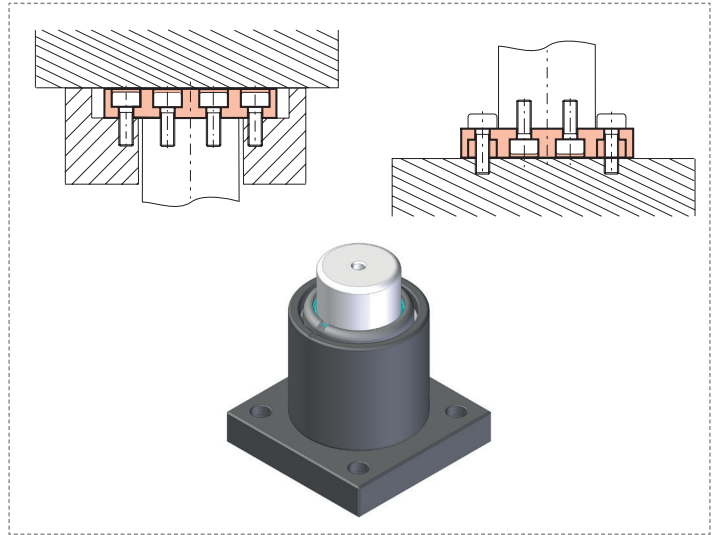
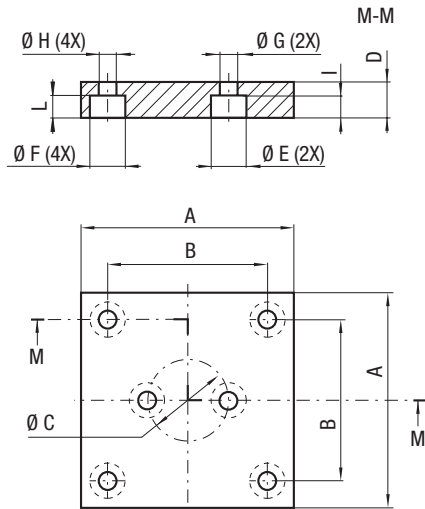

CODE	Reference to standards	A		B		Ø C		D		Ø E		Ø F		Ø G		Ø H		I		L	
		mm	inch	mm	inch	mm	inch	mm	inch	mm	inch	mm	inch	mm	inch	mm	inch	mm	inch	mm	inch
FB 50	1-2-10-19-20	75	2.95	56,5	2.22	20	0.79	20	0.79	15	0.59	15	0.59	9	0.35	9	0.35	14	0.55	12	0.47

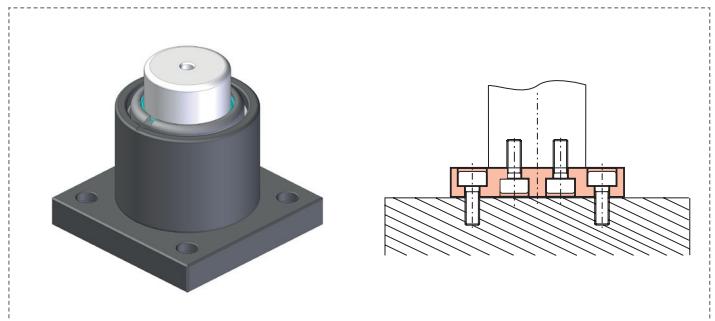
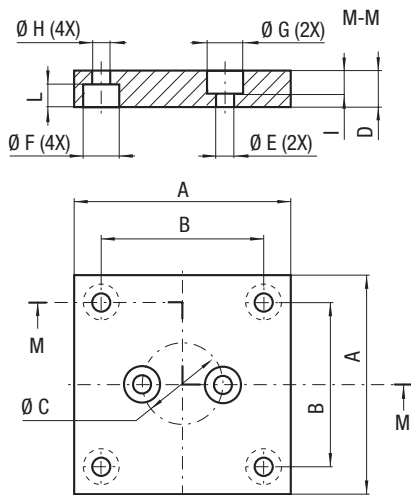

CODE	Reference to standards	A		B		Ø C		D		Ø E		Ø F		Ø G		Ø H		I		L	
		mm	inch	mm	inch	mm	inch	mm	inch	mm	inch	mm	inch	mm	inch	mm	inch	mm	inch	mm	inch
FBA 50	20	75	2.95	56,5	2.22	20	0.79	20	0.79	9	0.35	18	0.71	15	0.59	11	0.43	14	0.55	12	0.47

BMW	Mercedes Benz		

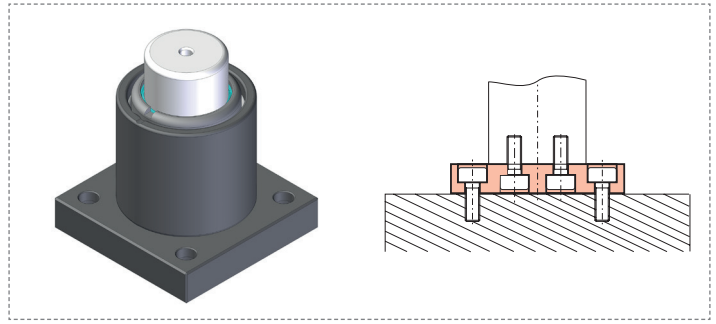
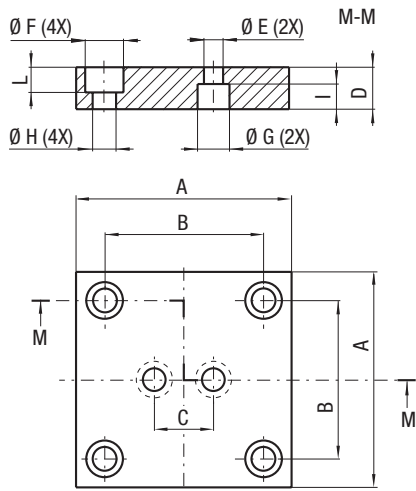

CODE	Reference to standards	A		B		C		D		$\varnothing E$		$\varnothing F$		$\varnothing G$		$\varnothing H$		I		L	
		mm	inch	mm	inch	mm	inch	mm	inch	mm	inch	mm	inch	mm	inch	mm	inch	mm	inch	mm	inch
FBB 50	3-14	75	2.95	56,5	2.22	20	0.79	20	0.79	9	0.35	15	0.59	15	0.59	9	0.35	12	0.47	12	0.47

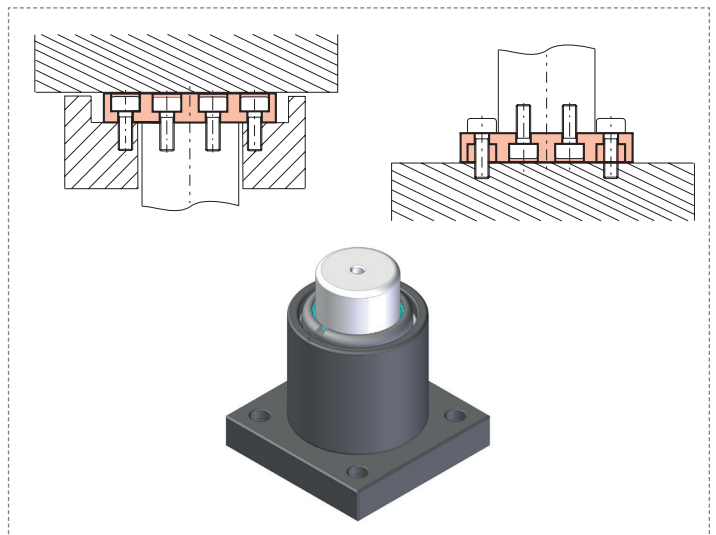
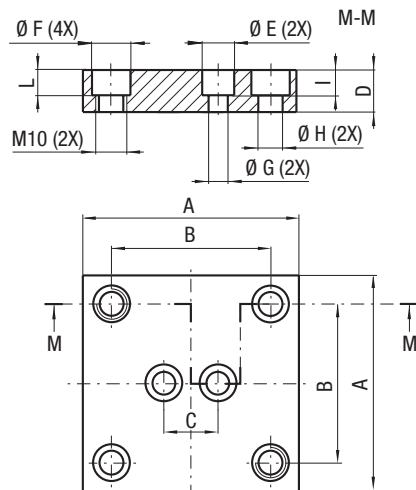

CODE	Reference to standards	A		B		C		D		$\varnothing E$		$\varnothing F$		$\varnothing G$		$\varnothing H$		I		L	
		mm	inch	mm	inch	mm	inch	mm	inch	mm	inch	mm	inch	mm	inch	mm	inch	mm	inch	mm	inch
FBD 50	3	75	2.95	56,5	2.22	20	0.79	20	0.79	15	0.59	15	0.59	9	0.35	9	0.35	12	0.47	12	0.47

M-M

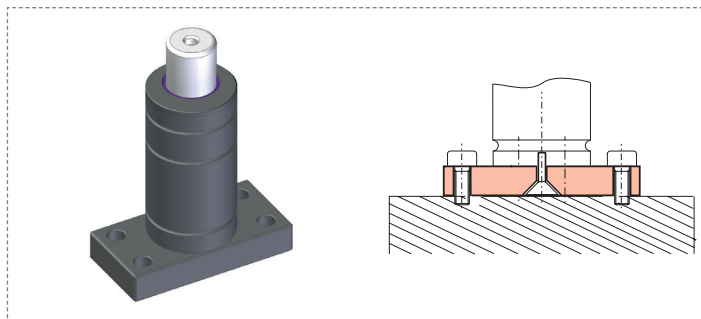
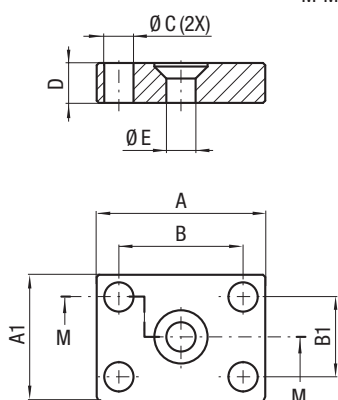

CODE	Reference to standards	A		A1		B		B1		Ø C		D		Ø E	
		mm	inch	mm	inch	mm	inch	mm	inch	mm	inch	mm	inch	mm	inch
FBE 19	0	38	1.50	28	1.10	28	1.10	18	0.71	6,6	0.26	9	0.35	6,6	0.26
FBE 25	0	44	1.73	28	1.10	34	1.34	18	0.71	6,6	0.26	9	0.35	6,6	0.26

M-M

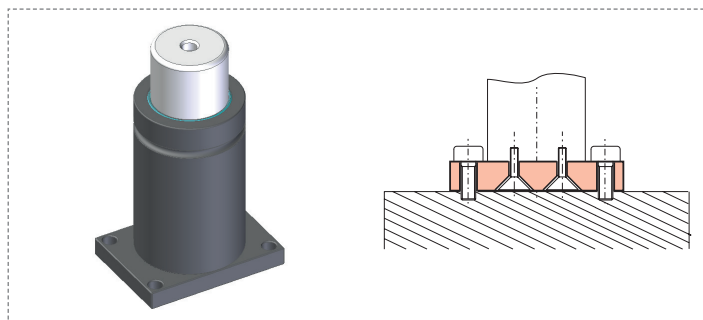
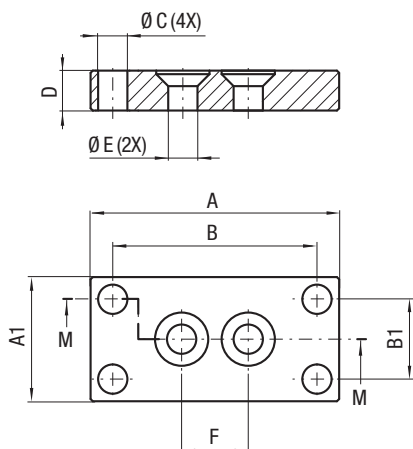

CODE	Reference to standards	A		A1		B		B1		Ø C		D		Ø E		F	
		mm	inch	mm	inch	mm	inch	mm	inch	mm	inch	mm	inch	mm	inch		
FBE 32	0	51	2.01	32	1.26	41	1.61	22	0.87	6.6	0.26	9	0.35	6,6	0.26	15	0.59
FBE 38	0	57	2.24	38	1.50	47	1.85	28	1.10	6.6	0.26	9	0.35	6,6	0.26	20	0.79
FBE 50	0	69	2.72	50	1.97	59	2.32	40	1.57	6.6	0.26	9	0.35	9	0.35	20	0.79
FBE 63	0	84	3.31	65	2.56	70	2.76	50	1.97	6.6	0.26	9	0.35	9	0.35	20	0.79

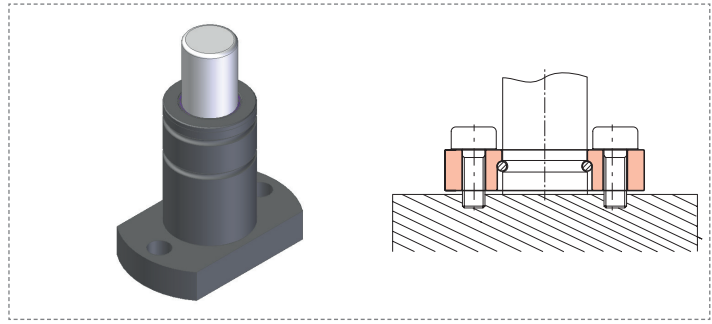
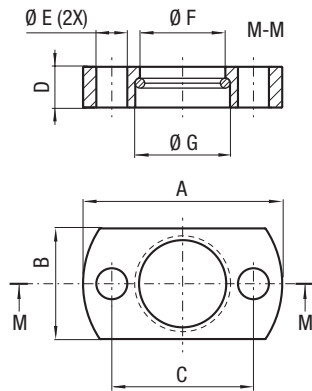

CODE	Reference to standards	A		B		C		D		Ø E		Ø F		Ø G	
		mm	inch	mm	inch	mm	inch	mm	inch	mm	inch	mm	inch	mm	inch
FS3 19	0	45	1.77	25	0.98	32	1.26	9,2	0.36	7	0.28	19,3	0.76	21,4	0.84
FS3 25	0	50	1.97	30	1.18	38	1.50	9,2	0.36	7	0.28	25,3	1.00	27,4	1.08

FCD

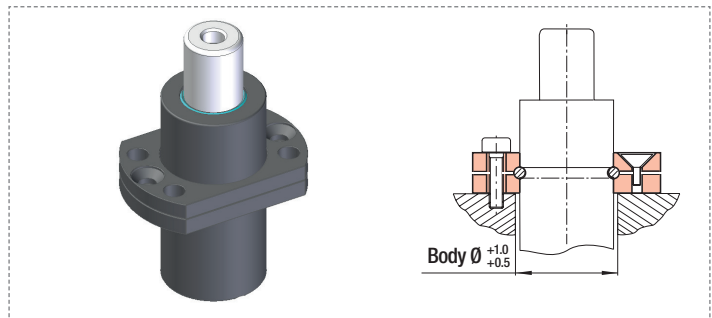
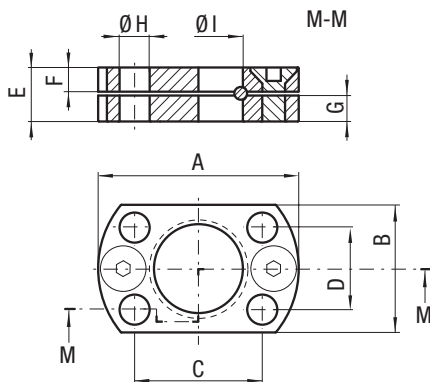

CODE	Reference to standards	A		B		C		D		E		F		G		Ø H		Ø I	
		mm	inch	mm	inch	mm	inch	mm	inch	mm	inch	mm	inch	mm	inch	mm	inch	mm	inch
FCD 19	0	44	1.73	28	1.10	28	1.10	18	0.71	11	0.43	5,2	0.20	5,6	0.22	6,6	0.26	19,5	0.77
FCD 25	0	50	1.97	30	1.18	34	1.34	18	0.71	11	0.43	5,2	0.20	5,6	0.22	6,6	0.26	25,5	1.00
FCD 32	0	57	2.24	39	1.54	40	1.57	22	0.87	11	0.43	5,2	0.20	5,6	0.22	6,6	0.26	32,5	1.28
FCD 38	0	63	2.48	46	1.81	45	1.77	26	1.02	11	0.43	5,2	0.20	5,6	0.22	6,6	0.26	38,5	1.52
FCD 50	0	75	2.95	58	2.28	54	2.13	34	1.34	11	0.43	6,2	0.24	4,6	0.18	6,6	0.26	50,5	1.99
FCD 63	0	98	3.86	76	2.99	74	2.91	40	1.57	13	0.51	8,9	0.35	3,9	0.15	9	0.35	63,5	2.50

Fig. 1

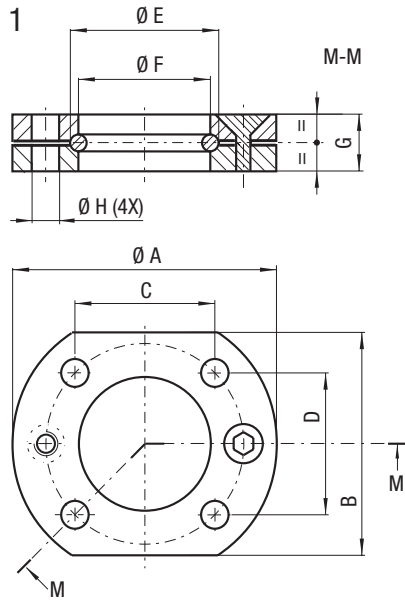
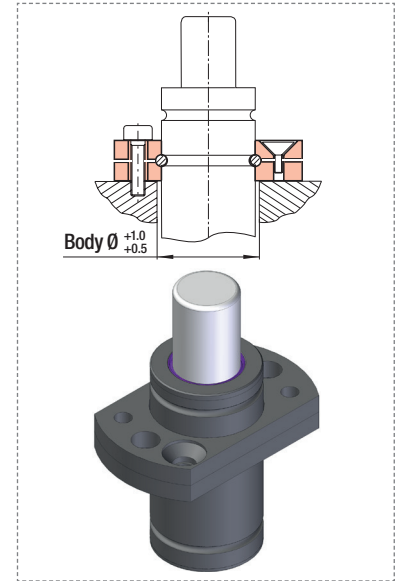
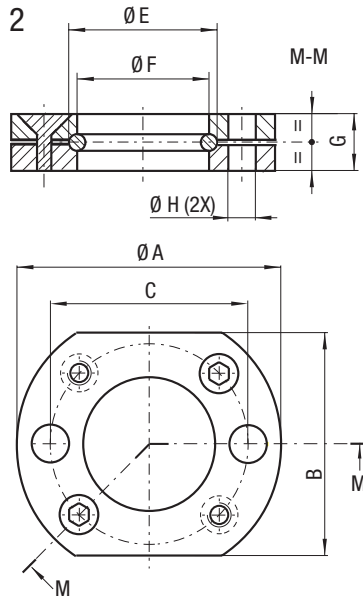
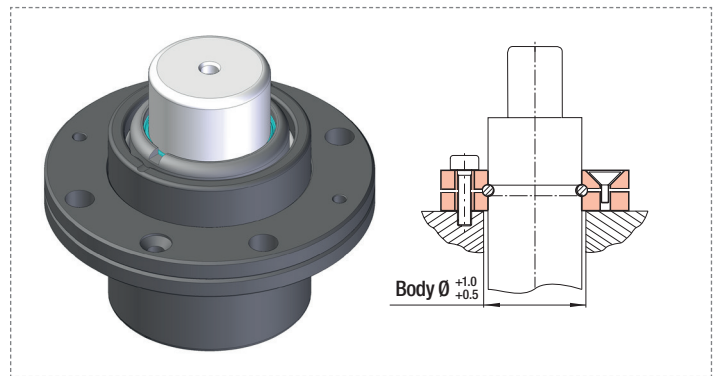
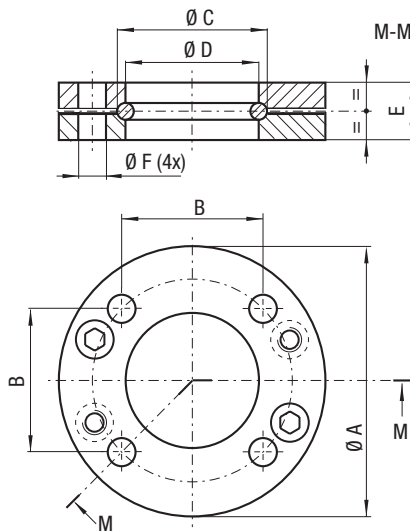

Fig. 2



CODE	Reference to standards	Ø A		B		C		D		Ø E		Ø F		G		Ø H		Rif. Fig
		mm	inch	mm	inch	mm	inch	mm	inch	mm	inch	mm	inch	mm	inch	mm	inch	
FC 19 B	1-5	44	1.73	25	0.98	30	1.18	12	0.47	21,9	0.86	19,5	0.77	9	0.35	6,6	0.26	Fig. 1
FC 25 B	1-5	50	1.97	30	1.18	34	1.34	18	0.71	27,9	1.10	25,5	1.00	9	0.35	6,6	0.26	
FCC 19 A	2-3-17-21-23	44	1.73	25	0.98	32	1.26	-	-	21	0.83	19,5	0.77	9	0.35	6,6	0.26	
FCC 25 A	2-3-17-19-21-23	50	1.97	30	1.18	38	1.50	-	-	27	1.06	25,5	1.00	9	0.35	6,6	0.26	Fig. 2



CODE	Reference to standards	Ø A		B		Ø C		Ø D		E		Ø F	
		mm	inch	mm	inch	mm	inch	mm	inch	mm	inch	mm	inch
FC32A	1-9-16-24	60	2.36	35	1.38	34	1.34	32,5	1.28	9	0.35	7	0.28
FC38A	1-9-16-24	68	2.68	40	1.57	40	1.57	38,5	1.52	9	0.35	7	0.28
FC50A	1-9-16-24	95	3.74	56,5	2.22	54	2.13	50,5	1.99	13	0.51	9	0.35

ISO	VDI	BMW	General Motors
Volkswagen			

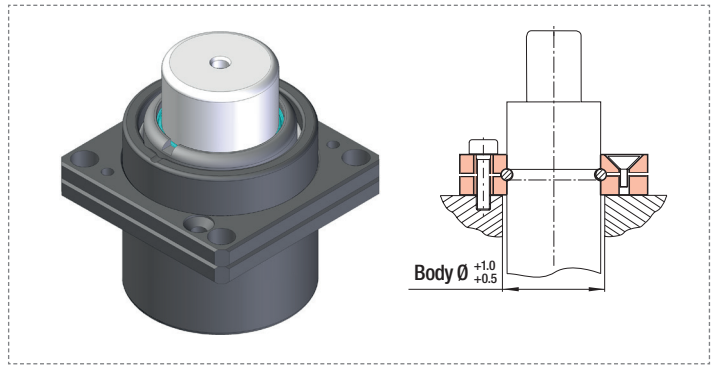
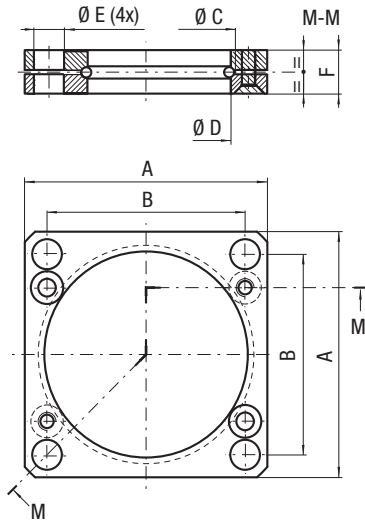

CODE	Reference to standards	A		B		Ø C		Ø D		Ø E		F	
		mm	inch	mm	inch	mm	inch	mm	inch	mm	inch	mm	inch
FCQC 32	2-8-25	45	1.77	35	1.38	34	1.34	32,5	1.28	7	0.28	9	0.26
FCQC 38	1-2-3-8-25	52	2.05	40	1.57	40	1.57	38,5	1.52	7	0.28	9	0.35
FCQC 50	1-2-3-8-25	70	2.76	56,5	2.22	54	2.13	50,5	1.99	9	0.35	13	0.51
FCQC 63	2-21	80	3.15	64	2.52	67	2.64	63,45	2.50	11	0.43	16	0.63

ISO	General Motors		
-----	----------------	--	--

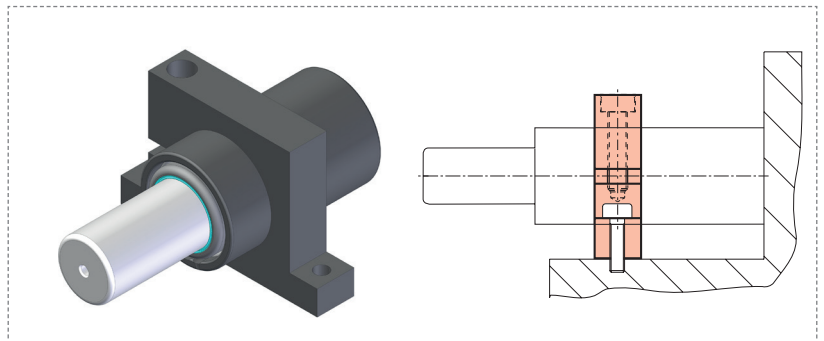
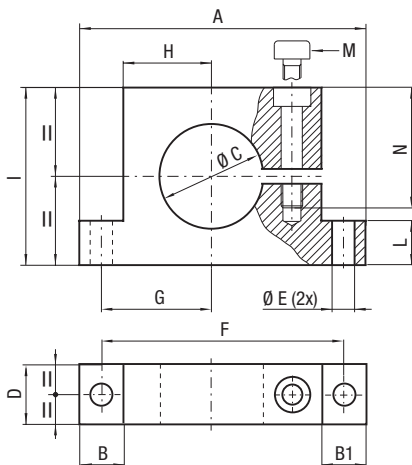

CODE	Reference to standards	A		B		B1		Ø C		D		Ø E		F		G		H		I		L		M		N	
		mm	inch	mm	inch	mm	inch	mm	inch	mm	inch	mm	inch	mm	inch	mm	inch	mm	inch	mm	inch	mm	inch	mm	inch	mm	inch
FSA 32	1-13-19	90	3.54	18	0.71	18	0.71	32	1.26	20	0.79	9	0.35	72	2.83	31	1.22	22	0.87	45	1.77	15	0.59	M8	39	1.54	
FSA 38	1-13-19	95	3.74	18	0.71	18	0.71	38	1.50	20	0.79	9	0.35	77	3.03	34	1.34	25	0.98	55	2.17	15	0.59	M8	45	1.77	
FSA 50	1-13-19	130	5.12	20	0.79	20	0.79	50	1.97	30	1.18	9	0.35	110	4.33	50	1.97	40	1.57	80	3.15	20	0.79	M8	55	2.17	

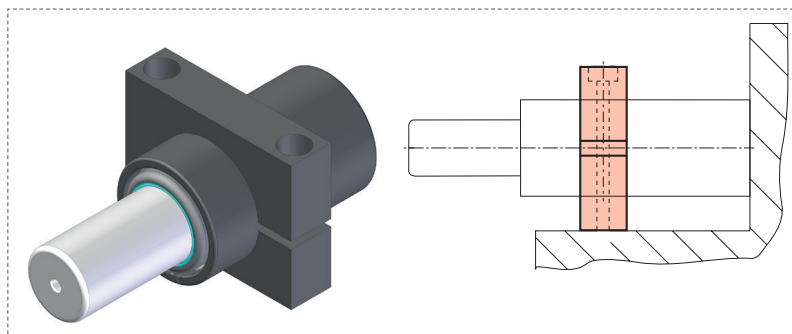
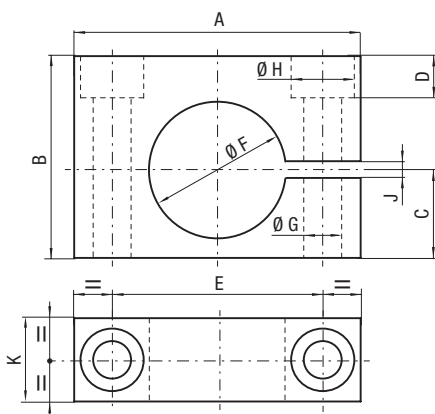

CODE	Reference to standards	A		B		C		D		E		Ø F		Ø G		Ø H		J		K	
		mm	inch	mm	inch	mm	inch	mm	inch	mm	inch	mm	inch	mm	inch	mm	inch	mm	inch	mm	inch
FSD 32	2-3-12-18-21-27	68	2.68	48	1.89	20,9	0.82	10	0.39	50	1.97	32,5	1.28	9	0.35	15	0.59	4	0.16	20	0.79
FSD 38	2-3-12-18-21-27	74	2.91	54	2.13	23,9	0.94	16	0.63	54	2.13	38,5	1.52	9	0.35	15	0.59	4	0.16	20	0.79
FSD 50	2-3-12-18-21-27	90	3.54	70	2.76	30	1.18	25	0.98	68	2.68	50,5	1.99	11	0.43	18	0.71	5	0.20	30	1.18
FSC 63	0	105	4.13	80	3.15	40	1.57	11	0.43	80	3.15	63	2.48	10,5	0.41	17	0.67	10	0.39	30	1.18
FSD 63	2-18-21-27	108	4.25	82	3.23	36,5	1.44	27	1.06	84	3.31	63,5	2.50	11	0.43	18	0.71	5	0.20	30	1.18

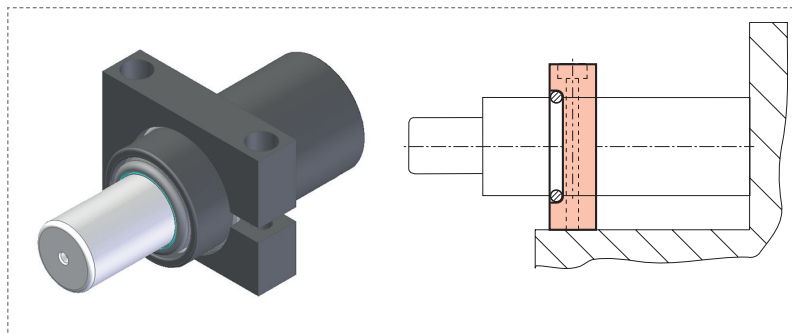
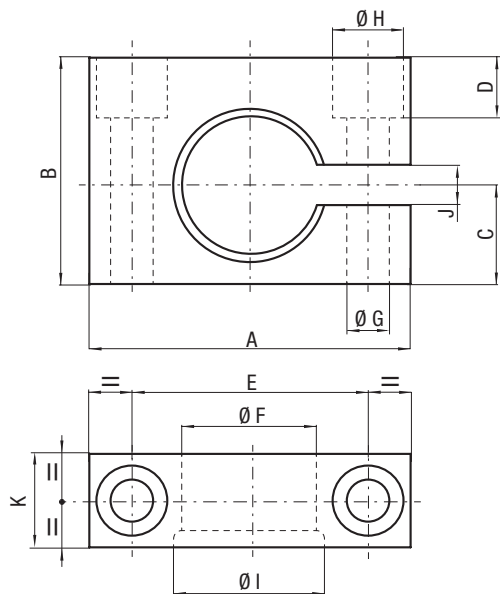

CODE	Reference to standards	A		B		C		D		E		Ø F		Ø G		Ø H		Ø I		J		K	
		mm	inch	mm	inch	mm	inch	mm	inch	mm	inch	mm	inch	mm	inch	mm	inch	mm	inch	mm	inch	mm	inch
FSE 50	11	90	3.54	70	2.76	30	1.18	25	0.98	68	2.68	50,3	1.98	11	0.43	18	0.71	54,1	2.13	10	0.39	30	1.18

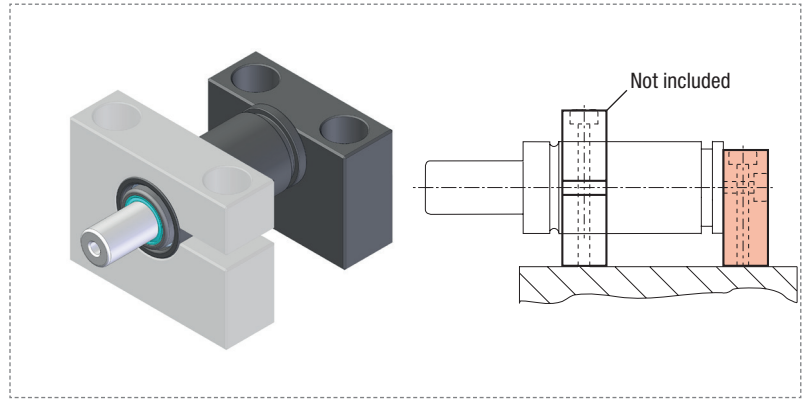
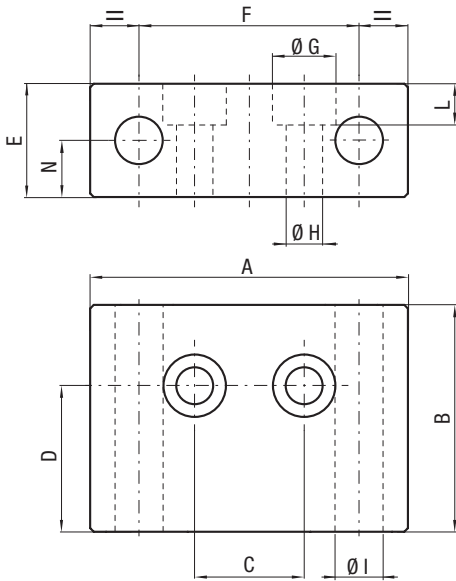

CODE	Reference to standards	A		B		C		D		E		F		ØG		ØH		L		ØI		N	
		mm	inch	mm	inch	mm	inch	mm	inch	mm	inch	mm	inch	mm	inch	mm	inch	mm	inch	mm	inch	mm	inch
R50A	11	65	2.56	45	1.77	20	0.79	30	1.18	28	1.10	44	1.73	14	0.55	9	0.35	10	0.39	11	0.43	13	0.51

THIS PAGE IS INTENTIONALLY LEFT BLANK

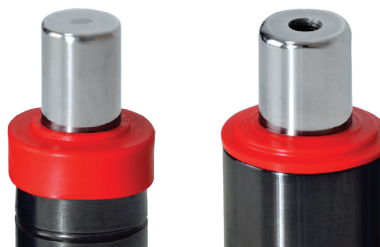

IT Special Springs offre una completa gamma di raschiatori secondari per migliorare le prestazioni dei cilindri ad azoto utilizzati in ambienti molto contaminati.

I nuovi raschiatori secondari in poliuretano sono progettati per un perfetto fitting con i vari modelli di cilindri. Vedi le tabelle per i dati tecnici. I raschiatori secondari sono ordinabili separatamente dal cilindro ad azoto e installabili dall'utilizzatore o, se richiesti al momento dell'ordine, installati direttamente in fabbrica da Special Springs.

EN Special Springs offers a complete range of secondary wipers to improve performances of gas springs used in heavy contaminated environments.

The new secondary wipers, made in polyurethane, are designed for a perfect fitting with many series of gas springs. See the charts for technical data.

The secondary wipers can be ordered separately from the gas springs. They can be assembled by user or, if requested with the order, by Special Springs.

DE Bietet Special Springs ein komplettes Sortiment an Sekundärabstreifer zur Verbesserung der Leistungen von Gasdruckfedern, die in stark kontaminierten Umgebungen eingesetzt werden.

Die neuen Sekundärabstreifer, hergestellt aus Polyurethan, sind für eine perfekte Montage mit vielen Serien von Gasdruckfedern ausgelegt. Siehe die Tabelle für technische Daten.

Die Sekundärabstreifer können separat von den Gasdruckfedern bestellt und vom Anwender montiert werden oder, falls in der Bestellung gewünscht, werkseitig vormontiert von Special Springs.

FR Special Springs offre une gamme complète de joints racleurs secondaires pour améliorer les performances des ressorts à gaz utilisés dans les environnements fortement contaminés.

Les nouveaux joints racleurs secondaires, fabriqués en polyuréthane, sont conçus pour une parfaite fixation avec de nombreuses séries de ressorts à gaz. Voir les tableaux pour les données techniques.

Les joints racleurs secondaires peuvent être commandés séparément des cylindres et assemblés par l'utilisateur ou, si demandé dans la commande, seront assemblés en usine par Special Springs.

ES Special Springs ofrece una gama completa de rascadores secundarios para mejorar las prestaciones de los cilindros de nitrógeno en caso de uso en entornos especialmente contaminados.

Los nuevos rascadores secundarios de poliuretano están diseñados para un ajuste perfecto con varios modelos de cilindros de nitrógeno. Consulte las tablas para obtener información técnica.

Los rascadores secundarios se pueden pedir por separado y ser montados por el usuario o, si se solicita en el pedido, se montarán en fábrica por Special Springs.

PT Special Springs oferece uma gama completa de raspadores secundários para melhorar os desempenhos dos cilindros de nitrogênio utilizados em ambientes muito contaminados.

Os novos raspadores secundários, feitos de poliuretano, são projetados para um perfeito montagem com muitas séries de cilindros de nitrogênio. Veja a guia abaixo para obter dados técnicos.

Os raspadores secundários podem ser encomendados separadamente dos cilindros e montados pelo usuário ou, se solicitado com a ordem, serão montados na fábrica por Special Springs.

Gas spring Code	A mm	B mm	Secondary Wiper Code
NML / NC / NMX 32	2	4	59SW041
NML / NC / NMX 38	2	4	59SW042
NML / NMX 50	2	4	59SW081
NML 63	2,5	4,5	59SW084
NML 75	2,5	4,5	59SW085

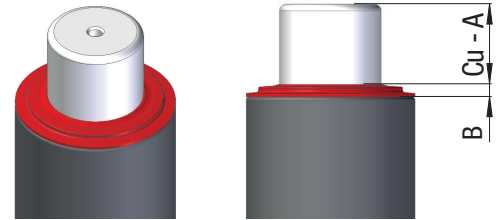

A = Nominal stroke reduction

Cu = Nominal Stroke

 The installation of the secondary wiper requires the removal of the active safety marker OSM where mounted.

Gas spring Code	A mm	B mm	Ø D mm	Secondary Wiper Code
NCS / NMC / NMX / NMS 19	1,5	9,5	22	59SW083
NCS	1,5	30	29	59SW079
NCS / NT 32	1,5	33	36	59SW043
NCS 32.2	1,5	33	36	59SW077
NCS 38	1,5	19	42	59SW044
NCS 50	0,5	21	54	59SW061
NCS 63	0,5	21	67	59SW082
NML 25	1,5	9,5	28	59SW086
NMS 19	1,5	9,5	22	59SW083
NMS 25	1,5	9,5	28	59SW028
NMX 25 GR / BU / RD / YW	1,5	9,8	28	59SW080

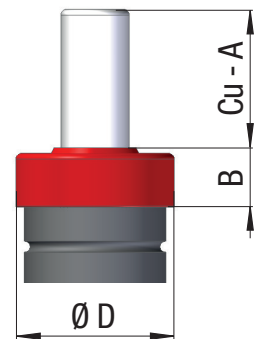
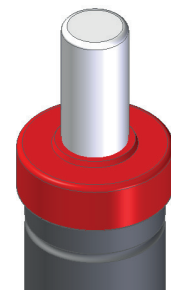

A = Nominal stroke reduction

Cu = Nominal Stroke

HOW TO ORDER

E.g. How to order a gas spring with Secondary Wiper **already installed**

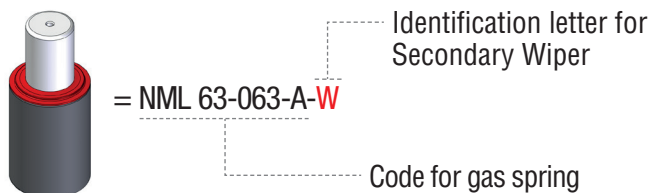

E.g. How to order **only** the Secondary Wiper

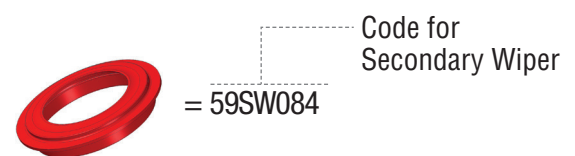

THIS PAGE IS INTENTIONALLY LEFT BLANK

the easy way
to link gas springs through plate



OSAS
Over Stroke
Active Safety



USAS
Uncontrolled Speed
Active Safety



OPAS
Over Pressure
Active Safety



SKUDO
Active Protection
from Contaminants

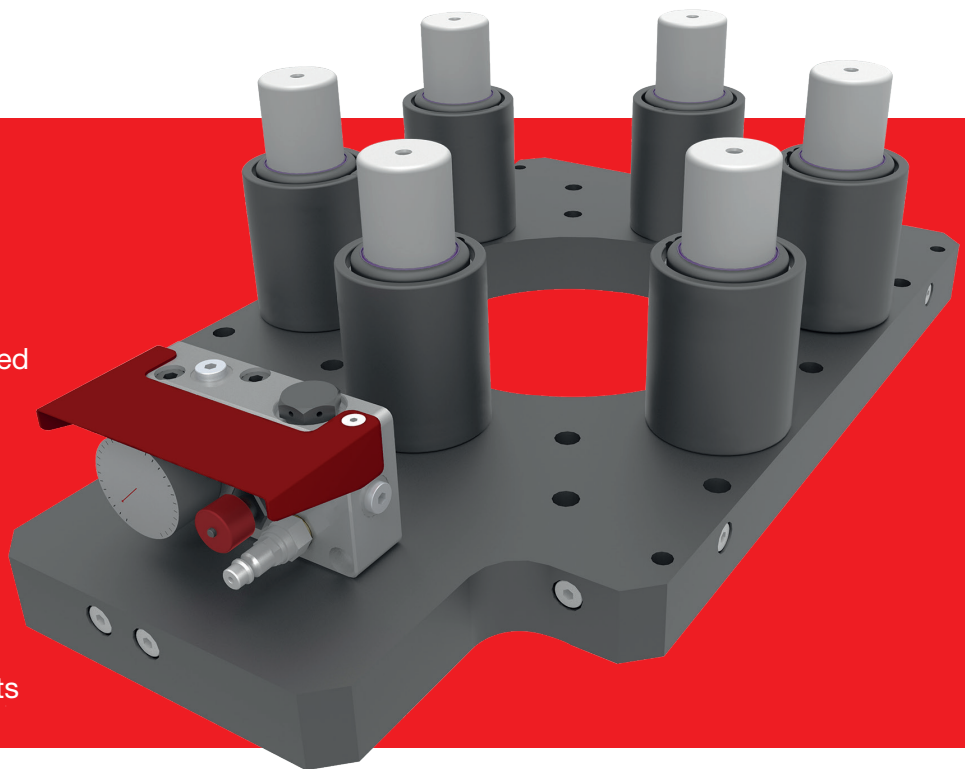

E versions

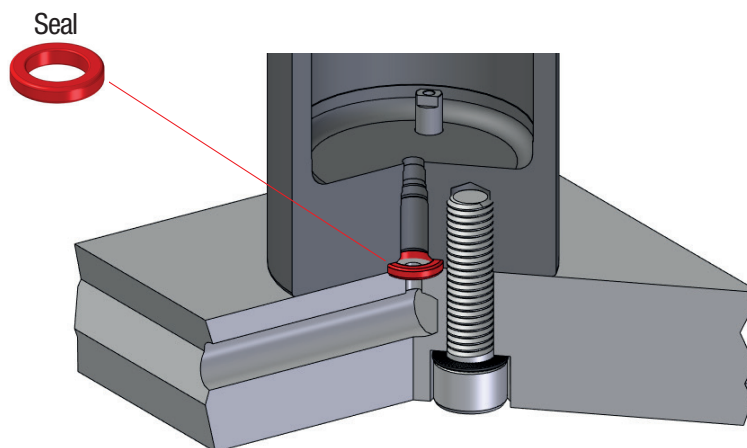

IT CARATTERISTICHE:

- Vantaggiosa alternativa ai tradizionali e costosi cilindri Manifold.
- Grande varietà di combinazioni con l'uso di cilindri standard.
- Totale eliminazione di tubi e raccordi.
- Pressione uniforme nel sistema.
- Facile manutenzione, uguale ai cilindri standard.
- Piastre di collegamento realizzabili direttamente dagli utilizzatori.
- Massima flessibilità di realizzazione degli impianti.
- Nessuna richiesta di utensili speciali per l'installazione.
- **Special Springs è in grado di fornire le piastre/cuscino su specifiche del cliente, collaudate e pronte per l'installazione.**

EN CHARACTERISTICS:

- An advantageous alternative to conventional and expensive Manifold cylinders.
- Large variety of combinations with the use of standard gas springs.
- Total elimination of hoses and connections.
- Balanced pressure in the system.
- Easy maintenance, the same as standard gas springs.
- Connection plates can be made directly by users.
- Maximum flexibility in creation of systems.
- No special tools required for installation.
- **Special Springs can supply the plates/cushion to customer specifications, tested and ready for installation.**

FR CARACTERISTIQUES:

- Une alternative avantageuse aux traditionnels et coûteux cylindres Manifold.
- Une grande variété de combinaisons avec l'emploi de cylindres standard.
- L'élimination totale de tuyaux et raccords.
- Pression uniforme dans le système.
- Entretien facile, comme celui des cylindres standard.
- Plaques de liaison réalisables directement par les utilisateurs.
- Très grande souplesse de réalisation des installations.
- Aucun besoin d'outils spéciaux pour l'installation.
- **Special Springs est en mesure de fournir les plaques/coussin sur spécifications du client, testées et prêtes à être installées.**

ES CARACTERÍSTICAS:

- Ventajosa alternativa a los tradicionales y costosos cilindros Manifold.
- Gran variedad de combinaciones con el uso de cilindros (autónomos) estándar.
- Total eliminación de tubos y racores.
- Presión uniforme en el sistema.
- Fácil mantenimiento, igual a la de los cilindros (autónomos) estándar.
- Placas de conexión producibles directamente por el usuario.
- Máxima flexibilidad de diseño de los sistemas de conexión.
- No se requiere ninguna herramienta especial para la instalación.
- **Special Springs puede proporcionar las placas/cojines según especificaciones del cliente, comprobados y listos para la instalación.**

DE EIGENSCHAFTEN

- Preisgünstige Alternative zu herkömmlichen Manifold-Gasdruckfedern.
- Große Auswahl an Einsatzkombinationen durch Verwendung von Standardzylindern.
- Keine Verwendung von Schläuchen und Anschlüssen.
- Gleichmäßiger Druck im System.
- Wartungsfreundlich.
- Verbundplatten können vom Kunden selbst gefertigt werden.
- Hohe Flexibilität bei den Anwendungen.
- Montage ohne Sonderwerkzeuge.
- **Platten können von Special Springs gefertigt, getestet und vormontiert geliefert werden.**

PT CARACTERÍSTICAS:

- Vantajosa alternativa aos tradicionais e caros cilindros Manifold.
- Grande variedade de combinações com uso de cilindros standard.
- Total eliminação de tubos e junções.
- Pressão uniforme em o sistema.
- Fácil manutenção, igual a dos cilindros standard.
- Chapas de conexão que podem ser realizadas diretamente pelos usuários.
- Máxima flexibilidade de realização das instalações.
- Não é necessário utilizar nenhum tipo de utensílio especial para a instalação.
- **Special Springs pode fornecer chapas/coxim conforme exigência do cliente, testadas e verificadas prontas para a instalação.**

Design recommendations

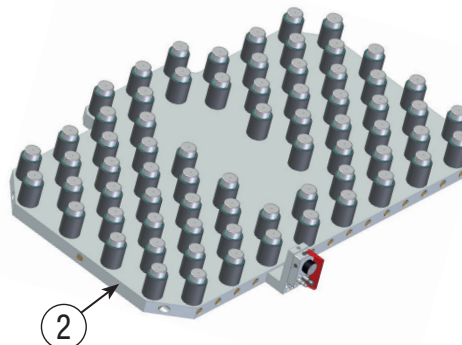
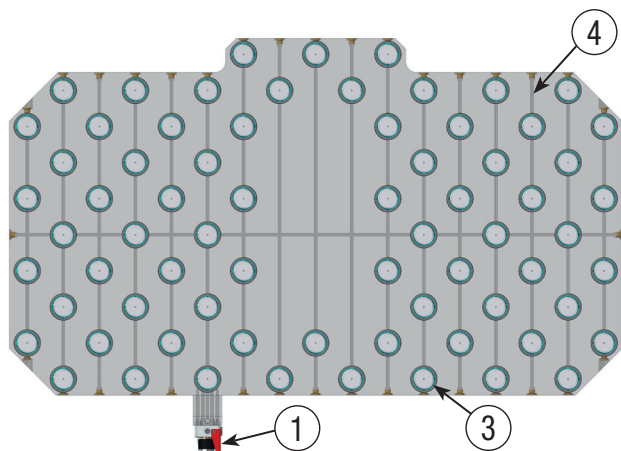

IT Per una facile progettazione e per ridurre i costi di produzione seguire le linee guida di cui sotto

- ① • Per collegare il pannello usare, se possibile, i canali del gas esistenti.
• In alternativa collegare il pannello con tubi e raccordi.
- ② • Resilienza materiale piastra alla temperatura minima di utilizzo $\geq 27\text{J}$.
• Allungamento a rottura del materiale piastra $\geq 14\%$.
- ③ • Evitare interferenza tra i fori di fissaggio dei cilindri e i canali del gas.
• Selezionare cilindri con corse maggiori per aumentare il volume del sistema.
- ④ • Realizzare canali passanti e pulire adeguatamente.
• Evitare canali ciechi.

EN For easier design and manufacturing cost-saving follow the guide lines below

- ① • When possible, use the existing gas ports to link the panel.
• Alternatively, link the panel by using hoses and connections.
- ② • Resilience of the plate material at minimum operating temperature $\geq 27\text{J}$.
• Elongation at break of plate material $\geq 14\%$.
- ③ • Avoid interference between the gas spring's fixing holes and the gas ports.
• Select gas springs with higher stroke to increase the volume of the system.
- ④ • Machine thru-holes and adequately clear the ports.
• Avoid blind channels.

DE Für eine leichter von staten gehende Entwicklung und um Produktionskosten zu sparen, befolgen Sie die Richtlinien unten.

- ① • Die Kontrollarmatur, wenn möglich, an den vorhandenen Tieflochbohrungen anbringen.
• Alternativ kann die Druckkontrollarmatur mit Schlauchkomponenten angeschlossen werden.
- ② • Zähigkeit des Plattenmaterials bei minimaler Betriebstemperatur $\geq 27\text{J}$.
• Bruchdehnung des Plattenmaterials $\geq 14\%$.
- ③ • Überschneidungen zwischen der Lage der Zylinder-Befestigungslöchern und den Gaskanälen sind zu vermeiden.
• Um das Volumen des Systems zu vergrößern, wählen Sie Gasdruckfedern mit dem nächst größeren Hub.
- ④ • Die Durchgangsbohrungen sauber fertigen
• Blinde Kanäle vermeiden.

FR Pour une conception plus facile et de l'épargne des coûts de fabrications suivez les instructions ci-dessous

- ① • Pour relier le panneau utiliser, si possible, les canaux du gaz existents.
• Alternativement, joindre le panneau en utilisant des tubes et des raccords.
- ② • Résilience du matériau de la plaque à la température minimale de fonctionnement $\geq 27\text{J}$.
• Allongement à la rupture du matériau de la plaque $\geq 14\%$.
- ③ • Eviter l'interférence entre les trous de fixation des ressorts et les canaux du gaz.
• Sélectionner des ressorts avec des courses majeures pour augmenter le volume du système.
- ④ • Réaliser des trous débouchants et nettoyez correctement.
• Eviter les trous sans issue.

ES Para facilitar el diseño y poder reducir costes de producción se recomienda seguir las instrucciones indicadas a continuación

- ① • En la medida de lo posible usar los canales de gas existentes para conectar el panel.
• Como alternativa, conectar el panel con tuberías y racores.
- ② • Resiliencia del material de la placa a la temperatura mínima de uso $\geq 27\text{J}$.
• Alargamiento a la rotura del material de la placa $\geq 14\%$.
- ③ • Evitar la interferencia entre los orificios de fijación de los cilindros y los canales de gas.
• Seleccionar cilindros con mayores carreras para aumentar el volumen del sistema.
- ④ • Mecanizar agujeros pasantes en la placa y limpiar adecuadamente.
• Evitar agujeros ciegos.

PT Para facilitar o desenho e economizar custos de produção seguir as orientações abaixo mencionados

- ① • Para ligar o painel, se possível, usar os canais de gás existentes.
• Em alternativa conecte o painel com tubos e acessórios.
- ② • Placa com resistencia minima a temperatura minima de $> 27\text{J}$.
• Alongamento de ruptura do material da placa $\geq 14\%$.
- ③ • Evitar a interferência entre os orificios de fixação dos cilindros e os canais de gás.
• Escolher os cilindros com curso mais grande para aumentar o volume do sistema.
- ④ • Realizar orificios de passagem par toda a placa e bem limpar.
• Evitar orificios sem saída.

Series	Model	Rev. code	Version	Fixing pattern	Thread size D x A	Ø E		Ø D		H		Ø S		Seal code	Maintenance kit
						mm	inch	mm	inch	mm	inch	mm	inch		
NML	25	A	E	α	M6 x 9	≥ 14	≥ 0.55	6	0.24	1,2	0.05	10,5	0.41	50GE12A	-
	32	A	E	α	M6 x 9	≥ 14	≥ 0.55	6	0.24	1,2	0.05	10,5	0.41	50GE12A	39BMGNSN00032AE
	38	A	E	α	M8 x 12	≥ 15	≥ 0.59	8	0.31	1,2	0.05	13,0	0.51	50GE13A	39BMGNSN00038AE
	50	A	E	α	M10 x 15	≥ 16,5	≥ 0.65	10	0.39	2,0	0.08	18,0	0.71	50GE11A	39BMNML00050AE
	63	A	E	α	M10 x 15	≥ 16,5	≥ 0.65	10	0.39	2,0	0.08	18,0	0.71	50GE11A	39BMNML00063AE
	75	A	E	α	M12 x 18	≥ 18,5	≥ 0.73	12	0.47	1,5	0.06	21,0	0.83	50GE14A	39BMNML00075AE
NMX	19	A	E	α	M6 x 9	≥ 14	≥ 0.55	6	0.24	1,2	0.05	8,0	0.31	500R1000600	-

E versions

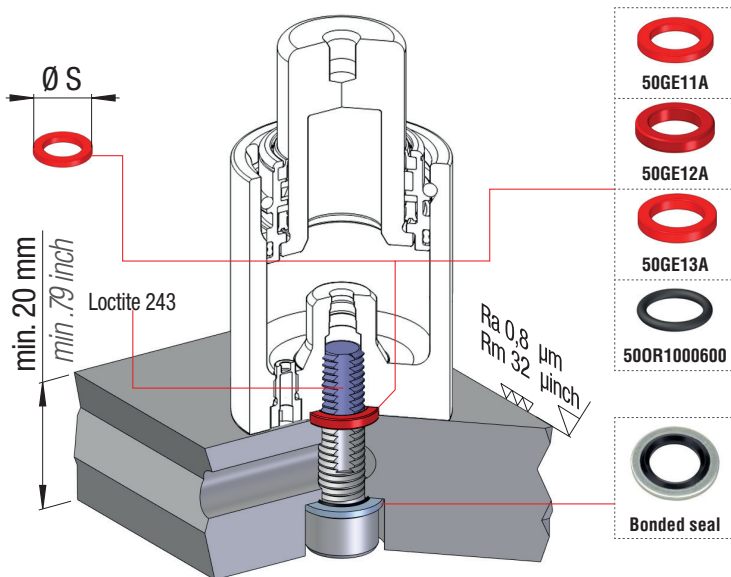

Example thread size M8 x 12

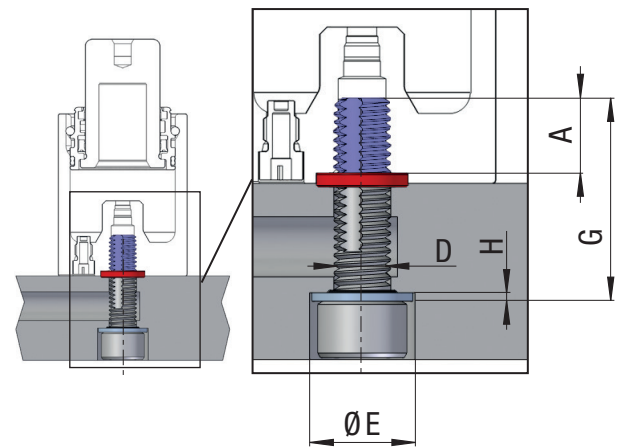

A	D
Profondità filetti Thread depth Gewindetiefe Profondeur filet Profundidad rosca Profundidade rosca	Dimensione viti Screw dimension Schraubengröße Dimension vis Dimensión tornillos Dimensão parafusos

Ø S
Ø Guarnizione piastra - cilindro Ø Plate - Gas spring seal Ø Platten - Zylinder Dichtung Ø Joint plaque - cylindre Ø Retén Placa - Cilindro Ø Junta Placa - Cilindro

Model	Code screw	G	
		mm	inch
NML25 NML32 NMX19	39VM6X020SPEM	20	0.79
	39VM6X025SPEM	25	0.98
	39VM6X030SPEM	30	1.18
	39VM6X035SPEM	35	1.38
	39VM6X040SPEM	40	1.57
	39VM6X050SPEM	50	1.97
NML38	39VM6X060SPEM	60	2.36
	39VM8X025SPEM	25	0.98
	39VM8X030SPEM	30	1.18
	39VM8X035SPEM	35	1.38
	39VM8X040SPEM	40	1.57
	39VM8X050SPEM	50	1.97
	39VM8X060SPEM	60	2.36

Model	Code screw	G	
		mm	inch
NML50 NML63	39VM10X25SPEM	25	0.98
	39VM10X30SPEM	30	1.18
	39VM10X35SPEM	35	1.38
	39VM10X40SPEM	40	1.57
	39VM10X50SPEM	50	1.97
	39VM10X60SPEM	60	2.36
NML75	39VM12X40SPEM	40	1.57
	39VM12X50SPEM	50	1.97
	39VM12X60SPEM	60	2.36



- IT** Corse e ingombri uguali al cilindro autonomo
- EN** Strokes and sizes same to self-contained gas spring
- DE** Hüben und Abmessungen gleiche zu den Autonomem Gdf
- FR** Courses et encombrement égaux à ceux du Cylindre autonome
- ES** Carreras y dimensiones iguales a las del cilindro autónomo
- PT** Cursos e dimensões iguais às do cilindro autónomo

MOUNTING HOLES

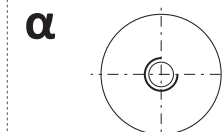

Series	Model	Rev. code	Version	Fixing pattern	Thread size D x A	Ø I		Ø F		Ø S		Seal code	Maintenance kit
						mm	inch	mm	inch	mm	inch		
NCS	32	A	E	β	M6 x 9	15	0.59	5	0.20	7,5	0.29	50GE04A	-
	32.2	A	E	β	M6 x 9	15	0.59	5	0.20	7,5	0.29	50GE04A	-
	38	A	E	β	M6 x 10	20	0.79	5	0.20	7,5	0.29	50GE04A	39BMMP01000AE
	50	A	E	β	M8 x 12	20	0.79	5	0.20	7,5	0.29	50GE04A	39BMMP02000AE
	63	A	E	β	M8 x 12	20	0.79	5	0.20	7,5	0.29	50GE04A	39BMMP03000AE

E version

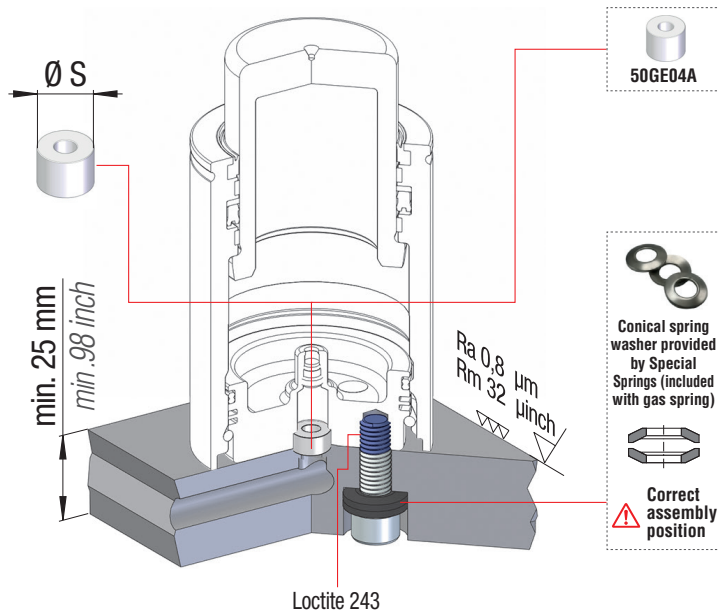

Example thread size M6 x 9

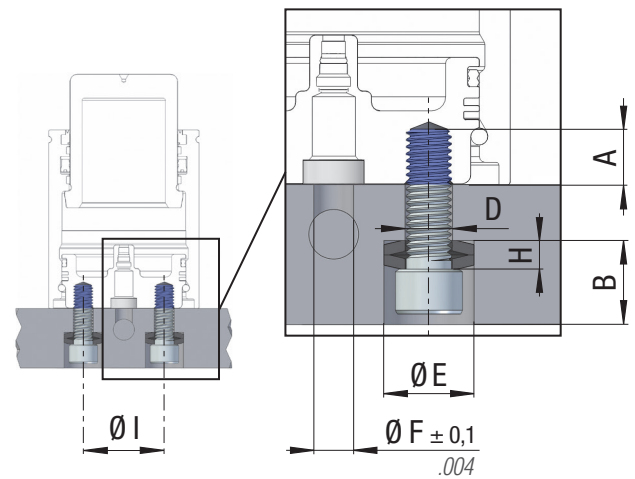

Ø I	D	A	B
Interasse fissaggio Fixing c.t.c. distance Mittenabstand Entraxe Distancia centros Distância eixos	Dimensione viti Screw dimension Schraubengröße Dimension vis Dimensión tornillos Dimensão parafusos	Profondità filetti Thread depth Gewindetiefe Profondeur filet Profundidad rosca Profundidade rosca	Profondità lamatura Depth of counterbore Senkungstiefe Profondeur du lamage Profundidad del contraladro Profundida do alojamento
Ø E	Ø F	Ø S	H
Ø lamatura Ø counterbore Ø Senkung Ø lamage Ø Alojamiento Ø alojamento	Ø Foro piastra - cilindro Ø Plate - Gas spring hole Ø Platten - Zylinder Loch Ø Trou plaque - cylindre Ø Alojamiento Placa - Cilindro Ø Furo Placa - Cilindro	Ø Guarnizione piastra - cilindro Ø Plate - Gas spring seal Ø Platten - Zylinder Dichtung Ø Joint plaque - cylindre Ø Retén Placa - Cilindro Ø Junta Placa - Cilindro	Spessore rosette Thickness of washers Dicke Sicherheitsscheiben Épaisseur des rondelles Espesor de las arandelas Espessura das arruelas

! Sostituire viti di fissaggio e rosette coniche ogni 1.000.000 di cicli.
Replace fixing screws and conical spring washers every 1 million cycles.
Alle 1 Mio. Hübe Befestigungsschrauben und Sicherheitsscheiben austauschen.
Remplacez les vis de fixation et les rondelles coniques à chaque million de cycles.
Reemplazar los tornillos de fijación y las arandelas cónicas cada 1 millón de ciclos.
Substituir a cada 1 milhão de ciclos os parafusos e arrelas de segurança.

Model	Ø E		B		H		Washer code for replacement
	mm	inch	mm	inch	mm	inch	
NCS 32	≥10,25	≥0.40	≥9,15	≥0.36	3,15	≥0.12	49RC06A
NCS 32.2	≥10,25	≥0.40	≥9,15	≥0.36	3,15	≥0.12	49RC06A
NCS 38	≥10,25	≥0.40	≥9,15	≥0.36	3,15	≥0.12	49RC06A
NCS 50	≥17,30	≥0.68	≥12,00	≥0.47	4,00	≥0.16	49RCHS08A
NCS 63	≥17,30	≥0.68	≥12,00	≥0.47	4,00	≥0.16	49RCHS08A



- IT** Corse e ingombri uguali al cilindro autonomo
- EN** Strokes and sizes same to selfcontained gas spring
- DE** Hüben und Abmessungen gleiche zu den Autonomen Gdf
- FR** Courses et ecombrement égaux à ceux du Cylindre autonome
- ES** Carreras y dimensiones iguales a las del cilindro autónomo
- PT** Cursos e dimensões iguais às do cilindro autónomo

MOUNTING HOLES

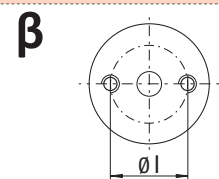

Series	Model	Rev. code	Version	Fixing pattern	Thread size D x A	Ø I		Ø F		Ø S		Seal code	Maintenance kit
						mm	inch	mm	inch	mm	inch		
NMX	50	A	E	β	M8 x 12	20	0.79	5	0.20	10,5	0.41	50GE12A	39BMNML00050AE CU 10 ÷ 100 39BMNMX00050AE CU 125 ÷ 200

E version

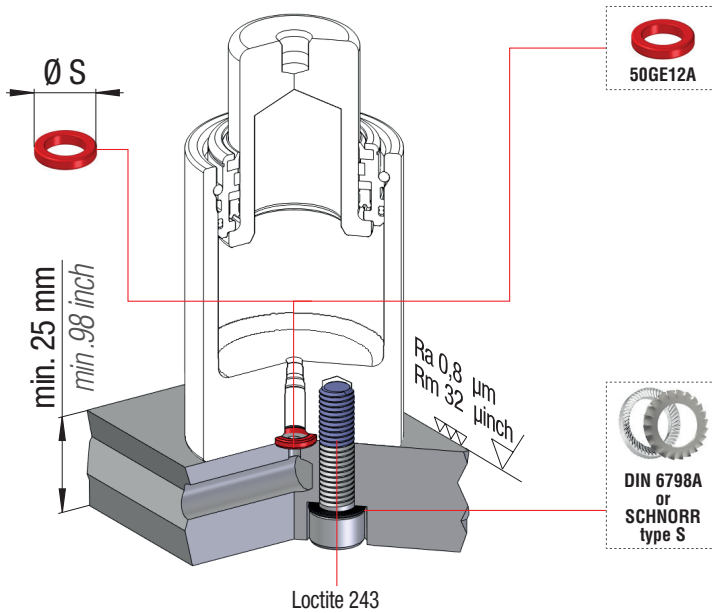

Example thread size M8 x 12

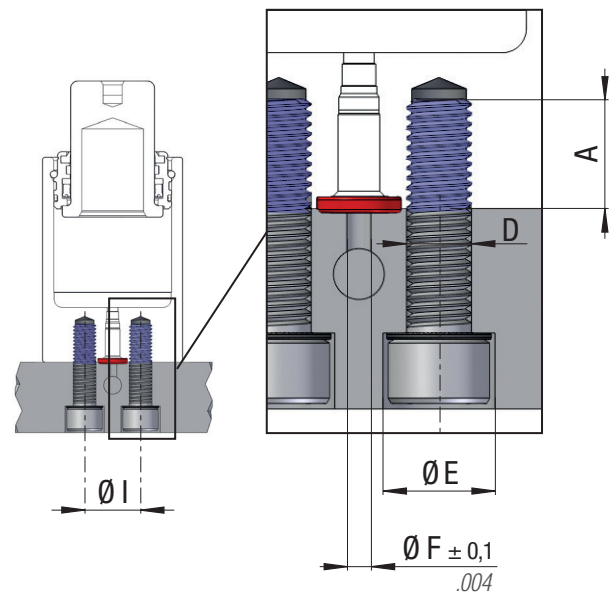

Ø I	D	A
Interasse fissaggio Fixing c.t.c. distance Mittenabstand Entraxe Distancia centros Distância eixos	Dimensione viti Screw dimension Schraubengröße Dimension vis Dimensión tornillos Dimensão parafusos	Profondità filetti Thread depth Gewindetiefe Profondeur filet Profundidad rosca Profundidade rosca
Ø E	Ø F	Ø S
Ø lamatura Ø counterbore Ø Senkung Øamage Ø Alojamiento Ø alojamento	Ø Foro piastra - cilindro Ø Plate - Gas spring hole Ø Platten - Zylinder Loch Ø Trou plaque - cylindre Ø Alojamiento Placa - Cilindro Ø Furo Placa - Cilindro	Ø Guarnizione piastra - cilindro Ø Plate - Gas spring seal Ø Platten - Zylinder Dichtung Ø Joint plaque - cylindre Ø Retén Placa - Cilindro Ø Junta Placa - Cilindro

Sostituire viti di fissaggio e rosette coniche ogni 1.000.000 di cicli.
Replace fixing screws and conical spring washers every 1 million cycles.
Alle 1 Mio. Hübe Befestigungsschrauben und Sicherheitscheiben austauschen.
Remplacez les vis de fixation et les rondelles coniques à chaque million de cycles.
Reemplazar los tornillos de fijación y las arandelas cónicas cada 1 millón de ciclos.
Substituir a cada 1 milhão de ciclos os parafusos e aruelas de segurança.



- IT** Corse e ingombri uguali al cilindro autonomo
- EN** Strokes and sizes same to self-contained gas spring
- DE** Hüben und Abmessungen gleiche zu den Autonomen Gdf
- FR** Courses et ecombement égaux à ceux du Cylindre autonome
- ES** Carreras y dimensiones iguales a las del cilindro autónomo
- PT** Cursos e dimensões iguais às do cilindro autónomo

MOUNTING HOLES

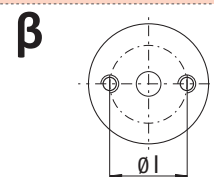



HOW TO ORDER



IT Stato di fornitura

Tutti i cilindri Easy manifold sono forniti con guarnizione e foglio istruzioni.

EN Supply status

All Easy Manifold gas springs are supplied with seal and operating instructions .

DE Lieferumfang

Alle Gasdruckfeder Easy Manifold sind mit Dichtung und Bedienungsanleitungen ausgestattet.

FR État de fourniture

Tous les vérins Easy manifold sont fournis avec un joint et une fiche d'instructions.

ES Condiciones de suministro

Todos los cilindros Easy manifold se suministran con reten y hoja de instrucciones.

PT Estado de abastecimento

Todos os cilindros Easy manifold vêm com uma junta e um folheto de instruções.

Mounting recommendations

! It is always required Loctite 243 or equivalent and the safety washers

Chiave dinamometrica
Torque wrench
Drehmomentschlüssel
Clé dynamométrique
Llave dinamométrica
Chave dinamométrica

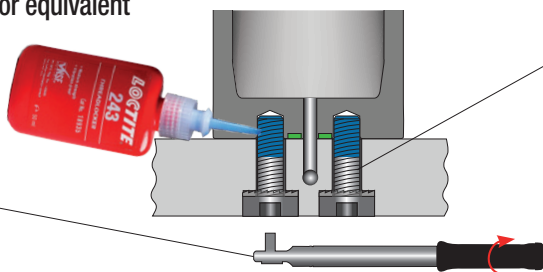

Torque force		
M6	class \geq 8.8	max 10 Nm
M8	class \geq 8.8	max 24 Nm
M10	class \geq 8.8	max 50 Nm
M12	class \geq 8.8	max 84 Nm

IT Raccomandazioni

- L'uso di viti di classe superiore alla 8.8, come 9.8, 10.9 e 12.9, è sempre possibile (questa indicazione non vale per la serie NCS).
- Si raccomanda di NON SUPERARE i valori della coppia di serraggio indicati per la classe 8.8 per qualsiasi classe di viti utilizzata.
- Impegnare sempre il filetto il più possibile, almeno il valore di Kmin.
- Massima attenzione nel montaggio della guarnizione di collegamento tra cilindro e piastra.

EN Recommendations

- The use of screws of higher class than 8.8, such as 9.8, 10.9 and 12.9, is always allowed (this information is not valid for the NCS Series).
- DO NOT EXCEED the fixed values for torque force indicated for class 8.8, in any other class of screws used.
- ALWAYS engage thread as much as possible at least Kmin.
- Extreme caution when assembling the connecting seal between plate and gas spring.

DE Hinweise

- Schrauben mit einer höheren Festigkeit als 8.8 verwenden. Höhere Festigkeitsklassen wie 9.8, 10.9 und 12.9 sind immer möglich (Diese Angabe gilt nicht für die NCS Baureihe).
- Das angegebene Drehmoment der Festigkeitsklasse 8.8 für andere Schrauben Festigkeitsklassen nicht überschreiten.
- Die komplette Gewindelänge ausnutzen, mind. Kmin.
- Vorsicht bei der Montage der Dichtungen zwischen den Gasdruckfedern und der Platte.
- Äußerste Vorsicht bzgl. des korrekten Drehmoments beim Einschrauben.

FR Reccomandacions

- L'usage de vis de classe supérieure au 8.8, tout comme 9.8, 10.9 et 12.9, est toujours possible (cette information n'est pas valable pour la série NCS).
- N'EXCEDEZ PAS la valeur de la couple de serrage indiqués pour la classe 8.8 pour n'importe quelle autre classe de vis utilisée.
- Engager toujours le filetages plus que possible, et au moins Kmin.
- Une extrême vigilance est recommandée pour l'assemblage du joint entre la plaque et le vérin.

ES Recomendaciones

- El uso de tornillos de calidad superior a 8.8, como 9.8, 10.9 y 12.9 está permitido (excepto para NCS).
- Se recomienda NO EXCEDER el par de apriete indicado para la clase 8.8 para cualquier calidad de tornillos utilizados.
- Utilizar la máxima longitud de rosca, como mínimo Kmin.
- Máxima atención en el montaje de la junta de conexión entre placa y cilindro.

PT Recomendações

- O uso de limitadores superiores a 8,8, tal como 9,8, 10,9 e 12,9, é sempre possível (não válido para a linha NCS).
- Recomendamos que você NÃO ULTRAPASSE os valores das especificações de torque para a classe 8,8 por os limitadores utilizados para qualquer classe.
- Sempre envolver a rosca, tanto quanto possível, pelo menos para Kmin.
- Máxima atenção quando fixar os vedantes conectores entre a placa e cilindro.

- Utilizzare SEMPRE i fori di fissaggio previsti.
- Massima attenzione alla corretta coppia di serraggio da applicare alle viti.
- Usare SEMPRE rondelle anti svitamento su cilindri e pannelli.
- Usare SEMPRE frena filetti tipo Loctite 243 su cilindri e pannelli.
- Non caricare il sistema Easy Manifold con pressione superiore alla massima consentita per ogni modello.

- ALWAYS use the fixing holes provided.
- Extreme caution to tightening torque to be applied to screws.
- ALWAYS use lock washers on gas springs and panels.
- ALWAYS use thread lock LOCTITE 243 on gas springs and panels.
- Do not charge the easy manifold system over the maximum allowed pressure for each gas spring model.

- IMMER die vorgesehen Befestigungslöcher verwenden
- IMMER Sicherungsscheiben auf die Zylindern und Kontrollarmaturen, verwenden.
- IMMER eine Schraubensicherung wie z.B. Loctite 243 auf die Zylindern und Kontrollarmaturen, verwenden.
- Das Easy Manifold System nicht mit einem höheren Druck laden als dem, der speziell für das Modell der Gasdruckfeder empfohlen wird.

- Utiliser TOUJOURS les trous de fixation prévus.
- Bien veiller à appliquer le couple de serrage correct aux vis.
- TOUJOURS utiliser les rondelles de verrouillage avec les cylindres et les panneaux.
- TOUJOURS utiliser la colle frein filet LOCTITE 243 avec les cylindres et les panneaux.
- Ne pas charger le système manifold au delà de la pression autorisée pour chaque modèle de vérin.

- SIEMPRE use los agujeros de fijación previstos.
- Máxima atención al correcto par de torsión que se aplica a los tornillos.
- Utilizar SIEMPRE arandelas autoblocantes por los cilindros y paneles.
- Utilizar SIEMPRE fijador de rosca tipo Loctite 243 por los cilindros y paneles.
- No cargar el sistema Easy Manifold con presión superior a la máxima permitida para cada tipo de cilindro.

- Use SEMPRE os furos de fixação fornecidos.
- Máxima atenção no torque de aperto aplicado nos parafuso.
- Utilizar SEMPRE as anilhas de travamento nos cilindros e painéis.
- Utilizar SEMPRE o fixador de rosca LOCTITE 243 nos cilindros e painéis.
- Não carregar o sistema EASY MANIFOLD acima da pressão máxima recomendada para cada modelo de cilindro.

Easy manifold control panel

code 39CP01A

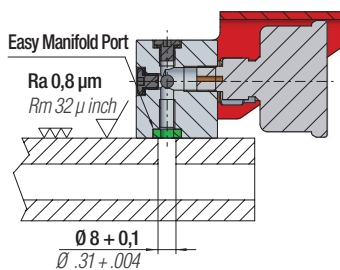
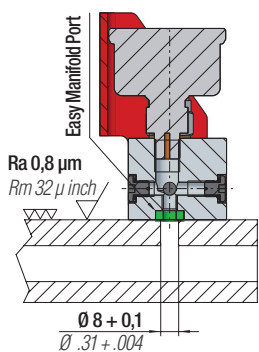
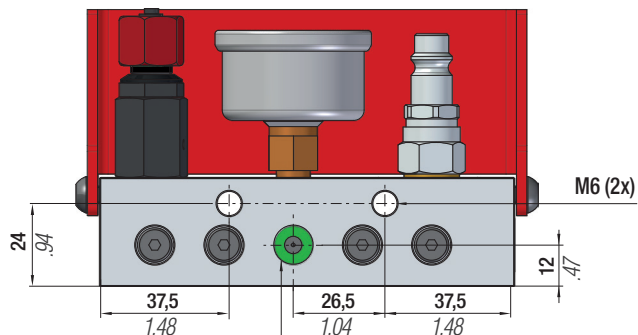
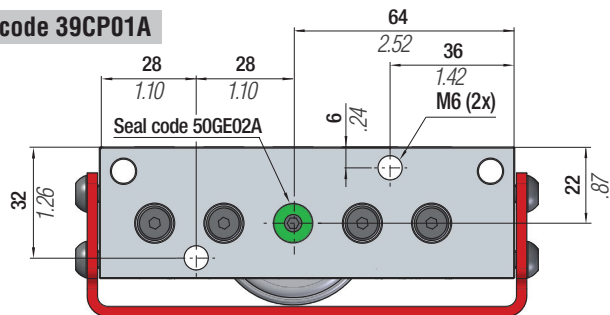

code 39CPVC

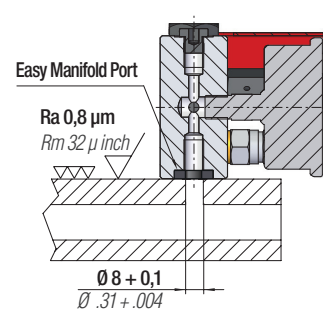
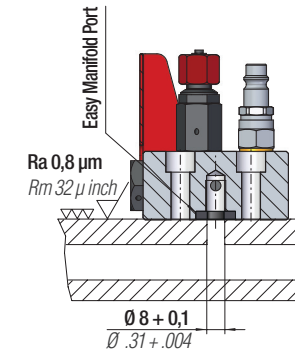
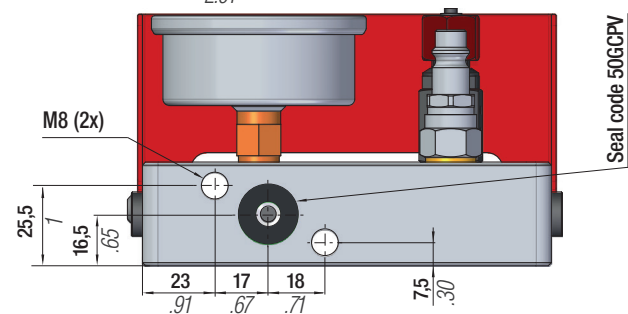
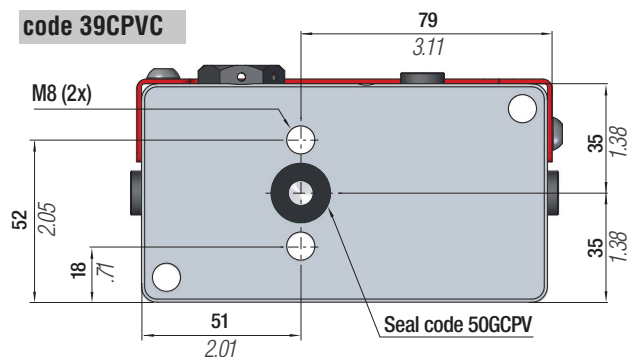

code 39MPCP

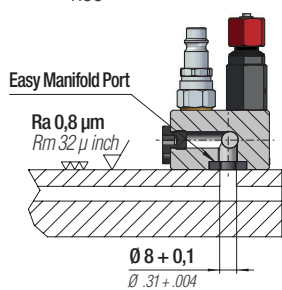
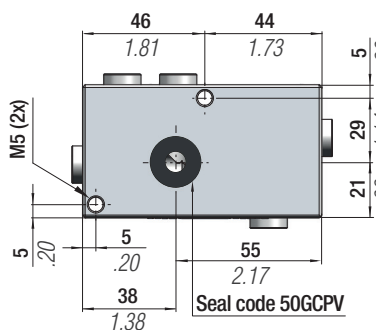

code 39CP14A

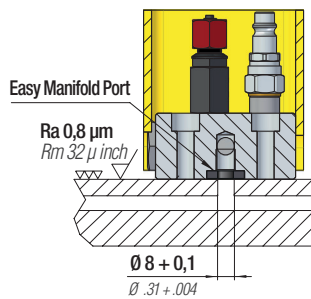
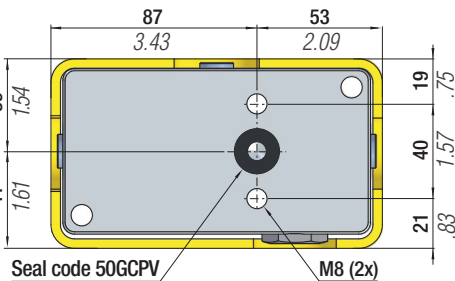

code 39CP07A

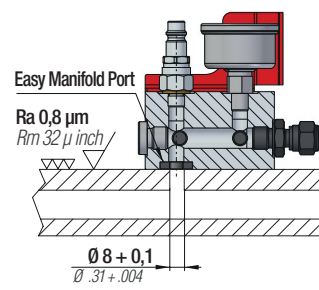
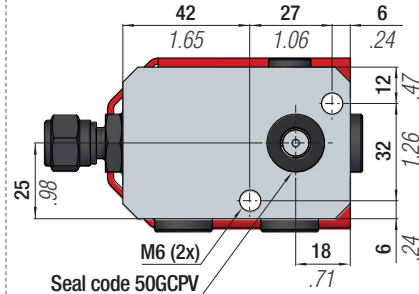

CONTROL PANEL CP01A



IT
Micro pannello di controllo composto da base in alluminio, manometro, valvola per caricamento e scaricamento, tappo di rottura sovrappressione e protezione in acciaio. Idoneo per la gestione di impianti collegati realizzati con micro hose e micro connections. 16 uscite M6.

EN
Micro control panel with aluminium base, gauge, charging and discharging valve, overpressure rupture plug and steel protection. Suitable for hose systems equipped with micro hose and micro connections. 16 M6 ports.

DE
Micro-Kontrollarmatur mit Aluminiumsockel, Manometer, Auffüll- und Ablassventil, Überdruck-Bruchstecker und Stahlabdeckung. Geeignet für Verbundsysteme mit Micro-Kupplung und -Schläuchen. 16 M6 Anschlüsse.

FR
Mini panneau de contrôle avec base aluminium, équipé de manomètre, valve de chargement et déchargement, bouchon de rupture de surpression et protection acier ; il est adapté aux systèmes connectés équipés de mini tuyaux et mini connexions. 16 Portes M6.

ES
Micropanel de control con base en aluminio, manómetro, válvula de carga y descarga, tapón de rotura por sobrepresión y protección en acero. Idóneo para la gestión de instalaciones de cilindros conectados entre sí con micro mangueras y micro racores. 16 salidas M6.

PT
Micro Painel de Control com base em alumínio, manómetro, válvula de carga e descarga, plugue ruptura sobrepresão e protecção em aço. Adequado para sistemas de mangueiras, equipado com micro mangueiras e micro conexões. 16 saídas M6.

code	Pressure Gauge	Rupture Plug	Easy Manifold	Gauge Angle Position
39CP01A-...	bar/psi	✓	✓ p.111	0°* 180°

HOW TO ORDER

code
39CP01A-180

Gauge angle position

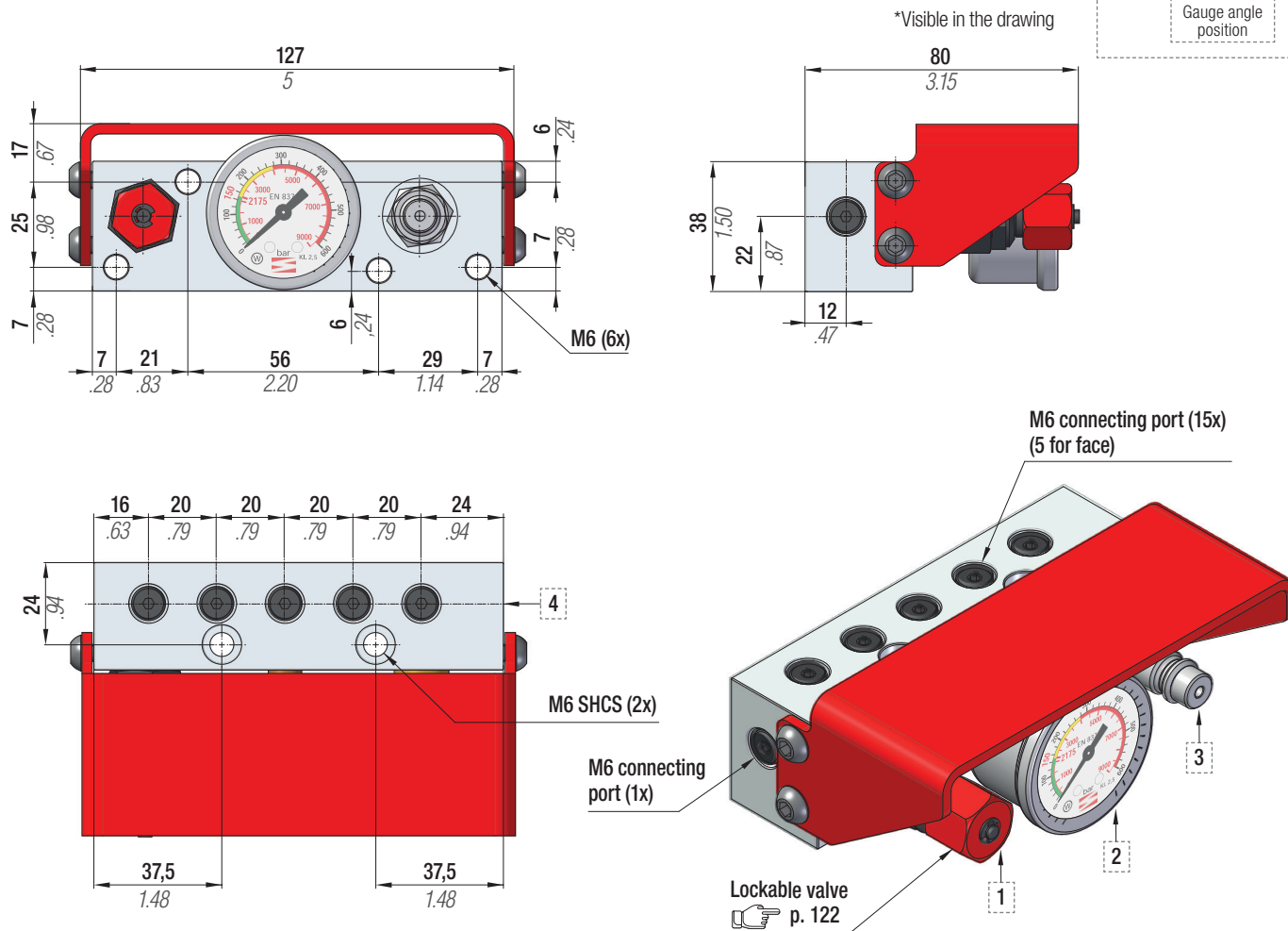

1	Valvola di scarico Discharging valve Auslaßventil Valve de déchargement Válvula de descarga Válvula de descarga	2	Manometro 0÷ 620 bar Pressure gauge 0÷620 bar Manometer 0÷ 620 bar Manomètre 0÷ 620 bar Manómetro 0÷ 620 bar Manómetro 0÷ 620 bar	3	Innesto rapido di caricamento Cejn Quick coupling for charging Cejn Steckkegel Cejn Accouplement rapide mâle Cejn Acoplamiento rápido para carga Cejn União rápida para carregamento Cejn	4	Tappo di rottura sovrappressione Over pressure rupture plug Überdruck-Bruchstecker Bouchon de rupture de surpression Tapón de rotura por sobrepresión Plugue ruptura sobrepresão
---	--	---	--	---	--	---	---

IT

Pannello standard per caricamento, regolazione, scaricamento e controllo della pressione nel sistema collegato. Consiste in una base provvista di manometro, valvola di caricamento e scaricamento, 3 uscite, protezione in acciaio. Può essere equipaggiato con disco di rottura (opzionale).

EN

Standard control panel to charge, adjust and check the pressure in the connected system. It consists of a plate with pressure gauge, charging and discharging valve, 3 outlets, steel case and can be equipped with a rupture disc (optional).

DE

Standard-Schaltarmatur zur Ladung, Regulierung, Entladung und Kontrolle des Drucks im angeschlossenen System. Bestehend aus einer Sockel mit Manometer, Lade- und Entladeventil, 3 Ausgängen sowie Schutzabdeckung aus Stahl. Kann mit einer Berstscheibe ergänzt werden (Zubehör).

FR



Panneau standard pour le chargement, le réglage, le déchargement et le contrôle de la pression dans le système relié. Il est formé par une embase équipée de manomètre, vanne de chargement et déchargement, 3 sorties, protection en acier. Il peut être équipé d'un disque de rupture (option).

ES

Panel estándar para la carga, regulación, descarga y control de la presión en sistemas de cilindros conectados. Consiste en una base provista de manómetro, válvula de carga y descarga, 3 salidas, protección en acero. Puede equiparse con disco de rotura (opcional).

PT

Painel standard para carga, regulação, descarga e controlo da pressão no sistema ligado. É composto por uma base com manómetro. Válvula de carga e de descarga, 3 saídas, protecção em aço. Pode ser equipado com disco de rotura (opcional).

code	Pressure Gauge	Rupture Plug	Easy Manifold  p.111	Gauge Angle Position 	
				0°*	180°
39CPVC-...	bar/psi	✗	✓	-	180
39CPVC-... + 39DR004	bar/psi	✓	✓	-	180
39CPVC-... + 39TS460	bar/psi	✓	✓	-	180

*Visible in the drawing

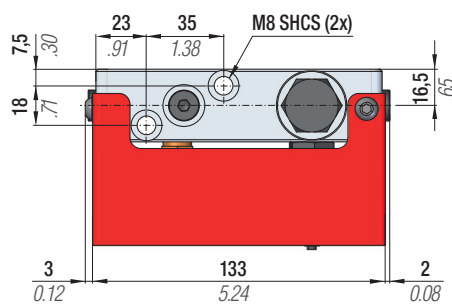
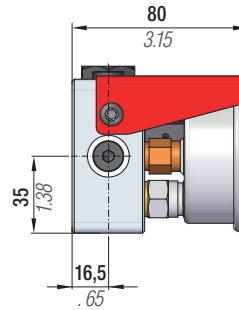
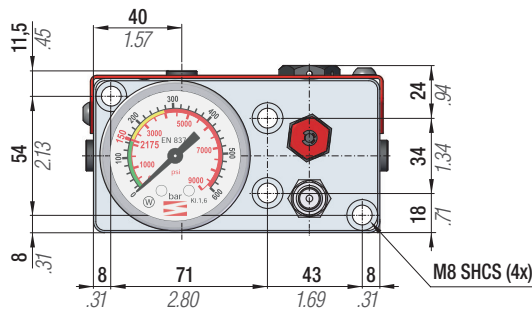

HOW TO ORDER

code

39CPVC-180

Gauge angle position

code 39TS460	4.2 - option
code 39DR004	4.1 - option
standard	4

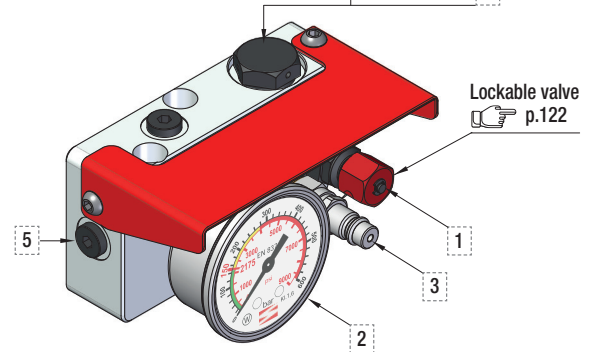

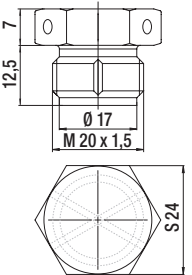
1	Valvola di scarico Discharging valve Auslaßventil Valve de déchargement Válvula de descarga Válvula de descarga	2	Manometro 0÷ 620 bar Pressure gauge 0÷620 bar Manometer 0÷ 620 bar Manomètre 0÷ 620 bar Manómetro 0÷ 620 bar Manómetro 0÷ 620 bar	3	Innesto rapido di caricamento Cejn Quick coupling for charging Cejn Steckkegel Cejn Accouplement rapide mâle Cejn Acoplamiento rápido para carga Cejn União rápida para carregamento Cejn	4	Tappo di chiusura M20 Closing plug M20 Verschlussstopfen M20 Bouchon de fermeture M20 Tapón de cierre M20 Plugue de fechamento M20	code: 39TS460
4.1	Tappo di rottura sovrappressione Over pressure rupture plug Überdruck-Bruchstecker Bouchon de rupture de surpression Tapón de rotura por sobrepresión Plugue ruptura sobrepresão	4.2	Tappo di sicurezza sovrappressione CE Overpressure safety plug CE Überdruck Sicherheitsstecker CE Bouchon de sécurité surpression CE Tapón de rotura por sobrepresión CE Bujão de segurança sobrepresão	5	Fori di collegamento 1/8"G (4x) 1/8"G connecting ports (4x) Anschlussöffnung 1/8"G (4x) Trous de raccordement 1/8"G (4x) Agujeros de conexión 1/8"G (4x) Furo de conexão 1/8"G (4x)			

CONTROL PANEL MCPC / CP19A



IT

Il mini pannello di controllo Special Springs, grazie a un design miniaturizzato e unico, offre una grande flessibilità d'uso. Consiste in un blocchetto di alluminio provvisto di manometro, valvola di caricamento e scaricamento, 4 uscite, valvola d'intercettazione e tappo di rottura sovrappressione.

EN

The Special Springs mini control panel, thanks to its unique miniaturized design, offers wide flexibility of use, it consists of a aluminium block with pressure gauge, charging and discharging valve, 4 outlets, on-off valve and overpressure rupture plug.

DE

Die Mini-Steuerung Special Springs bietet dank ihres miniaturisierten und einzigartigen Designs größte Benutzungsflexibilität, Bestehend aus einem Aluminiumblock mit Manometer, Lade- und Entladeventil, 4 Ausgängen, Sperrventil und Überdruck-Bruchstecker.

FR



Grâce à une conception miniaturisée et unique, le mini-panneau de contrôle Special Springs offre une grande souplesse d'utilisation. Il est formé par une plaque en aluminium équipée de manomètre, vanne de chargement et déchargement, 4 sorties, vanne d'arrêt et Bouchon de rupture surpression.

ES

El mini-panel de control Special Springs, gracias a su compacto y exclusivo diseño, ofrece una gran flexibilidad de uso. Consiste en un bloque de aluminio provisto de manómetro, válvula de carga y descarga, 4 salidas, válvula de cierre y tapón de rotura por sobrepresión.

PT

O mini-painel de controlo Special Springs, graças a um design miniaturizado e exclusivo, oferece uma grande flexibilidade de utilização. É composto por um bloco em alumínio com manómetro, válvula de carga e de descarga, 4 saídas, válvula de intercepção e plugue ruptura sobrepressão.

code	Pressure Gauge	Rupture Plug	Shut off valve	Easy Manifold  p.111	Gauge Angle Position 	
					0°*	270°
39MCPC-...	bar/psi	✓	✓	✓	-	270
39CP19A-...	bar/psi	✓	✗	✓	-	270

*Visible in the drawing

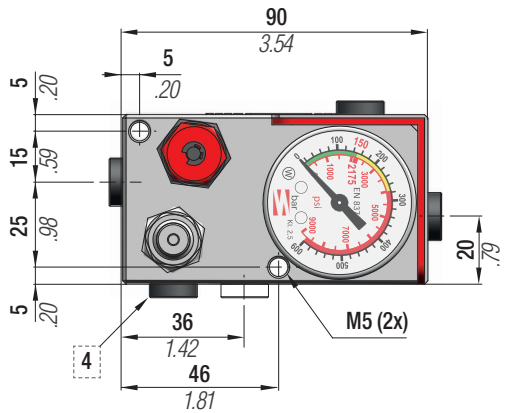

Lockable valve
 p. 122

G 1/8" - Port (5x)

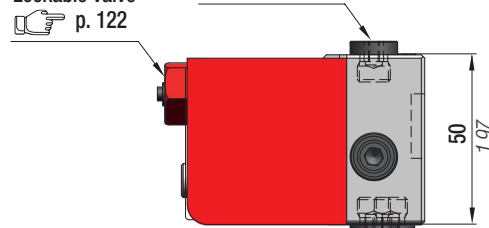

HOW TO ORDER

code
39MCPC-270
Gauge angle position

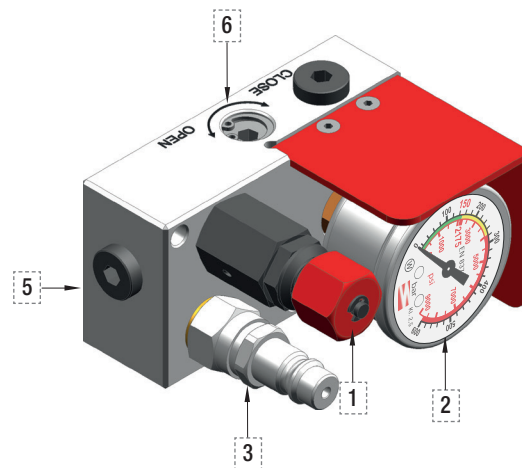
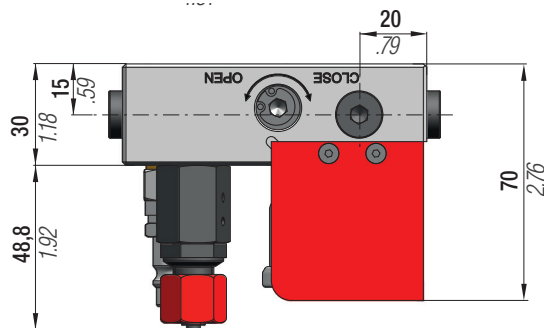

1	Valvola di scarico Discharging valve Auslaßventil Valve de déchargement Válvula de descarga Válvula de descarga	2	Manometro 0÷ 620 bar Pressure gauge 0÷620 bar Manometer 0÷ 620 bar Manomètre 0÷ 620 bar Manómetro 0÷ 620 bar Manómetro 0÷ 620 bar
---	--	---	--

3	Innesto rapido di caricamento Cejn Quick coupling for charging Cejn Steckkegel Cejn Accouplement rapide mâle Cejn Acoplamiento rápido para carga Cejn União rápida para carregamento Cejn	4	Tappo di rottura sovrappressione Over pressure rupture plug Überdruck-Bruchstecker Bouchon de rupture de surpression Tapón de rotura por sobrepresión Plugue ruptura sobrepressão	5	Fori di collegamento 1/8"G (5x) 1/8"G connecting ports (5x) Anschlussöffnung 1/8"G (5x) Trous de raccordement 1/8"G (5x) Agujeros de conexión 1/8"G (5x) Furo de conexão 1/8G (5x)	6	Valvola di intercettazione Shut off valve Sperrventil Valve d'arrêt Válvula de intercepção Válvula de fecho
---	--	---	--	---	---	---	--

IT

Pannello di controllo con base in alluminio provvisto di manometro, valvola di carica-mento e scaricamento e tappo di rottura sovrappressione, protezione in acciaio, 3 uscite da 1/4" gas e un uscita da 1/8" gas per gestione sistemi collegati.

EN

Control panel with aluminium base, equipped with gauge, charging and discharging valve, over pressure rupture plug, steel protection and three 1/4" and one 1/8" gas outlets for hose system man-aging.

DE

Kontrollarmatur mit Aluminiumgehäuse, Manometer, Auffüll- und Ablasventil, Überdruck-Bruchstecker, Stahlabdeckung, drei 1/4" und eine 1/8" Gas-Anschlüsse zur Steuerung der Ver-bundsysteme.

FR

Panel de contrôle avec base en aluminium pourvu de manomètre, valve de chargement-déchargement, bouchon de rupture de surpression, protection en acier et trois sorties 1/4 gaz et une sortie 1/8 gaz pour la gestion des systèmes connectés.

ES

Panel de control con base de aluminio pro-visto de manómetro, válvula de carga y de-scarga, tapón de rotura por sobrepresión, protección en acero, 3 salidas de 1/4" gas y 1 salida de 1/8" gas para gestión de sistemas co-nectados.

PT

Painel de controlo com base de alumi-nio, equipado com manómetro, válvula de carga e descarga, plugue ruptura so-brepressão, sistema de protecção de aço, três tomadas de 1/4" e uma 1/8" gas para ligação a mangueiras.

code	Pressure Gauge	Pressure Switch	Rupture Plug	Easy Manifold 👉 p.111	Gauge Angle Position ◻		
					0°*	180°	270°
39CP07A-...	bar/psi	✗	✓	✓	-	180	270
39CP10A-...	bar/psi	✓	✓	✓	-	180	270
39CP12A-...	bar/psi	✗	✗	✓	-	180	270

*Visible in the drawing

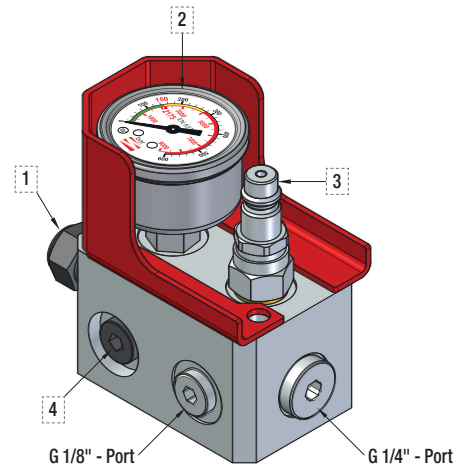
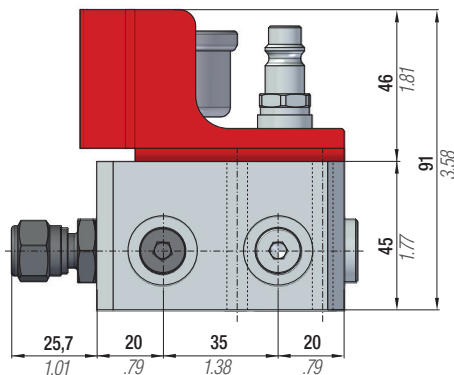
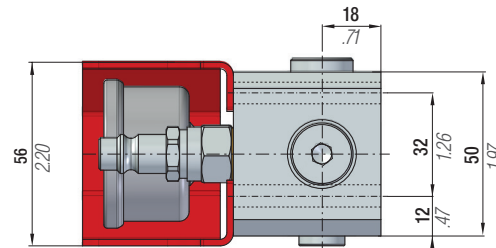
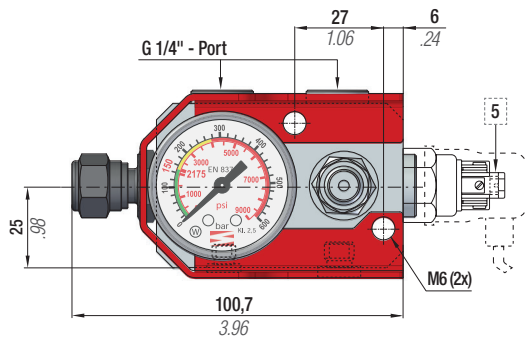

HOW TO ORDER

code

39CP07A-180

Gauge angle position

1	Valvola di scarico Discharging valve Auslaßventil Valve de déchargement Válvula de descarga Válvula de descarga	2	Manometro 0÷ 620 bar Pressure gauge 0÷ 620 bar Manometer 0÷ 620 bar Manomètre 0÷ 620 bar Manómetro 0÷ 620 bar Manómetro 0÷ 620 bar	3	Innesto rapido di carica-mento Cejn Quick coupling for charging Cejn Steckkegel Cejn Accouplement rapide mâle Cejn Acoplamiento rápido para carga Cejn União rápida para carregamento Cejn	4	Tappo di rottura sovrappressione Over pressure rupture plug Überdruck-Bruchstecker Bouchon de rupture de surpression Tapón de rotura por sobrepresión Plugue ruptura sobrepressão	5	Pressostato 50÷300 bar Pressure switch 50÷300 bar Druckwächter 50÷300 bar Pressostat 50÷300 bar Pressostato 50÷300 bar Pressostato 50÷300 bar
---	--	---	---	---	---	---	--	---	--

CONTROL PANEL CP14A (Daimler standard)



IT

Pannello di controllo a standard Daimler. Base in alluminio provvisto di manometro, valvola di caricamento e scaricamento, pressostato e protezione in acciaio. 3 uscite 7/16-20UNF per gestione sistemi collegati. Può essere equipaggiato con tappo di rottura sovrappressione.

EN

Control panel according to Daimler standard. Made of aluminum base. Equipped with pressure gauge, charging and discharging valve, pressure switch and steel protection. Three 7/16-20UNF gas outlets for managing hose system. It can be equipped with over pressure rupture plug.

DE

Kontrollarmatur nach Daimler-Norm. Mit Aluminiumgehäuse, Manometer, Auffüll- und Ablassventil, Druckwächter und Stahlabdeckung. Drei 7/16-20UNF Gas-Anschlüsse zur Steuerung der Verbundsysteme. Einheit kann mit Überdruck-Bruchstecker ausgestattet werden.

FR

Panneau de contrôle selon le standard Daimler. Avec base en aluminium, manomètre, valve de chargement-déchargement, pressostat et protection en acier. Trois sorties 7/16-20UNF gaz pour la gestion des systèmes connectés. Il peut être équipé avec bouchon de rupture de surpression.

ES

Panel de control según standard Daimler. Con base de aluminio, manómetro, válvula de carga y descarga, pressostato y protección en acero. 3 salidas de 7/16-20UNF gas para gestión de sistemas conectados. Puede equiparse con tapón de rotura por sobrepresión.

PT

Painel de controlo de acordo com o Standard Daimler. Fabricado a partir de uma base de alumínio. Equipado com manómetro, válvula de carga e descarga, pressostato e sistema de protecção de aço. Três saída de gás 7/16-20UNF para ligação a mangueiras. Pode ser equipado com plugue ruptura sobrepresão.

code	Pressure Gauge	Pressure Switch	Rupture Plug	Easy Manifold 👉 p.111	Gauge Angle Position ↻	
					0°*	180°
39CP14A-...	bar/psi	✓	✗	✓	-	180
39CP14A-... + 39DR004	bar/psi	✓	✓	✓	-	180
39CP14A-... + 39TS460	bar/psi	✓	✓	✓	-	180

*Visible in the drawing

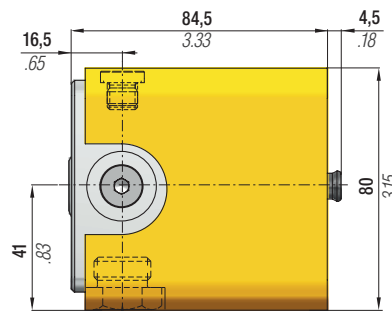
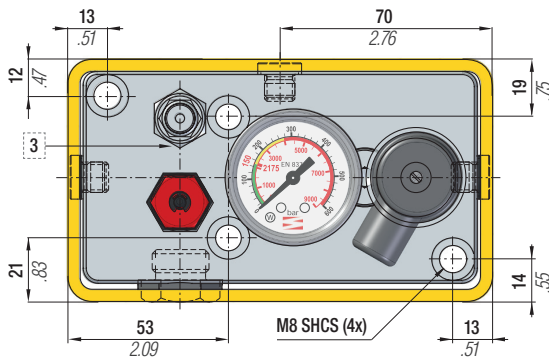

HOW TO ORDER

code

39CP14A-180

Gauge angle position

code 39TS460 5.2 - option
code 39DR004 5.1 - option
standard 5

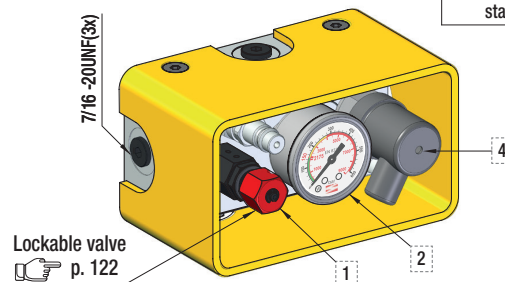
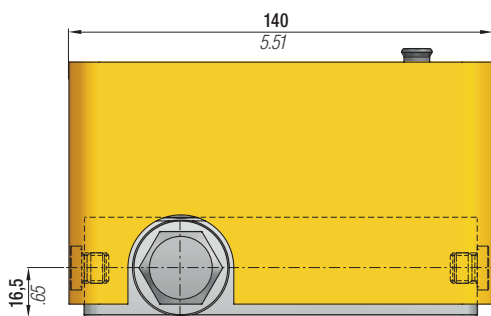

1 Valvola di scarico Discharging valve Auslaßventil Valve de déchargement Válvula de descarga Válvula de descarga	2 Manometro 0÷ 620 bar Pressure gauge 0÷ 620 bar Manometer 0÷ 620 bar Manomètre 0÷ 620 bar Manómetro 0÷ 620 bar Manómetro 0÷ 620 bar	3 Innesto rapido di caricamento Cejn Quick coupling for charging Cejn Steckkegel Cejn Accouplement rapide mâle Cejn Acoplamiento rápido para carga Cejn União rápida para carregamento Cejn	4 Pressostato 50÷300 bar Pressure switch 50÷300 bar Druckwächter 50÷300 bar Pressostat 50÷300 bar Presostato 50÷300 bar Pressostato 50÷300 bar	code: 39TS460
5 Tappo di chiusura M20 Closing plug M20 Verschlussstopfen M20 Bouchon de fermeture M20 Tapon de cierre M20 Plugue de fechamento M20	5.1 Tappo di rottura sovrappressione Over pressure rupture plug Überdruck-Bruchstecker Bouchon de rupture de surpression Enchufe de ruptura de sobrepresión Plugue ruptura sobrepresão		5.2 Tappo di sicurezza sovrappressione CE Overpressure safety plug CE Überdruck Sicherheitsstecker CE Bouchon de sécurité surpression CE Enchufe de seguridad sobrepresion CE Bujão de segurança sobrepresão CE	

IT

Pannello di controllo con base in alluminio provvisto di sensore di pressione EYE, valvola di caricamento e scaricamento, tappo di rottura sovrappressione, protezione in acciaio, innesto rapido di caricamento Cejn e 3 uscite da 1/8" gas per gestione sistemi collegati.

EN

Control panel with aluminium base, equipped with pressure sensor EYE, charging and discharging valve, overpressure rupture plug, steel protective cover, Cejn-quick coupling for charging and three G 1/8" ports for managing linked systems.

DE

Kontrollarmatur mit Aluminiumgehäuse mit Drucksensor EYE, Befüll- und Ablassventil, Überdruck-Berstsicherung, Schutzabdeckung aus Stahl, Cejn-Schnellkupplung zur Befüllung, und drei G1/8 Anschlussgewinden zur Steuerung von Verbundsystemen.

FR

Panneau de contrôle avec base en aluminium, équipé du capteur de pression EYE, valve de chargement-déchargement, bouchon de rupture pour surpression, couverture de protection en acier, raccord rapide Cejn pour le chargement et trois ports G 1/8" pour la gestion des systèmes connectés.

ES

Panel de control con base de aluminio equipado con sensor de presión EYE, válvula de carga y descarga, tapón de rotura por sobrepresión, protección de acero, acoplamiento rápido Cejn y 3 salidas 1/8" gas para gestión de sistemas conectados.

PT

Painel de controle com base em alumínio, fornecido com o sensor de pressão EYE, válvula de carregamento e descarregamento, bujão de ruptura para sobre pressão, cobertura protetora em aço, engate rápido de carregamento CEJN e 3 saídas G1/8" para a gestão de sistemas de mangueiras.

code	Pressure Gauge	Rupture Plug	Easy Manifold
39CP23A	bar/psi/MPa	✓	✓

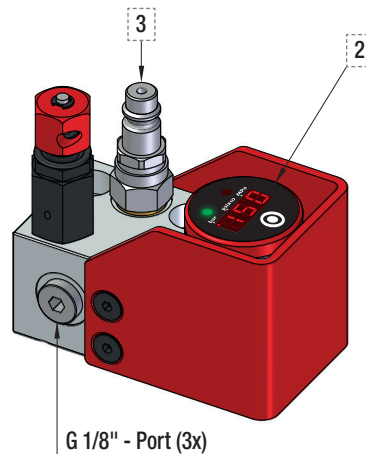
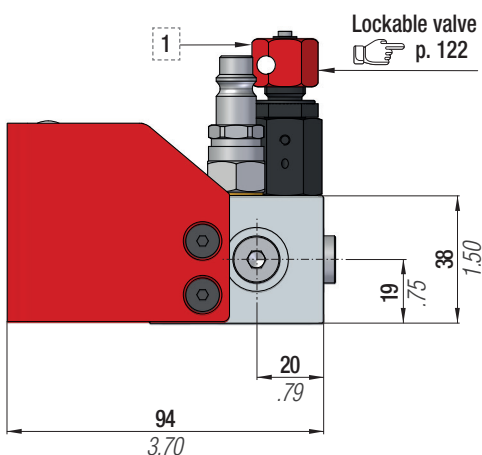
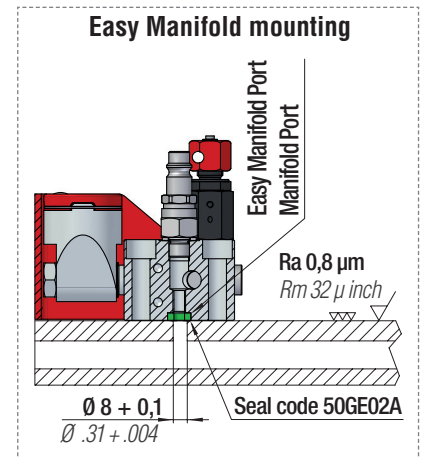
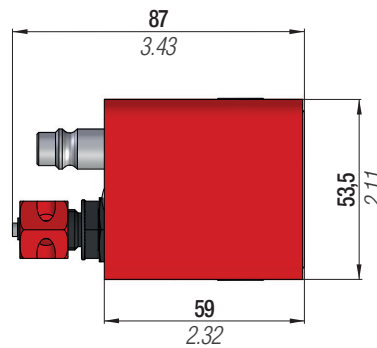
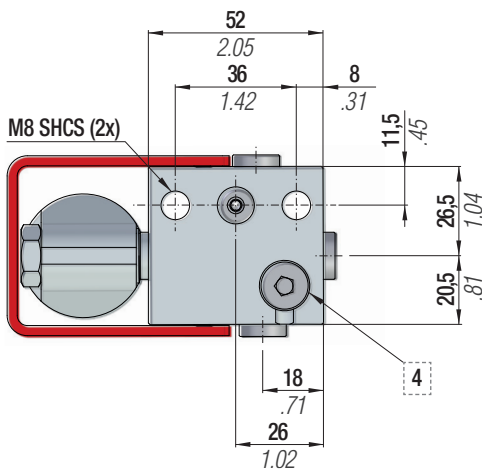

Technical data	
Measuring range	0 ÷ 600 bar / 8700 psi / 60 MPa
Visualization	3 digit display + 2 led
Resolution	1 bar, 10 psi, 1 MPa
Measurement unit	bar, psix10, MPa
Accuracy	±1,0% f.s., ±1 digit whichever is greater
Working temperature	0 ÷ 80°C / 176°F
Compatible fluids	Nitrogen
Battery	Maxell CR2032-3V, 220mAh
Material	Stainless steel/Aluminum alloy
Connection	G1/8"
Alarms	Low pressure (adjustable), High pressure (fixed), Sensor malfunction, Low battery
Battery lifetime	> 2000 readings
Degree of protection	IP65 when connected

1	Valvola di scarico Discharging valve Auslaßventil Valve de déchargement Válvula de descarga Válvula de descarga	2	Sensore di pressione EYE EYE Pressure Sensor Drucksensor EYE Capteur de pression EYE Sensor de presión EYE Sensor de pressão EYE	3	Innesto rapido di caricamento Cejn Quick coupling for charging Cejn Steckkegel Cejn Accouplement rapide mâle Cejn Acoplamiento rápido para carga Cejn União rápida para carregamento Cejn	4	Tappo di rottura sovrappressione Over pressure rupture plug Überdruck-Bruchstecker Bouchon de rupture de surpression Enchufe de ruptura de sobrepresión Plugue ruptura sobrepresão
---	--	---	---	---	--	---	---

ACCESSORIES



IT	Piastra di contrasto	Temperato
EN	Counter plate	Hardened
DE	Stellplatten	Gehärtet
FR	Plaques d'appui	Tempéré
ES	Placas de apoyo	Templado
PT	Placas de apoi	Temperado

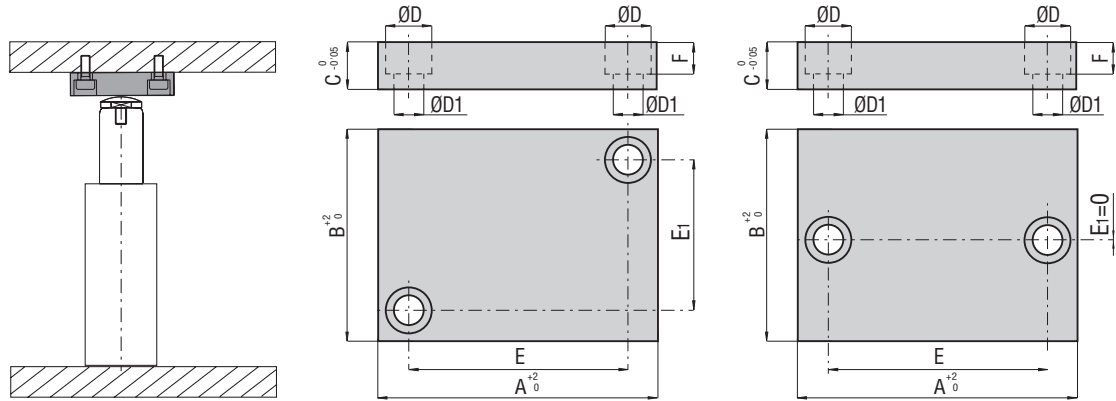

CODE	A		B		C		ØD		ØD1		E		E1		F		
	mm	inch	mm	inch	mm	inch	mm	inch	mm	inch	mm	inch	mm	inch	mm	inch	
39PA040040A ¹⁾⁵⁾	40	1.57	40	1.57	15	0.59	15	0.59	9	0.35	21	0.83	21	0.83	10	0.39	d ≤ 20 0.79
39PAB040040A ⁴⁾⁷⁾	40	1.57	40	1.57	12	0.47	11	0.43	7	0.28	24	0.94	24	0.94	7	0.28	d ≤ 20 0.79
39PAA040040A	40	1.57	40	1.57	15	0.59	11	0.43	7	0.28	24	0.94	24	0.94	7	0.28	d ≤ 20 0.79
39PA056056A ³⁾⁵⁾	56	2.20	56	2.20	20	0.79	18	0.71	11	0.43	32	1.26	32	1.26	13	0.51	d ≤ 36 1.42
39PA060060A ⁴⁾⁷⁾	60	2.36	60	2.36	15	0.59	15	0.59	9	0.35	40	1.57	40	1.57	9	0.35	d ≤ 36 1.42
39PAA060060A ⁶⁾	60	2.36	60	2.36	12	0.47	14	0.55	9	0.35	38	1.5	38	1.5	9	0.35	d ≤ 36 1.42
39PA070070A ¹⁾⁴⁾⁷⁾	70	2.76	70	2.76	15	0.59	15	0.59	9	0.35	50	1.97	50	1.97	9	0.35	d ≤ 60 2.36
39PA071071A ⁵⁾	71	2.80	71	2.80	20	0.79	18	0.71	11	0.43	48	1.89	48	1.89	13	0.51	d ≤ 60 2.36
39PA080080A ²⁾	80	3.15	80	3.15	16	0.63	15	0.59	9	0.35	62	2.44	0	0	10	0.39	d ≤ 65 2.56
39PAB090090A	90	3.54	90	3.54	12	0.47	15	0.59	9	0.35	64	2.52	64	2.52	9	0.35	d ≤ 80 3.15
39PAA090090A ¹⁾	90	3.54	90	3.54	15	0.59	15	0.59	9	0.35	70	2.76	70	2.76	9	0.35	d ≤ 80 3.15
39PA090090A ²⁾³⁾⁵⁾	90	3.54	90	3.54	20	0.79	18	0.71	11	0.43	67	2.64	67	2.64	13	0.51	d ≤ 80 3.15
39PAC090090A ⁶⁾	90	3.54	90	3.54	12	0.47	14	0.55	9	0.35	70	2.76	70	2.76	9	0.35	d ≤ 80 3.15
39PA100100A ²⁾	100	3.94	100	3.94	16	0.63	15	0.59	9	0.35	82	3.23	0	0	10	0.39	d ≤ 90 3.54
39PAA100100A ⁴⁾⁷⁾	100	3.94	100	3.94	20	0.79	18	0.71	11	0.43	74	2.91	74	2.91	11	0.43	d ≤ 90 3.54
39PAB100100A ⁶⁾	100	3.94	100	3.94	12	0.47	14	0.55	9	0.35	81	3.19	81	3.19	9	0.35	d ≤ 90 3.54
39PAA140140A ⁴⁾	140	5.51	140	5.51	20	0.79	18	0.71	11	0.43	110	4.33	110	4.33	11	0.43	d ≤ 130 5.12
39PA140140A ³⁾⁵⁾	140	5.51	140	5.51	20	0.79	18	0.71	11	0.43	110	4.33	110	4.33	13	0.51	d ≤ 130 5.12
39PA050025A ¹⁾⁵⁾	50	1.97	25	0.98	12	0.47	11	0.43	7	0.28	32	1.26	8	0.31	8	0.31	d ≤ 15 0.59
39PA050030B ⁵⁾	50	1.97	30	1.18	12	0.47	11	0.43	7	0.28	35	1.38	14	0.55	7	0.28	d ≤ 20 0.79
39PA055030A ¹⁾	55	2.17	30	1.18	12	0.47	11	0.43	7	0.28	40	1.57	14	0.55	8	0.31	d ≤ 20 0.79
39PA055032A ²⁾	55	2.17	32	1.26	16	0.63	15	0.59	9	0.35	37	1.46	0	0	10	0.39	d ≤ 20 0.79
39PA065050A ²⁾	65	2.56	50	1.97	16	0.63	15	0.59	9	0.35	47	1.85	0	0	10	0.39	d ≤ 36 1.42
39PA070035A ¹⁾⁵⁾	70	2.76	35	1.38	15	0.59	15	0.59	9	0.35	48	1.89	14	0.55	10	0.39	d ≤ 30 1.18
39PA075050A ¹⁾⁵⁾	75	2.95	50	1.97	15	0.59	15	0.59	9	0.35	56	2.2	30	1.18	10	0.39	d ≤ 36 1.42
39PA080060A ²⁾	80	3.15	60	2.36	16	0.63	15	0.59	9	0.35	62	2.44	0	0	10	0.39	d ≤ 55 2.17
39PAA085060A ⁵⁾	85	3.35	60	2.36	15	0.59	15	0.59	9	0.35	56	2.2	40	1.57	10	0.39	d ≤ 55 2.17
39PA085060A ¹⁾	85	3.35	60	2.36	15	0.59	15	0.59	9	0.35	66	2.6	40	1.57	10	0.39	d ≤ 55 2.17
39PA100080A ¹⁾⁵⁾	100	3.94	80	3.15	20	0.79	18	0.71	11	0.43	72	2.83	56	2.2	12	0.47	d ≤ 70 2.76
39PA110100A ⁵⁾	110	4.33	100	3.94	20	0.79	18	0.71	11	0.43	85	3.35	75	2.95	12	0.47	d ≤ 100 3.94

1) VDI 3003 2) Volvo 3) Renault 4) Volkswagen 5) FCA 6) Mercedes Benz 7) BMW

All dimensions in mm/inch

IT	Piastra di contrasto	Temperato
EN	Counter plate	Hardened
DE	Stellplatten	Gehärtet
FR	Plaques d'appui	Tempré
ES	Placas de apoyo	Templado
PT	Placas de apoi	Temperado

CODE	Ø A		Ø B		C		D		Ø E		Ø F		mm	inch
	mm	inch	mm	inch	mm	inch	mm	inch	mm	inch	mm	inch		
▲ 39PA050A ⁸⁾	50	1.97	29,6	1.17	15	0.59	10	0.39	15	0.59	9	0.35	d ≤ 15	0.59
▲ 39PA070A ⁸⁾	70	2.76	45,2	1.78	20	0.79	13	0.51	18	0.71	11	0.43	d ≤ 25	0.98
▲ 39PA094A ⁸⁾	94	3.70	67,8	2.67	20	0.79	13	0.51	18	0.71	11	0.43	d ≤ 50	1.97

8) Fiat

▲ Phasing out

CODE	Ø A		Ø B		C		D		Ø E		Ø F		mm	inch
	mm	inch	mm	inch	mm	inch	mm	inch	mm	inch	mm	inch		
39PA050B ⁵⁾	50	1.97	21	0.83	15	0.59	10	0.39	15	0.59	9	0.35	d ≤ 15	0.59
39PA070B ⁵⁾	70	2.76	32	1.26	20	0.79	13	0.51	18	0.71	11	0.43	d ≤ 25	0.98
39PA094B ⁵⁾	94	3.70	48	1.89	20	0.79	13	0.51	18	0.71	11	0.43	d ≤ 50	1.97

5) FCA

CODE	Ø A		Ø B		C		D		Ø E		Ø F		mm	inch
	mm	inch	mm	inch	mm	inch	mm	inch	mm	inch	mm	inch		
39PA098A ⁴⁾	98	3.86	73	2.87	13	0.51	20	0.79	20	0.79	13,5	0.53	d ≤ 50	1.97
39PA113A ⁴⁾	113	4.45	88	3.46	13	0.51	20	0.79	20	0.79	13,5	0.53	d ≤ 65	2.58
39PA128A ⁴⁾	128	5.04	103	4.06	13	0.51	20	0.79	20	0.79	13,5	0.53	d ≤ 80	3.15
39PA143A ⁴⁾	143	5.63	118	4.65	13	0.51	20	0.79	20	0.79	13,5	0.53	d ≤ 95	3.74

4) Volkswagen

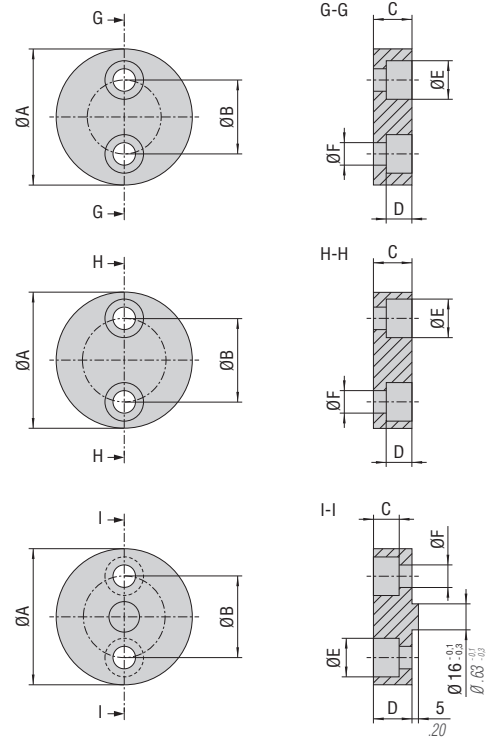

code FA 022

IT	Calotta	Temperato
EN	Thrust plates	Hardened
DE	Schaftkappe	Gehärtet
FR	Calotte pour tiges	Tempré
ES	Casquillo para vástagos	Templado
PT	Calote para embolo	Temperado

49 - 52 HRC

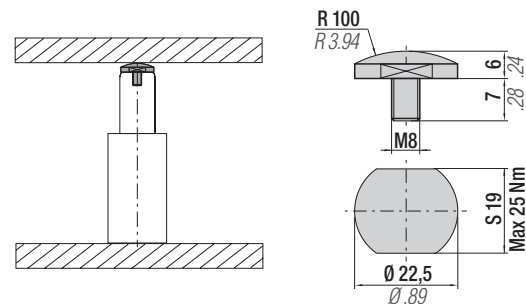

IT	Pressostato	Tensione di lavoro 48 V max	Normalmente aperto
EN	Pressure switch	Operating voltage 48 V max	Normally opened
DE	Druckwächter	Arbeitsspannung 48 V max	Normalerweise offen
FR	Pressostat	Tension d'utilisation 48 V max	Normalement ouvert
ES	Presostato	Tensión de trabajo 48 V max	Normalmente abierto
PT	Pressostato	Tensão de Trabalho 48 V max	Normalmente aberto

PRESSURE SWITCH

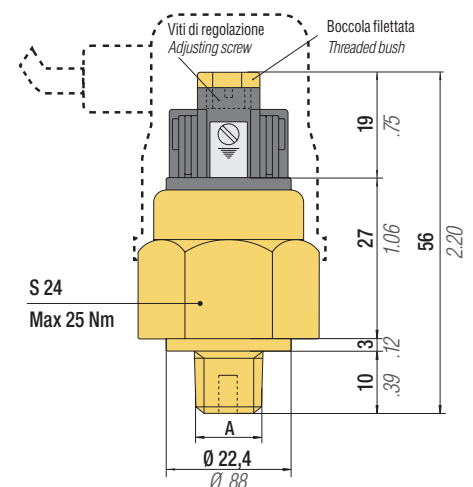
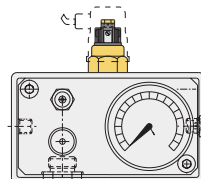

All dimensions in mm/inch

CODE	A	Range
PMM150A	1/8 " BSPT	50:150 bar
PMM300A	1/8 " BSPT	50:300 bar
PMM150A01	1/4 " BSPT	50:150 bar
PMM300A01	1/4 " BSPT	50:300 bar

ACCESSORIES



code 39DMB



- IT** Dispositivo completo per le operazioni di controllo, riduzione/aumento della pressione o caricamento di cilindri autonomi e sistemi collegati.
- EN** Complete device designed and built for checking operations, decreasing/increasing pressure, or charging self-contained gas springs and linked systems.
- DE** Komplette Vorrichtung zur Kontrolle Operationen, Verminderung / Erhöhung des Drucks, oder Ladung die Selbstständigen gasdruckfedern und verbundenen Systemen.
- FR** Dispositif complet pour les opérations de contrôle, réduction/augmentation de la pression ou chargement de cylindres autonomes et systèmes reliés.
- ES** Dispositivo completo para las operaciones de control, reducción/aumento de la presión o carga de cilindros autónomos y sistemas conectados.
- PT** Dispositivo completo para as operações de controle, redução/aumento da pressão ou carregamento dos cilindros autônomos e sistemas conectados.

Box content:

1	39DMCILA (1 pcs)
2	39DMCPVA (1 pcs) included 39IR01A (1 pcs)
3	ADM01 (1 pcs) - ADM02 (1 pcs) - ADM03 (1 pcs) - ADM04 (1 pcs) - ADM05 (1 pcs) - ADM06 (1 pcs) - ADM08 (1 pcs) - ADM09 (1 pcs) - ADM12 (1 pcs) - ADM13 (1 pcs) - ADM14 (1 pcs) - ADM15 (1 pcs) - ADM16 (1 pcs)
-	Declaration of CE conformity - User manual

Installation Example

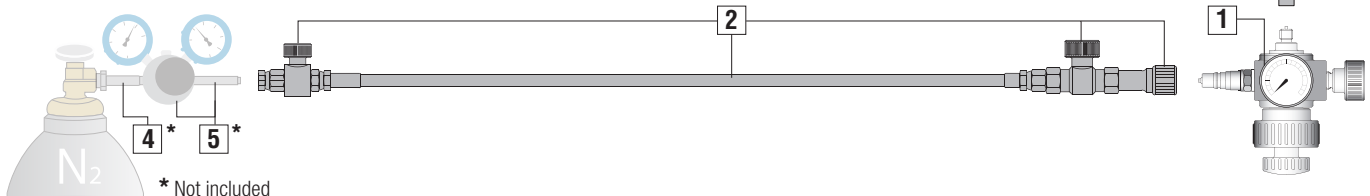

- 4* Attacco per bombola - Connection for bottle - Ansatz für die Flasche - Décapage pour bombonne - Conexión para bombona - Ataque a Bottle p.126
- 5* Riduttore di pressione - Pressure reducer - Druckminderer - Réducteur de pression - Reductor de presión - Redutor de pressão p.127

code 39DMCILA



- IT** Manometro 0 ÷ 315 bar - 2 manopole - valvola di riduzione/scarico pressione - adattatore fisso G1/8" - attacco rapido maschio Cejn.
- EN** 0 ÷ 315 bar gauge - 2 hand knobs- pressure limitation/discharging valve - G1/8" built in adapter - quickfit male Cejn.
- DE** Manometer 0 ÷ 315 bar - 2 Drehknopfs - Entlüftungsventil - fester Adapter G1/8" - Schnellverschlusskupplung Stecker Cejn.
- FR** Manomètre 0 ÷ 315 bar - 2 poignées - soupape de réduction/déchargement pression - Adaptateur fixe G1/8" - enclenchement instantané mâle Cejn.
- ES** Manómetro 0 ÷ 315 bar - 2 manillas - válvula de reducción/descarga de presión - adaptador fijo G1/8" - enchufe rápido macho Cejn.
- PT** Manómetro 0 ÷ 315 bar/psi - 2 manoplas - válvula de redução/descarga pressão - adaptador fixo G1/8" - engate rápido macho Cejn.

code	ith Mt hose
39DMCPVA	3 mt
39DMCPVA-5M	5 mt



- IT** mt di tubo - attacco rapido femmina Cejn - valvola ON/OFF - valvola di scarico tubo - 1 innesto rapido supplementare (cod. 39IR01A).
- EN** Mt high pressure hose- quickfit female Cejn- shut-off valve- hose release valve -additional quick coupling (cod. 39IR01A).
- DE** Meter Schlauch- Schnellverschlusskupplung Muffe Cejn- Sperrventil- Rohr Ablassventil- 1 zusätzliche Schnellverschluss Kupplung (im. 39IR01A).
- FR** m de tuyau – enclenchement instantané femelle Cejn – soupape ON/OFF – soupape de déchargement tuyau - 1 enclenchement instantané supplémentaire (cod. 39IR01A).
- ES** mt de tubo - enchufe rápido hembra Cejn - válvula ON/OFF - válvula de descarga tubo - 1 enchufe rápido suplementario (cod. 39IR01A).
- PT** mt de tubo – engate rápido fêmea Cejn - válvula ON/OFF - válvula de descarga tubo - 1 engate rápido suplementar (cod. 39IR01A).

code 39QDFV02 for M6 thread
 code 39QDFV03 for M6 thread
 code 39QDFV04 for M4 thread
 code 39QDFV05 for M5 thread
 code 39QDFV06 for M8 thread
 code 39QDFV07 for M10 thread
 code 39QDFV08 for M12 thread

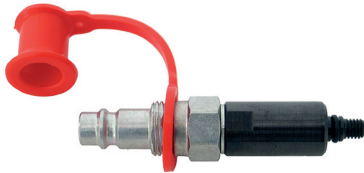

- IT** Adattatore per caricamento diretto con innesto rapido maschio Cejn.
- EN** Cejin male quick fit adapter for direct charging.
- DE** Adapter für direkt Ladung mit Schnellverschlusskupplung Stecker Cejin.
- FR** Adaptateur direct pour le chargement avec enclenchement instantané mâle Cejin.
- ES** Adaptador para carga directa con enchufe rápido macho Cejin.
- PT** Adaptador direto para a carga com engate rápido macho Cejin.

tab below.

Code	39QDFV04	39QDFV05	39QDFV02	39QDFV03	39QDFV06	39QDFV07	39QDFV08
Modello	NT 25	NMS16	NML25	NCS25	NML38	NML50	NML75
Model		NMS19	NML32	NCS32	NC32	NML63	
Modell			NCS19	NCS32.2	NC38		
Model			NMS25	NCS38	NMX38		
Modelo			NMX19	NCS50			
Modelo			NMX25	NCS63			
Modelo			NMX32	NT32			
			NMX50				
			NMC19				
			NMC25				
A	M4	M5	M6	M6	M8	M10	M12
Ø D	16	16	16	16	16	16	18,5
S	15	15	15	15	15	15	17
Code	ADM16	ADM12	ADM08	ADM09	ADM13	ADM14	ADM15

code ADM...

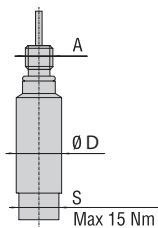

- IT** Adattatore per dispositivo 39DMCILA.
- EN** Adapter for 39DMCILA device.
- DE** Adapter für 39DMCILA Vorrichtung.
- FR** Adaptateur pour dispositif 39DMCILA.
- ES** Adaptador para dispositivo 39DMCILA.
- PT** Adaptador para dispositivo 39DMCILA.

tab above.

ACCESSORIES



IT Dispositivo di scaricamento.

DE Ablassvorrichtung.

ES Dispositivo de descarga.

EN Discharging device.

FR Dispositif de déchargement.

PT Dispositivo de descarga.

code 39DDS03A

Thread	M6	
Model	NML NCS NMS	NMX NMC NT

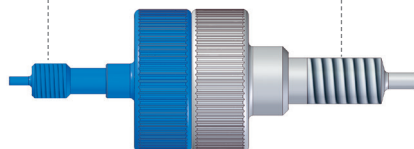

Thread	M8	
Model	NML NMX	NC

code 39DDS04A

Thread	M10	
Model	NML	

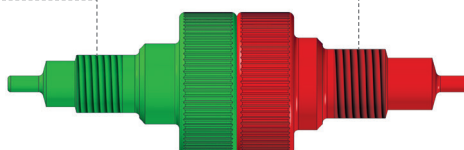

Thread	M12	
Model	NML	

code 39DDS05A

Thread	M4	
Model	NT	



Thread	M5	
Model	NMS	

code 58UT029A

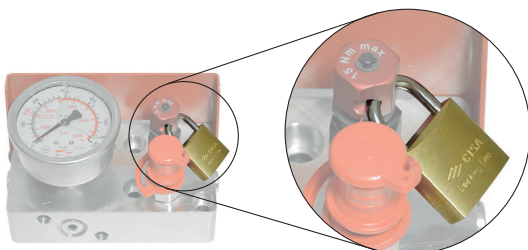

IT Lucchetto blocca valvola di scarico.

EN Padlock for discharge valve.

DE Vorhängeschloss für das Ablassventil.

FR Verrou pour soupape de décharge.

ES Candado de bloqueo de la válvula de descarga.

PT Cadeado para tramcar a valvula de descarregamento.

HOW TO USE IT

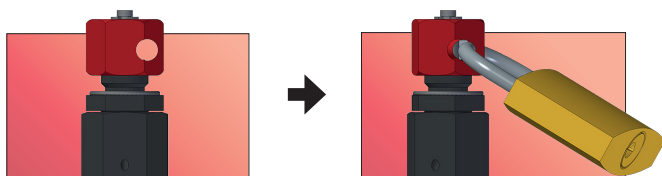

WHY TO USE IT

IT Per impedire caricamenti **NON autorizzati** durante la manutenzione.

EN To prevent **UNauthorized** charging during maintenance.

DE Um **unbefugtes** Befüllen zu verhindern bei der Wartung.

FR Pour empêcher le chargement **NON autorisé** pendant l'entretien.

ES Para impedir cargas **NO autorizadas** durante el mantenimiento.

PT Para impedir o carregamento **SEM autorização** durante a manutenção.

BENEFITS

IT Manutenzioni più sicure e con meno incidenti.

EN Safer maintenance and less accidents.

DE Mehr Sicherheit bei der Wartung und weniger Unfälle.

FR Un entretien plus sûr et moins d'accidents.

ES Mantenimientos más seguros y con menos accidentes.

PT Manutenção mais segura e com menos acidentes.

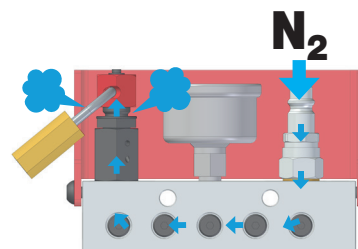

code 39SP01B

- IT** Sensore di pressione con display digitale. Collegando direttamente il sensore di pressione al controllo pressa è possibile impostare un range di lavoro desiderato al di fuori del quale il dispositivo invierà un segnale di allarme.
- EN** Pressure sensor with digital display. By connecting the pressure sensor directly to the press control, it is possible to set a desired working range outside which the unit sends an alarm signal.
- DE** Drucksensor mit Digitalanzeige. Wenn man den Drucksensor direkt an die Pressensteuerung anschließt, ist es möglich einen gewünschten Arbeitsbereich einzustellen, außerhalb dessen das Gerät ein Alarmsignal sendet.
- FR** Capteur de pression avec affichage numérique. En connectant le capteur de pression directement au système de contrôle de la presse, il est possible de définir une plage de fonctionnement souhaitée en dehors de laquelle l'unité envoie un signal d'alarme.
- ES** Sensor de presión con pantalla digital. Conectando directamente el sensor de presión al control de la prensa, es posible establecer un rango de trabajo deseado fuera del cual el dispositivo enviará una señal de alarma.
- PT** Sensor de pressão com display digital. Conectando o painel ao comando da prensa, é possível determinar uma faixa de trabalho, que qualquer alteração desta faixa, o painel emitira um alarme.

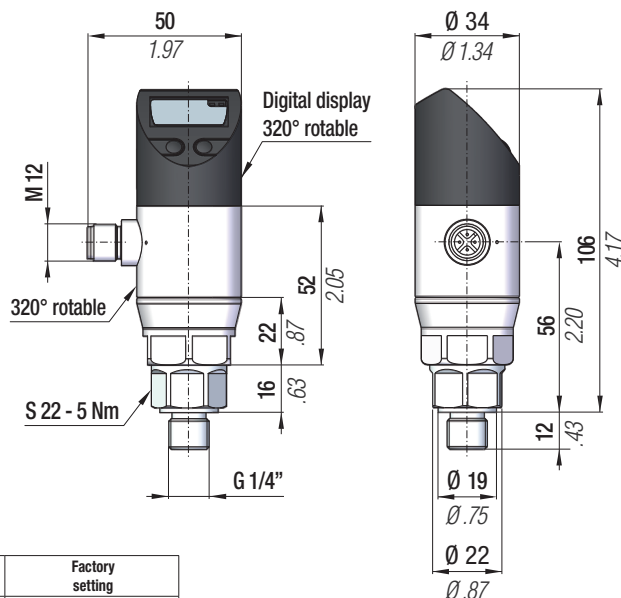

Technical data	
Electrical connector type	M12x1 - Male (4-pin), A-coded
Pressure connection	G 1/4" DIN 3852
Nominal pressure	0 - 600 bar
Burst pressure	1570 bar
Operating voltage U _o	18...36 V DC
Output current max.	150 mA
Current draw max	50 mA
Switching frequency f	170 Hz
Temperature range	- 25°C... + 85°C
Degree of protection as per IEC 60529	IP67 when connected

Electrical connections	Pin number	Wire color	Factory setting
Supply +	1	Brown	-
Supply -	3	Blue	-
Out 1	4	Black	PNP Switching output / IO-link
Out 2	2	White	PNP Switching output

Electrical connections	Programmable settings
Out 1	PNP-NPN Switching output / IO-Link
Out 2	PNP-NPN Switching output / 4...20mA - 0-10V analog output

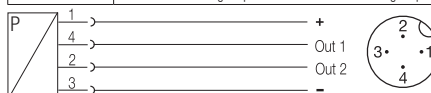

Always depressurize and disconnect sensors from the power supply before establishing an electrical connection.

- IT** Sistema digitale alimentato a batteria per il controllo della pressione di impianti collegati. Il sistema visualizza la pressione quando viene premuto il tasto e indica se accettabile attraverso i led rosso/verde (valore di soglia impostabile). Display in bar, psi o MPa.
- EN** Battery-powered digital system for pressure control of linked systems. The system displays the pressure when the key is pressed and indicates if it is acceptable through the red/green LEDs (settable threshold value). Display in bar, psi or MPa.
- DE** Batteriebetriebenes digitales System zur Druckregelung von angeschlossenen Systemen. Das System zeigt den Druck beim Drücken der Taste an und zeigt über die roten/grünen LEDs an, ob dieser akzeptabel ist (einstellbarer Schwellenwert). Anzeige in bar, psi oder MPa.
- FR** Système numérique alimenté par batterie pour le contrôle de la pression des systèmes connectés. Le système affiche la pression à l'appui sur la touche et indique si elle est acceptable par les leds rouges/vertes (valeur seuil paramétrable). Affichage en bar, psi ou MPa.
- ES** Sistema digital alimentado por batería para el control de presión de sistemas conectados. El sistema muestra la presión cuando se presiona la tecla e indica si es aceptable a través de los LED rojo/verde (valor umbral configurable). Visualización en bar, psi o MPa.
- PT** Sistema digital alimentado por bateria para controle de pressão de sistemas conectados. O sistema exibe a pressão quando a tecla é pressionada e indica se ela é aceitável através dos LEDs vermelho/verde (valor limite configurável). Exibição em bar, psi ou MPa.

code 39SPB02A

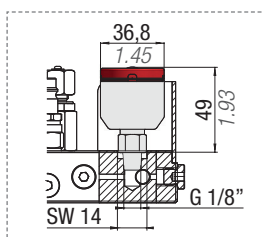

EYE PRESSURE SENSOR



Technical data	
Measuring range (relative):	0 ÷ 600 bar / 8700 psi / 60 MPa
Visualization:	3 digit display + 2 led
Measurement unit:	bar, psix10, MPa
Resolution:	1 bar, 10 psi, 1 MPa
Accuracy:	±2,0% f.s. or ±1 digit, whichever is greater
Working temperature:	0 ÷ 80°C / 176°F
Compatible fluids:	Nitrogen
Battery:	Maxell CR2032-3V, 220mAh
Material:	Stainless steel/Aluminum alloy
Connection:	G 1/8
Alarms:	Min. pressure (adjustable), Pressure over 450 bar / 6530 psi / 45 MPa, Sensor malfunction, Low battery
Battery lifetime:	> 2000 readings
Protection Grade:	IP65 when connected
39SPB02A Suitable for:	CP01A, CP07A, CP10A, CP12A, MCPC, CP19A

ACCESSORIES



IT Tappo di sicurezza sovrappressione CE.

EN Overpressure safety plug CE.

DE Überdruck Sicherheitsstecker CE.

FR Bouchon de sécurité surpression CE.

ES Tapón de seguridad por sobrepresión CE.

PT Bujão de segurança sobrepressão CE.

code: 39TS300

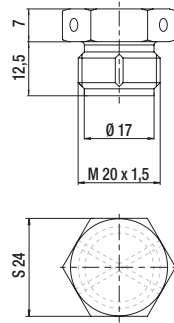

Burst pressure
@20°C 300bar / 4350 psi

code: 39TS360

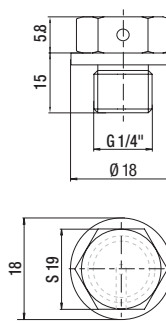

Burst pressure
@20°C 360bar / 5220 psi

code: 39TS460

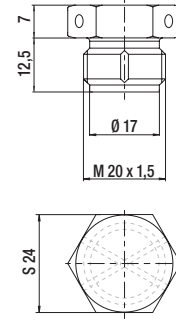

Burst pressure
@20°C 460bar / 6670 psi

IT Chiave dinamometrica con accessori.

EN Torque wrench with accessories.

DE Drehmomentschlüssel mit Zubehör.

FR Clé dynamométrique avec ses accessoires.

ES Llave dinamométrica con accesorios.

PT Chave dinamométrica com acessórios.



code	Nm
58UT025A	4 - 40



code	58UT013A
code	58UT013A

code	size	
	mm	inch
58UT009A	3	0.12
58UT010A	4	0.16
58UT011A	6	0.24
58UT012A	8	0.31



code	size	
	mm	inch
58UT014A	10	0.39
58UT015A	12	0.47
58UT016A	14	0.55
58UT017A	15	0.59
58UT018A	17	0.67
58UT019A	18	0.71
58UT020A	19	0.75
58UT065A	14,3	9/16

ORDERING EXAMPLE

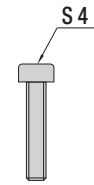

58UT025A
+
58UT013A
+
58UT010A

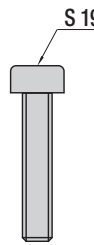

58UT025A
+
58UT020A

WARNING PLATE

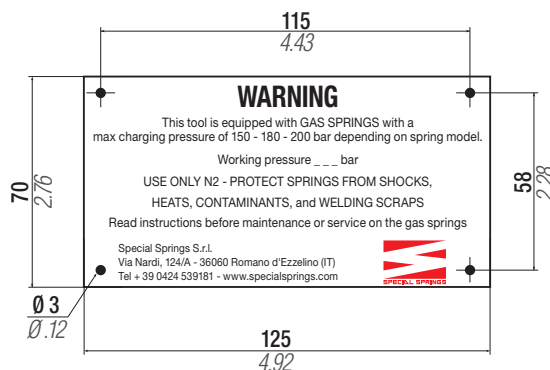

- IT** Targhetta
- EN** Advice plate
- DE** Schilder
- FR** Plaquettes
- ES** Placas
- PT** Etiquetas

Codice	39 TAR-I
Code	39 TAR-GB
Bestellnummer	39 TAR-D
Référence	39 TAR-F
Codigo	39 TAR-E
Codigo	39 TAR-P

All dimensions in mm/inch



code	Service tools	Service accessories
CMCA	✓	✓

- IT** Set completo per manutenzione cilindri.
- EN** Service tools and Accessories for gas spring maintenance.
- DE** Komplettes Wartungsset für Gasdruckfedern.
- FR** Kit d'entretien complet pour ressorts à gaz.
- ES** Kit de mantenimiento completo para resortes de gas.
- PT** Kit de manutenção completo para cilindros.



code	Service tools	Service accessories
CMCTA	✓	✗

- IT** Solo set utensili per manutenzione cilindri.
- EN** Service tools for gas spring maintenance.
- DE** Nur Werkzeugset zur Wartung von Gasdruckfedern.
- FR** Set d'outils pour l'entretien de ressorts à gaz.
- ES** Set de herramientas para mantenimiento de resortes de gas.
- PT** Conjunto de ferramentas para manutenção dos cilindros.



code	Service tools	Service accessories (specific family of gas springs)
CMC - ...	✗	✓

- IT** Set accessori per determinata famiglia di cilindri (es. CMCA - NML 38).
- EN** Service accessories for maintenance of a specific gas spring model (ex. CMCA - NML 38).
- DE** Zubehörset für bestimmte Zylindertypen (z. B. CMCA - NML 38).
- FR** Jeu d'accessoires pour une famille donnée de cylindres (ex.: CMCA - NML 38).
- ES** Set de accesorios para una determinada familia de cilindros (p.ej. CMCA - NML 38).
- PT** Acessórios de conjunto para determinada família de cilindros (ex. CMCA - NML 38).

code 58CD01



- IT** Cacciavite dinamometrico per valvola unidirezionale.
- EN** Torque screwdriver for one-way valve.
- DE** Drehmomentschrauber für Rückschlagventil.
- FR** Tournevis dynamométrique pour valve anti-retour.
- ES** Destornillador dinámico para válvula anti-retorno.
- PT** Chave torquimétrica para válvula de retenção.

code 59VU02A



- IT** Valvola unidirezionale (esclusi NCS19, NCS25, NMS16/19/25, NMX25, NMC19/25).
- EN** One-way valve (excluding NCS19, NCS25, NMS16/19/25, NMX25, NMC19/25).
- DE** Rückschlagventil (außer NCS19, NCS25, NMS16/19/25, NMX25, NMC19/25).
- FR** Valve anti-retour (à l'exclusion de NCS19, NCS25, NMS16/19/25, NMX25, NMC19/25).
- ES** Válvula anti-retorno (excepto NCS19, NCS25, NMS16/19/25, NMX25, NMC19/25).
- PT** Válvula de retenção (excluindo NCS19, NCS25, NMS16/19/25, NMX25, NMC19/25).

code 39PM02A



- IT** Pressa manuale per assemblaggio stelo, boccia e anello di ritegno a C.
- EN** Table manual press for assembly of rod, bushing and retaining C-ring.
- DE** Manuelle Presse zur Montage von Kolbenstange, Buchse und Sprengring.
- FR** Presse manuelle pour l'assemblage de la tige, douille et bague d'étanchéité en C.
- ES** Prensa manual para ensamblaje vástago, casquillo y anillo de retención a C.
- PT** Prensa manual para ensambladura haste, bucha e anel de retenção a C.

Product Suggestion



- IT** Spray rivelatore di fughe.
- EN** Gas detector.
- DE** Gasdetektor Spray.
- FR** Spray détecteur de fuites de gaz.
- ES** Spray detector de escapes de gas.
- PT** Spray revelador de fugas de gás.

Potential supplier
www.tecnogas.net

ACCESSORIES



- IT** Attacco per bombola.
- EN** Connection for bottle.
- DE** Ansatz für die Flasche.
- FR** Décapage pour bombonne.
- ES** Adaptador para bombona
- PT** Ataque a Bottle.

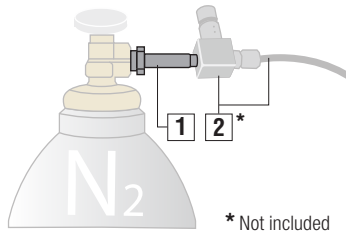









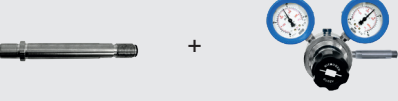
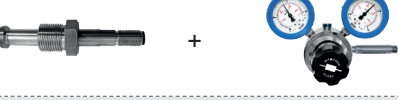
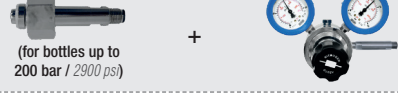



* Not included

Installation Example

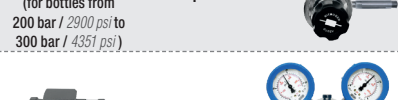
<p>1 Attacco per bombola Connection for bottle Ansatz für die Flasche Décapage pour bombonne Adaptador para bombona Ataque a Bottle</p>	<p>2* Tubo collegamento bombola con valvola di scarico Connecting hose from the bottle to the valve discharging Verbindungsschlauch der Flasche mit Auslassventil Tube pour la connexion bombonne avec valve de décharge Tubo de conexión a bombona con válvula de descarga Tubo de ligação Frasco com a válvula de descarga</p>
--	---

code	X	Box content	Country
47TB	W 21,7x1/14" - Male - ISO 228		IT - Italy PT - Portugal
47TB01	-		CN - China KR - South Korea
47TB02	W 22,5 - 14 t.p.i JIS B 8246 - Male		JP - Japan ID - Indonesia
47TB03	W 24,32x1/14" - DIN 477 - 1 Female (for bottles up to 200 bar / 2900 psi)		DE - Germany
47TB04	d 21,7x1,814 - NF E 29 - 650 - Female		FR - France
47TB05	G 5/8" - ISO 228 - Male		IN - India
47TB06	G 3/4" - ISO 228 - Female		RU - Russia
47TB07	0.960 - 14 NGO - RH - Male - CGA NO. 580 (for bottles up to 206 bar / 3000 psi)		US - United States
47TB08	1.040 - 14 NGO - RH - Male - CGA NO. 680 (for bottles from 206 bar / 3000 psi to 324 bar / 4700 psi)		US - United States
47TB09	W 21,7x1/14 - Female		ES - Spain PT - Portugal
47TB10	W 24,32x1/14 - DIN 477 - 1 - Female		KR - South Korea
47TB11	W 30x2 - DIN 477 - 5 - Female (for bottles from 200 bar / 2900 psi to 300 bar / 4351 psi)		DE - Germany
47TB12	G 3/4A - RH IS 3224 - Female		IN - India
47TB13	W 22 - 14 t.p.i JIS B 8246 - Male		JP - Japan
47TB15	G 5/8" - ISO 228 - Male		UK - United Kingdom

code	Box content 1 + 2	Country
39RHP (max. inlet pressure 300 bar / 4350 psi)		IT - Italy PT - Portugal
39RHP01 (max. inlet pressure 300 bar / 4350 psi)		CN - China KR - South Korea
39RHP02 (max. inlet pressure 300 bar / 4350 psi)		JP - Japan ID - Indonesia
39RHP03 (max. inlet pressure 200 bar / 2900 psi) <small>(for bottles up to 200 bar / 2900 psi)</small>		DE - Germany
39RHP04 (max. inlet pressure 300 bar / 4350 psi)		FR - France
39RHP05 (max. inlet pressure 300 bar / 4350 psi)		IN - India
39RHP06 (max. inlet pressure 300 bar / 4350 psi)		RU - Russia
39RHP07 (max. inlet pressure 300 bar / 4350 psi) <small>(for bottles up to 206 bar / 3000 psi)</small>		US - United States
39RHP08 (max. inlet pressure 300 bar / 4350 psi) <small>(for bottles from 206 bar / 3000 psi to 324 bar / 4700 psi)</small>		US - United States
39RHP09 (max. inlet pressure 300 bar / 4350 psi)		ES - Spain PT - Portugal
39RHP10 (max. inlet pressure 300 bar / 4350 psi)		KR - South Korea
39RHP11 (max. inlet pressure 300 bar / 4350 psi) <small>(for bottles from 200 bar / 2900 psi to 300 bar / 4351 psi)</small>		DE - Germany
39RHP12 (max. inlet pressure 300 bar / 4350 psi)		IN - India
39RHP13 (max. inlet pressure 300 bar / 4350 psi)		JP - Japan
39RHP15 (max. inlet pressure 300 bar / 4350 psi)		UK - United Kingdom

IT Riduttore di pressione completo di attacco bombola per controllare e ridurre la pressione.

EN Pressure reducer complete with gas spring connection to control and reduce the pressure.

DE Druckminderer komplett mit Flaschen-Anschluss, um den Druck zu kontrollieren und verringern.

FR Réducteur de pression complet avec jonction de bouteille pour contrôler et réduire la pression.

ES Reductor de presión completo con adaptador a bombona para controlar y reducir la presión

PT Redutor de pressão completo com engate para controlar e reduzir a pressão.

Example code: 39RHP

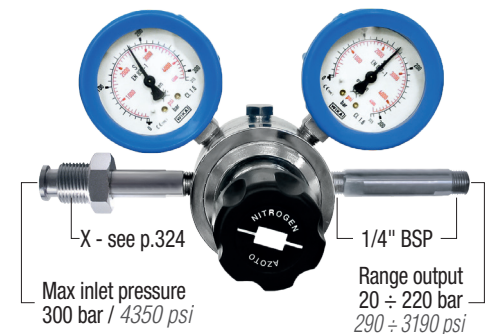

Installation Example

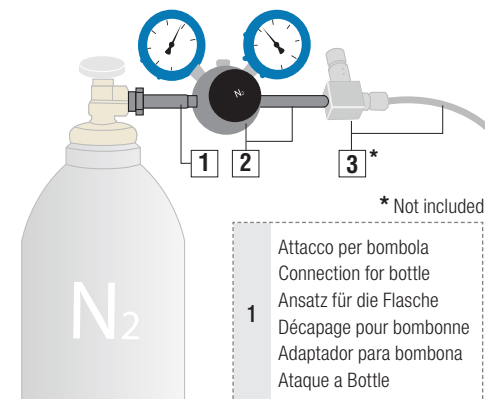

Riduttore di pressione max. 300 bar / 4350 psi

Pressure reducer max. 300 bar / 4350 psi

Druckminderer max. 300 bar / 4350 psi

Réducteur de pression max. 300 bar / 4350 psi

Reductor de presión max. 300 bar / 4350 psi

Redutor de pressão max. 300 bar / 4350 psi

Tubo collegamento bombola con valvola di scarico

Connecting hose from the bottle to the valve discharging

Flaschen-Verbindungsschlauch mit Auslassventil

Tube pour la connexion bombonne avec valve de décharge

Tubo de conexión a bombona con válvula de descarga

Tubo de ligação Frasco com a válvula de descarga

ACCESSORIES

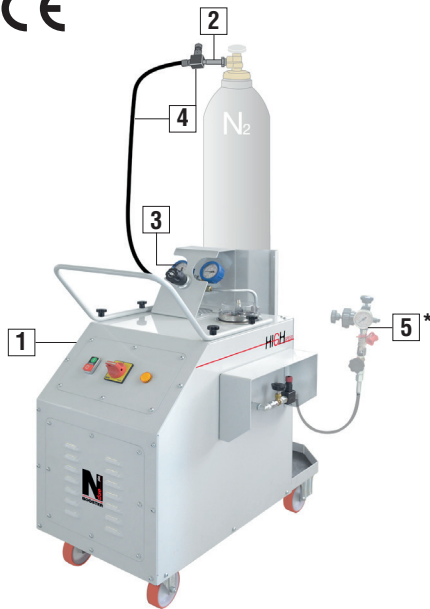

* Not included

code	Box content 1 + (2 + 3) + 4	Power supply	Country	Kg	
39NCU01B	Booster + 39RHP	220 ÷ 240 VAC 50 ÷ 60 Hz	Italy - Portugal	105 kg	231 lbs
39NCU10B	Booster + 39RHP01	220 ÷ 240 VAC 50 ÷ 60 Hz	China - Korea	105 kg	231 lbs
39NCU11B	Booster + 39RHP02	220 ÷ 240 VAC 50 ÷ 60 Hz	Indonesia	105 kg	231 lbs
39NCU12B	Booster + 39RHP03	220 ÷ 240 VAC 50 ÷ 60 Hz	Germany	105 kg	231 lbs
39NCU13B	Booster + 39RHP04	220 ÷ 240 VAC 50 ÷ 60 Hz	France	105 kg	231 lbs
39NCU14B	Booster + 39RHP05	220 ÷ 240 VAC 50 ÷ 60 Hz	India	105 kg	231 lbs
39NCU15B	Booster + 39RHP06	220 ÷ 240 VAC 50 ÷ 60 Hz	Russia	105 kg	231 lbs
39NCU22B	Booster + 39RHP07	120 VAC 50 ÷ 60 Hz	USA	116 kg	255 lbs
39NCU23B	Booster + 39RHP08	120 VAC 50 ÷ 60 Hz	USA	116 kg	255 lbs
39NCU29B	Booster + 39RHP09	220 ÷ 240 VAC 50 ÷ 60 Hz	Spain	105 kg	231 lbs
39NCU31B	Booster + 39RHP10	220 ÷ 240 VAC 50 ÷ 60 Hz	Korea	105 kg	231 lbs
39NCU32B	Booster + 39RHP11	220 ÷ 240 VAC 50 ÷ 60 Hz	Germany	105 kg	231 lbs
39NCU33B	Booster + 39RHP12	220 ÷ 240 VAC 50 ÷ 60 Hz	India	105 kg	231 lbs
39NCU34B	Booster + 39RHP13	100 VAC 50 ÷ 60 Hz	Japan	120 kg	265 lbs
39NCU40B	Booster + 39RHP14	220 ÷ 240 VAC 50 ÷ 60 Hz	Portugal	105 kg	231 lbs
39NCU41B	Booster + 39RHP02	100 VAC 50 ÷ 60 Hz	Japan	120 kg	265 lbs
39NCU42B	Booster + 39RHP15	220 ÷ 240 VAC 50 ÷ 60 Hz	United Kingdom	105 kg	231 lbs

1	<p>Booster carrellato per il caricamento di grandi volumi di azoto, con azionamento elettro-idraulico per la massima velocità Wheeled Booster for the filling of large volumes of nitrogen, with electro-hydraulic start-up for the maximum speed Ein fahrbarer Booster für die Ladung großer Mengen von Stickstoff, mit elektrohydraulischem Antrieb für Maximalgeschwindigkeit. Booster à chariot, pour la charge de grands volumes d'azote, avec actionnement électro-hydraulique pour la vitesse maximum Booster con ruedas para la carga de grandes volúmenes de nitrógeno con accionamiento electro-hidráulico para máxima rapidez. Booster rodado para o carregamento de grandes volumes de nitrogênio com acionamento eletro-hidráulico para a velocidade máxima</p>	2	<p>Attacco per bombola Connection for bottle Ansatz für die Flasche Décapage pour bombonne Adaptador para bombona Ataque a Bottle</p>	<p>Direct to N2 bottle p. 126</p>	
3	<p>Riduttore di pressione Pressure reducer Druckminderer Réducteur de pression Reductor de presión Redutor de pressão</p>	4	<p>Tubo collegamento bombola con valvola di scarico Connecting hose from the bottle to the valve discharging Verbindung Schlauche des Flasche mit Auslassventil Tube pour la connexion bombonne avec valve de décharge Tubo de conexión a bombona con válvula de descarga Tubo de ligação Frasco com a válvula de descarga</p>	5*	<p>Dispositivo di caricamento DMA Charging device DMA Ladung Vorrichtung DMA Dispositif de charge DMA Dispositivo de carga DMA Dispositivo de carregamento de DMA</p>

IT Caratteristiche - vantaggi

- Massima sicurezza, minimi tempi di caricamento
 - Arresto automatico alla pressione impostata
 - Segnale luminoso di fine ciclo
 - Valvola di sicurezza per sovrappressione
 - Pompa elettrica
 - Pressione di uscita regolabile
 - Telaio carrellato con alloggiamento bombola N2
 - Utilizzare con set di caricamento DMA (opzionale)
- La fornitura comprende:** Unità booster, 3 mt di tubo per collegamento a bombola o riduttore di pressione + attacco per bombola.

FR Caractéristiques - avantages

- Sécurité maximum, temps de chargement minimum
 - Arrêt automatique à la pression établie
 - Signal lumineux de fin de cycle
 - Valve de sécurité pour la surpression
 - Pompe électrique
 - Pression de sortie réglable
 - Châssis à chariot avec logement de bonbonne N2
 - À utiliser avec le set de chargement DMA (en option)
- La fourniture inclut:** Unité booster, 3 mt de tube pour la connexion à la bombonne ou au réducteur de pression + Décapage bombonne.

EN Features - advantages

- Maximum safety, low charging time
 - Automatic stop when the set pressure is reached
 - Light indicator of cycle end
 - Safety valve for overpressure
 - Electric pump
 - Adjustable output pressure
 - Wheeled cart with N2 bottle housing
 - To be used with charging set DMA (optional)
- The supply includes:** Booster unit, 3 mt hose for connecting the bottle or pressure reducer + bottle connection.

ES Características - Ventajas

- Máxima seguridad, tiempo mínimo de carga
 - Parada automática en la presión elegida
 - Señal luminosa de final de ciclo
 - Válvula de seguridad para sobrepresión
 - Bomba eléctrica
 - Presión de salida regulable
 - Chasis sobre ruedas y alojamiento para botella de N2
 - Utilizar combinado con set de carga DMA (opcional)
- El suministro incluye:** Unidad Booster, tubo de 3 mt para conexión a la bombona o al reductor de presión + adaptador para Bombona.

DE Eigenheiten - Vorteile

- Maximale Sicherheit, minimale Befüllzeiten
 - Automatisches Anhalten beim Erreichen des Drucks
 - Leuchtsignal bei Zyklusende
 - Überdruck-Sicherheitsventil
 - Elektrische Pumpe
 - Einstellbarer Output-Druck
 - Fahrbares Gestell mit Ablagefach für N2-Gasflasche
 - Zum Einsatz mit der DMA Ladevorrichtung (optional)
- Die Lieferung beinhaltet:** Booster Gerät, 3 Meters Schlauch für den Anschluss zur Flasche oder zum Druckminderer + Ansatz für die Flasche.

PT Características - Benefícios

- Máxima segurança, tempos de carregamento mais baixos
 - Paragem automática quando atingida a pressão especificada
 - Sinal luminoso de fim de ciclo
 - Válvula de segurança activa sobrepresão
 - Bomba eléctrica
 - Saída de pressão ajustável
 - Quadro rodado com alojamento para tank N2
 - Utilizado com o conjunto de carregamento DMA (opcional)
- O fornecimento inclui:** Unidade Booster, 3 mt tubo para ligação ao cilindro de azoto ou de reductor de pressão + Ataque a Bottle.

0,85 kW see power supply	210 bar 3045 psi	30 bar 435 psi	1300 NL / min *	0 - 45 °C 32 - 113 °F	600 x 560 x 680 mm 24 x 22 x 27 inch	See tab.

* Il rendimento volumetrico varia in funzione di PN₂ - The volumetric efficiency varies according to PN₂ - Der Liefergrad ändert sich in Abhängigkeit vom PN₂
Le rendement volumétrique varie en fonction de PN₂ - El rendimiento volumétrico varía en función de PN₂ - O rendimento volumétrico varia em função da PN₂

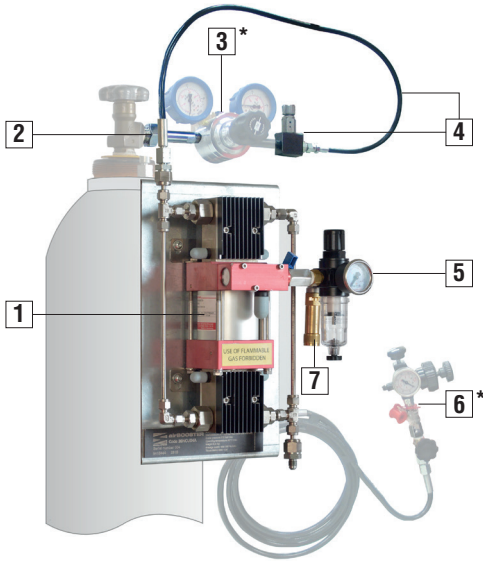

* Not included

To N2 bottle with pressure reducer
 p. 127

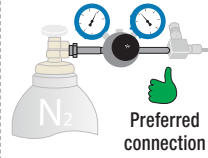

Direct to N2 bottle
 p. 126



code	Box content 1 + 2	Country
39NCU03A	AirBooster + 47TB	Italy - Portugal
39NCU04A	AirBooster + 47TB01	China - Korea
39NCU05A	AirBooster + 47TB02	Japan - Indonesia
39NCU06A	AirBooster + 47TB03	Germany
39NCU07A	AirBooster + 47TB04	France
39NCU08A	AirBooster + 47TB05	India
39NCU09A	AirBooster + 47TB06	Russia
39NCU26A	AirBooster + 47TB07	USA
39NCU27A	AirBooster + 47TB08	USA
39NCU28A	AirBooster + 47TB09	Spain
39NCU35A	AirBooster + 47TB10	Korea
39NCU36A	AirBooster + 47TB11	Germany
39NCU37A	AirBooster + 47TB12	India
39NCU38A	AirBooster + 47TB13	Japan
39NCU39A	AirBooster + 47TB14	Portugal
39NCU43A	AirBooster + 47TB15	UK

1	Booster portatile compatto per caricamento azoto con azionamento pneumatico Compact portable booster for the filling of nitrogen, with pneumatic start-up Ein kompakter und portabler Booster Booster compacte et portable pour la charge avec azote, avec actionnement pneumatique Booster compacto y portátil para la carga con nitrógeno con accionamiento neumático Booster compacto e portátil para carregar com nitrogênio com acionamento pneumático	2	Attacco per bombola Connection for bottle Ansatz für die Flasche Décapage pour bombonne Adaptador para bombona Ataque a Bottle	3*	Riduttore di pressione Pressure reducer Druckminderer Réducteur de pression Reductor de presión Redutor de pressão		
4	Tubo collegamento bombola con valvola di scarico Connecting hose from the bottle to the valve discharging Flaschen-Verbindungsschlauch mit Auslassventil Tube pour la connexion bombonne avec valve de décharge Tubo de conexión a bombona con válvula de descarga Tubo de ligação Frasco com a válvula de descarga	5	Ingresso aria Air inlet Luft Eingang Entrée de l'air Entrada de aire Entrada de ar	6*	Dispositivo di caricamento DMA Charging device DMA Lade-Vorrichtung DMA Dispositif de charge DMA Dispositivo de carga DMA Dispositivo de carregamento de DMA	7	Valvola sicurezza e ingresso aria Safety valve and air inlet Sicherheitsventil und Lufteingang Valve de sécurité et entrée de l'air Válvula de seguridad y entrada de aire Válvula de segurança e entrada de ar

IT Caratteristiche - Vantaggi

- Compatto, leggero e portabile
- Massimo utilizzo del volume bombola N2
- Installazione diretta su bombola N2
- Valvola di sicurezza output N2 max 220 bar

La fornitura comprende: Unità booster completa di valvola di sicurezza, supporto per bombola, 1 mt di tubo per collegamento a bombola o riduttore di pressione + attacco per bombola.

EN Features - Advantages

- Compact, light and portable
- Max use of the nitrogen bottle N2
- Direct installation on the N2 bottle
- Safety N2 output valve max 220 bar

The supply includes: Booster unit provided with safety valve, bottle support, 1 mt hose for connecting the bottle or pressure reducer + bottle connection.

DE Eigenschaften - Vorteile

- Kompakt, leicht und portabel
- Maximaler Nutzung der Stickstoffflasche N2
- Direkte Installation an Stickstoffflasche N2
- Sicherheitsventil output N2 , max. 220 bar.

Die Lieferung beinhaltet: Booster-Gerät versehen mit Sicherheitsventil, Träger für die Stickstoffflasche, 1 Meter Schlauch für den Anschluss zur Flasche oder zum Druckminderer + Ansatz für die Flasche.

FR Caractéristiques - Avantages

- Compacte, léger et portable
- Utilisation maximale de la bombonne d'azote N2
- Installation directe sur la bombonne d'azote N2
- Valve de sortie N2 sécurisé max 220 bar

La fourniture inclut: Unité booster équipé avec valve de sécurité, support pour bombonne, 1 mt de tube pour la connexion à la bombonne ou au réducteur de pression + Décapage bombonne.

ES Características - Ventajas

- Compacto, ligero y portátil
- Uso máximo de la bombona de nitrógeno N2
- Instalación directamente sobre la bombona de N2
- Válvula de seguridad, output N2 max 220 bar

El suministro incluye: Unidad Booster equipado con válvula de seguridad, soporte para la bombona de nitrógeno, tubo de 1 mt para la conexión a la bombona o al reductor de presión + Adaptador a Bombona.

PT Características - Benefícios

- Compacto, leve e portátil
- Máxima utilização do cilindro de nitrogênio N2
- Instalação directamente sobre o cilindro de N2
- Válvula de segurança, saída máxima de 220 bar N2

O fornecimento inclui: Unidade Booster equipado com válvula de segurança, o suporte para o cilindro de nitrogênio, 1 mt tubo para ligação ao cilindro de azoto ou de reductor de pressão + Ataque a Bottle.

AIR 1 - 10 bar 15 - 145 psi	220 bar 3190 psi	30 bar 435 psi	280 NL / min *	0 - 45 °C 32 - 113 °F	230 x 350 x 230 mm 9 x 13 x 9 inch	10,8 Kg 23.8 lbs

* Il rendimento volumetrico varia in funzione di Pair e PN₂ - The volumetric efficiency varies according to Pair and PN₂ - Der Volumen-Liefergrad ändert sich in Abhängigkeit vom Pair und PN₂
 Le rendement volumétrique varie en fonction de Pair et PN₂ - El rendimiento volumétrico varia en función de PN₂ - O rendimento volumétrico varia em função da Pair e PN₂

ACCESSORIES



IT Trolley completo di AirBooster e dispositivo 39DMB.

DE Trolley mit AirBooster und Füll- und Kontrollarmatur 39DMB.

ES Maleta completa con AirBooster y dispositivo 39DMB.

EN Trolley with AirBooster and charging device 39DMB.

FR Chariot avec AirBooster et kit de chargement 39DMB.

PT Maleta completa com Booster e Kit de carregamento 39DMB.



AirBooster



p. 129



39DMB



p. 120

code	Box content	Country
39KNCU03A	39NCU03A + 39DMB	Italy - Portugal
39KNCU04A	39NCU04A + 39DMB	China - Korea
39KNCU05A	39NCU05A + 39DMB	Japan - Indonesia
39KNCU06A	39NCU06A + 39DMB	Germany
39KNCU07A	39NCU07A + 39DMB	France
39KNCU08A	39NCU08A + 39DMB	India
39KNCU09A	39NCU09A + 39DMB	Russia
39KNCU26A	39NCU26A + 39DMB	USA
39KNCU27A	39NCU27A + 39DMB	USA
39KNCU28A	39NCU28A + 39DMB	Spain
39KNCU35A	39NCU35A + 39DMB	Korea
39KNCU36A	39NCU36A + 39DMB	Germany
39KNCU37A	39NCU37A + 39DMB	India
39KNCU38A	39NCU38A + 39DMB	Japan
39KNCU39A	39NCU39A + 39DMB	Portugal
39KNCU40A	39NCU43A + 39DMB	UK

IT Caratteristiche

Trolley con struttura antiurto e valvola pressurizzata per lo spostamento aereo e la sicurezza dei dispositivi all'interno.

EN Features

Trolley with shock-resistant structure and pressure relief valve for transport in the aircraft and safe storage of the contents.

DE Eigenheiten

Trolley mit stoßfester Struktur und Überdruckventil für den Transport im Flugzeug und ein sicheres Verstauen des Inhalts.

FR Caractéristiques

Chariot avec structure résistante aux chocs et soupape de surpression pour le transport dans l'avion et le stockage sécurisé du contenu.

ES Características

Maleta con estructura a prueba de golpes y válvula presurizada para viajes aéreos y para la seguridad de los dispositivos en el interior.

PT Características

Maleta de ferramentas com estrutura reforçada e pressurizada para viagens aéreas garantindo a segurança dos equipamentos.

IT Stazione mobile per caricamento, controllo forza e manutenzione dei cilindri ad azoto.

EN Mobile service station for charging, force testing and maintenance of gas springs.

DE Mobile Servicestation zum Befüllen, zur Druckkontrolle und zur Wartung der Gasdruckfedern.

FR Station de service mobile pour le chargement, la mesure de force et la maintenance de ressorts à gaz.

ES Estación móvil para carga, control de fuerza y mantenimiento de cilindros de gas.

PT Estação de trabalho movel para carregamento, ajuste de força e manutenção dos cilindros.

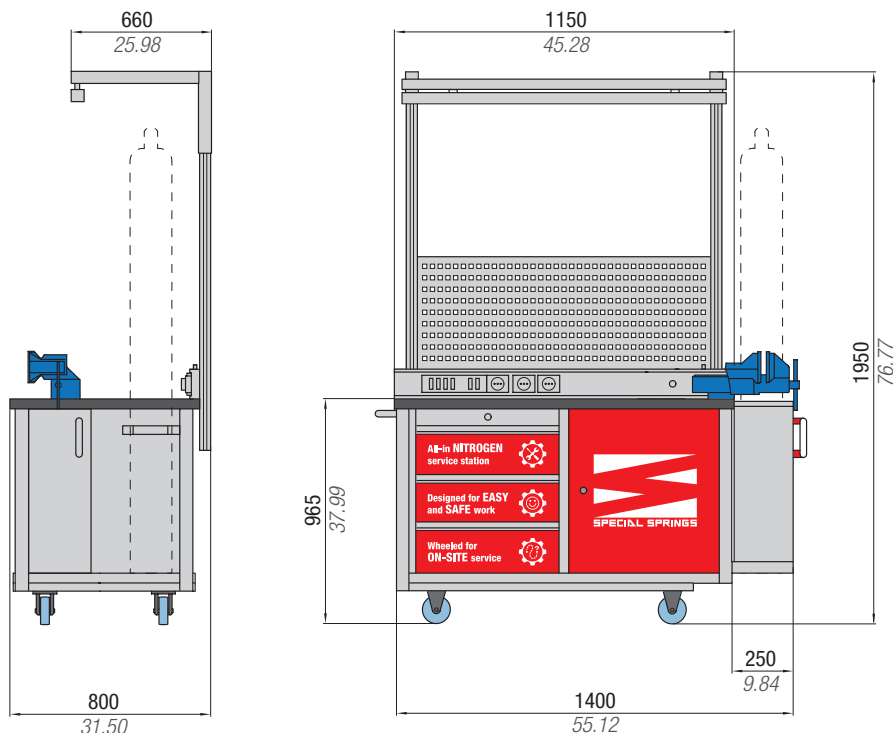

code	Country
58UT027A	Italy - Denmark Egypt - Russia Austria - Indonesia India - Greece Holland - Romania Finlandia Czech Republic Spain - France Slovenia - Portugal Turkey - Korea Germany
58UT031A	Japan - Usa
58UT032A	Belgium - France
58UT033A	United Kingdom
58UT034A	Brasil
58UT036A	China

 **225 kg / 496.04 lbs**

IT Vantaggi

- Unica postazione per strumenti e kit.
- Elevata mobilità.
- Maggiore sicurezza e comodità per ogni operazione.
- Predisposizione ancoraggio force tester.

FR Avantages

- Station tout-en-un pour tous outils et appareils.
- Grande mobilité.
- Plus de sécurité et de confort pour chaque opération.
- Préparé pour le montage du testeur de force.

IT Dati tecnici

- 3 cassetti (1 con vaschetta raccogli olio) + anta per riporre kit e tools.
- Piano di lavoro 1400 x 685 x 40 mm.
- Lampada a led con interruttore.
- Attacco aria compressa da 1/4".
- 3 prese elettriche.
- Connettore di alimentazione non incluso.
- Morsa parallela 130 mm.
- Protezione operatore da proiezione parti in fase di caricamento.

FR Données techniques

- 3 tiroirs (un avec bac de récupération d'huile) + compartiment fermé avec porte pour ranger kits et outils.
- Plan de travail 1400 x 685 x 40 mm.
- Lumière LED avec interrupteur.
- Alimentation en air comprimé 1/4".
- 3 prises de courant.
- La prise électrique n'est pas comprise.
- Étau parallèle 130 mm.
- Protection de l'opérateur contre la projection de pièces lors du chargement.

EN Advantages

- All-in-one station for all tools and devices.
- High mobility.
- More safety and comfort for each operation.
- Prepared for mounting of force tester.

ES Ventajas

- Estación todo en uno para herramientas y kits.
- Alta movilidad.
- Mayor seguridad y comodidad para cada operación.
- Preparada para el montaje de tester de fuerza.

EN Technical Data

- 3 drawers (one with oil drain pan) + compartment closed with door for storing kits and tools.
- Worktop 1400 x 685 x 40 mm.
- LED light with switch.
- Compressed air supply 1/4".
- 3 power sockets.
- The electrical plug is not included.
- Parallel vice 130 mm.
- Operator's protection against projection of parts during charging.

ES Datos técnicos

- 3 cajones (1 con bandeja de recogida de aceite) + puerta para guardar kit y herramientas.
- Encimera 1400 x 685 x 40 mm.
- Lámpara LED con interruptor.
- Conexión de aire comprimido de 1/4".
- 3 enchufes eléctricos.
- El enchufe eléctrico no está incluido.
- Tornillo de banco 130 mm.
- Protección del operador contra la proyección de piezas durante la carga.

DE Vorteile

- All-in-one Servicestation für Werkzeuge und Reparatursätze.
- Hohe Mobilität.
- Mehr Sicherheit und Komfort bei jedem Arbeitsschritt.
- Aufnahme zur Befestigung des Kraftmessgeräts.

PT Benefícios

- Todas as ferramentas e kit de carregamento em um só lugar.
- Total mobilidade.
- Maior segurança e comodidade.
- Já preparada para o Dinamometro.

DE Technische Daten

- 3 Schubladen (davon eine mit Ölauffangwanne) + mit Tür verschlossenes Fach zur Aufbewahrung von Reparatursätzen und Werkzeugen.
- Arbeitsplatte 1400 x 685 x 40 mm.
- LED-Leuchte mit Schalter.
- 1/4" Druckluftanschluss.
- 3 Steckdosen.
- Der Stromstecker ist nicht enthalten.
- Parallelschraubstock 130 mm.
- Schutz des Bedieners gegen das Herausspringen von Teilen beim Befüllen.

PT Dados técnicos

- 3 Gavetas (1 com espaços demarcados para os kits de manutenção) as outras para armazenar instrumentos e ferramentas.
- Mesa de trabalho de 1400 x 685 x 40mm.
- Lampada de LED com interruptor.
- Saída para ar comprimido 1/4".
- 3 tomadas.
- A ficha eléctrica não está incluída.
- Morsa paralela de 130mm.
- Proteção para o operador enquanto carrega os cilindros.

ACCESSORIES - DIGITAL FORCE TESTER



code 39FT02000

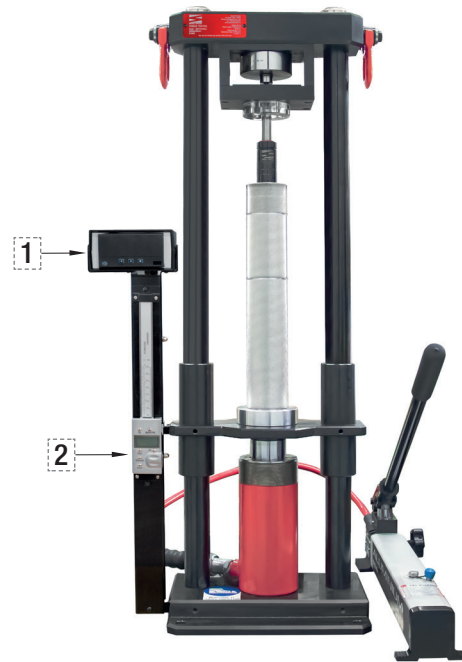

code 39FT00250B

code 39FT00500B

	Measuring range	0 ÷ 2000 daN <i>0 ÷ 4496 lb</i>	0 ÷ 250 daN <i>0 ÷ 562 lb</i>	0 ÷ 500 daN <i>0 ÷ 1124 lb</i>
	Recommended for FO	0 ÷ 1500 daN <i>0 ÷ 3372 lb</i>	0 ÷ 250 daN <i>0 ÷ 562 lb</i>	250 ÷ 500 daN <i>562 ÷ 1124 lb</i>
	Max. length	430 mm <i>16.93 inch</i>	430 mm <i>16.93 inch</i>	430 mm <i>16.93 inch</i>
	Max. diameter	75 mm <i>2.95 inch</i>	45 mm <i>1.77 inch</i>	45 mm <i>1.77 inch</i>
	Accuracy according EN ISO 7500-1	-	CLASS 1 (± 1%)	CLASS 1 (± 1%)
	Power supply	Battery (included)	100 - 240 VAC 50-60 Hz	100 - 240 VAC 50-60 Hz
	L x P x H	255 x 310 x 1300 mm <i>10.04 x 12.20 x 51.18 inch</i>	450 x 250 x 947 mm <i>17.72 x 9.84 x 37.28 inch</i>	450 x 250 x 947 mm <i>17.72 x 9.84 x 37.28 inch</i>
	Weight	22 Kg <i>48.50 lb</i>	83,5 Kg <i>184.09 lb</i>	83,5 Kg <i>184.09 lb</i>

code 59VCATM03







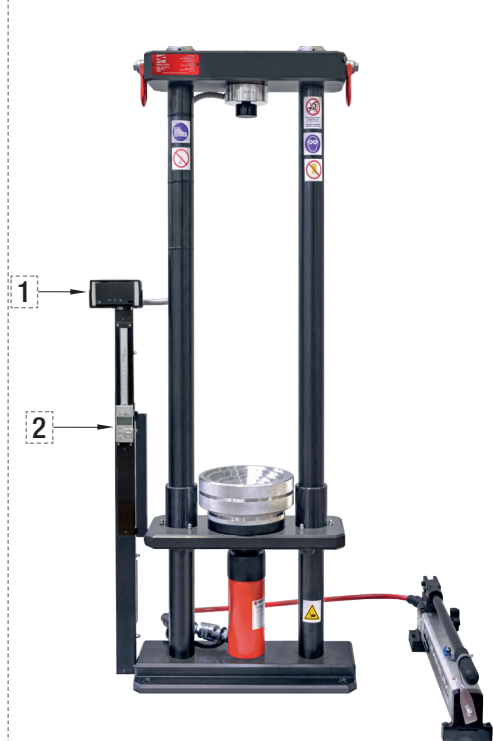
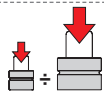

DIGITAL DISPLAY

code 59RE150

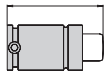
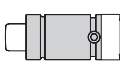

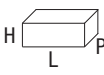
DIGITAL LINEAR SCALE

			
		code 39FT07500B	code 39FT20000
	Measuring range	0 ÷ 7500 daN 0 ÷ 16861 lb	0 ÷ 20000 daN 0 ÷ 44962 lb
	Recommended for FO	500 ÷ 7500 daN 1124 ÷ 16861 lb	7500 ÷ 20000 daN 16861 ÷ 44962 lb
	Max. length	400 mm 15.75 inch	760 mm 29.92 inch
	Max. diameter	120 mm 4.72 inch	195 mm 47.68 inch
	Accuracy according EN ISO 7500-1	CLASS 1 (± 1%)	CLASS 1 (± 1%)
	Power supply	100 - 240 VAC 50-60 Hz	100 - 240 VAC 50-60 Hz
	L x P x H	450 x 260 x 1350 mm 17.72 x 10.24 x 53.15 inch	577x250x1317 mm 22.72 x 9.84 x 51.85 inch
	Weight	88,5 Kg 195.11lb	197 Kg 434 lb

code 59VCATM03



DIGITAL DISPLAY

code 59RE150



DIGITAL LINEAR SCALE

NITRO STRIP



IT Carichi forti - estrattore a gas con forza di estrazione regolabile. Montaggio diretto su portapunzoni standard per punzoni ball-lock o con testa ISO 8020.

EN Heavy duty - Nitrogen gas stripper with adjustable force. Direct mounting on standard retainers for Ball-Lock or ISO 8020 punches.

DE Schwere Belastung - Gasdruck-Abstreifer mit einstellbarer Kraft. Direktmontage auf Standard-Stempelhalteplatten für Stempel mit Ball-Lock-System oder nach ISO 8020.

FR Charge lourde - Unité de dévêtissage à gaz avec force réglable. Montage direct sur les plaques porte-poinçon standard pour poinçons avec système Ball-Lock ou selon ISO 8020.

ES Carga pesada - Extractor de punzones de nitrógeno con fuerza ajustable. Montaje directo en porta punzones estándares para punzones Ball-Lock o según ISO 8020.

PT Carga pesada - Perfuradores de nitrogênio com força ajustável. Montagem directa em porta punções padrão para punções Ball-Lock ou segundo ISO 8020.

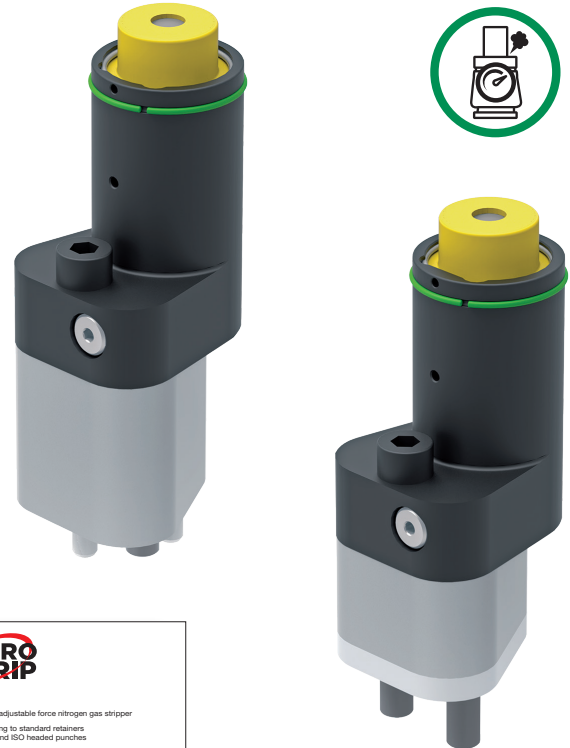

IT Richiedere o scaricare dal sito www.specialsprings.com il catalogo.

EN Ask for or download the catalog from our web site www.specialsprings.com.

DE Den Katalog von unsere Internetseite www.specialsprings.com herunterladen oder anfordern

FR Demandez ou téléchargez notre catalogue à partir de notre site web www.specialsprings.com.

ES Solicitar o descargar de la web www.specialsprings.com el catálogo.

PT Requerer ou descarregar no site www.specialsprings.com o catálogo.



IT Caratteristiche

- Montaggio diretto su portapunzoni standard
- Testina estrattore e premilamiera lunga o corta in bronzo guidata, rimovibile e sagomabile
- Testina anti-rotazione con 8 mm di corsa
- 4 codici colore standard indicativi del carico/forza
- 8 modelli per punzoni da 10 a 40 mm di diametro
- Forza a contatto fino a 1880 daN / 4200 lbf
- Forza di estrazione fino a 3200 daN / 7200 lbf
- Forza di estrazione regolabili
- Collegabile con altre unità NITRO STRIP per massima flessibilità
- Sicurezza OPAS inclusa come standard
- Dimensioni compatte

EN Features

- Direct mounting on standard retainers
- Bronze stripping head that is guided, demountable and machinable. Available short or long
- Anti-rotation head with 8 mm stroke
- 4 standard color codes for different forces/loads
- 8 models with punch diameter from 10 to 40 mm
- Contact force as high as 1880 daN / 4200 lbf
- Stripping force as high as 3200 daN / 7200 lbf
- Adjustable stripping force
- Connectable with other NITRO STRIP units for maximum flexibility
- OPAS built-in as standard
- Compact design

DE Merkmale

- Direktmontage auf Standard-Stempelhalteplatten
- Abstreiferkopf aus Bronze, geführt, abnehm- und bearbeitbar. Verfügbar kurz oder lang
- Abstreiferkopf verdrehgesichert, mit einem Hub von 8 mm
- 4 Standard-Farbcodes für verschiedene Kräfte/ Belastungen
- 8 Modelle mit Stempeldurchmesser von 10 bis 40 mm
- Kontaktkraft bis zu 1880 daN / 4200 lbf
- Abstreiferkraft bis zu 3200 daN / 7200 lbf
- Abstreiferkraft einstellbar
- Anschließbar mit anderen NITRO STRIP Einheiten für maximale Flexibilität
- OPAS standardmäßig eingebaut
- Kompaktes Design

FR Caractéristiques

- Montage direct sur les plaques porte-poinçon standard
- Tête de dévêtisseur de bronze, guidée, démontable et qui peut être usinée. Disponible courte ou longue
- Tête de dévêtisseur résistant à la torsion, avec une course de 8 mm
- 4 codes couleur standard avec différentes forces/charges
- 8 modèles avec diamètres de poinçon de 10 à 40 mm
- Force de contact jusqu'à 1880 daN / 4200 lbf
- Force de dévêtisseur jusqu'à 3200 daN / 7200 lbf
- Force de dévêtisseur ajustable
- Possibilité de relier avec autres unités NITRO STRIP pour une flexibilité maximale
- OPAS installée de série - Design compact

ES Características

- Montaje directo en porta punzones estándares
- Pisador bronce guiado, desmontable y mecanizable. Disponible con 2 longitudes.
- Con antigiro y carrera de 8 mm
- 4 códigos de colores estándares según la fuerza/carga requerida
- 8 modelos para diámetros de punzón de 10 a 40 mm
- Fuerza de contacto hasta 1880 daN / 4200 lbf
- Fuerza de extracción hasta 3200 daN / 7200 lbf
- Fuerza de extracción ajustable
- Conectable a otras unidades NITRO STRIP para una máxima flexibilidad
- OPAS incluida como estandar
- Diseño compacto

PT Características

- Montagem directa em porta punções padrão
- Cabeça do destacador em bronze, guiada, removível e de fácil usinagem. Disponível curta ou longa
- Cabeça anti-rotação com curso de 8 mm
- 4 códigos de cores padrão para diferentes forças/cargas
- 8 modelos com diâmetro da punção de 10 a 40 mm
- Força de contato até 1880 daN / 4200 lbf
- Força de extração até 3200 daN / 7200 lbf
- Força de extração pode ser ajustada
- Possibilidade de interligação com outras unidades NITRO STRIP para o máximo de flexibilidade
- OPAS como padrão
- Design compacto

IT Carichi forti - estrattore a gas con forza di estrazione regolabile. Montaggio diretto con punzoni ISO 8020.

EN Heavy duty - Nitrogen gas stripper with adjustable force. Direct mounting with ISO 8020 punches.

DE Schwere Belastung - Gasdruck-Abstreifer mit einstellbarer Kraft. Direktmontage mit Stanzen ISO 8020.

FR Charge lourde - Unité de dévêtissage à gaz avec force réglable. Montage direct avec poinçons ISO 8020.

ES Carga pesada - Extractor de punzones de nitrógeno con fuerza ajustable. Montaje directo con punzones ISO 8020.

PT Carga pesada - Perfuradores de nitrogénio com força ajustável. Montagem direta com punções ISO 8020.

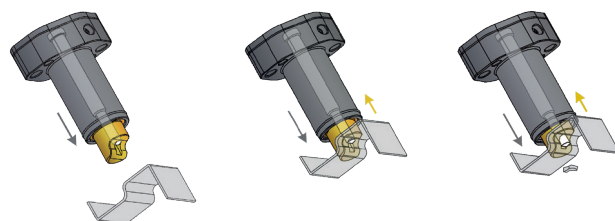
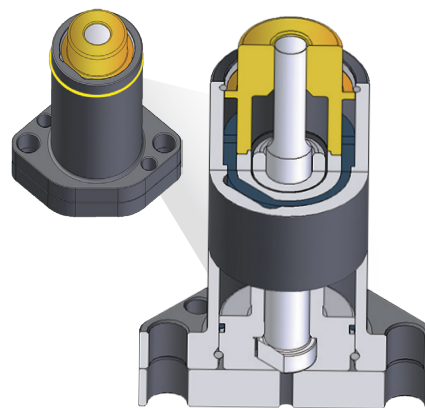

IT Richiedere o scaricare dal sito www.specialsprings.com il catalogo.

EN Ask for or download the catalog from our web site www.specialsprings.com.

DE Den Katalog von unsere Internetseite www.specialsprings.com herunterladen oder anfordern

FR Demandez ou téléchargez notre catalogue à partir de notre site web www.specialsprings.com.

ES Solicitar o descargar de la web www.specialsprings.com el catálogo.

PT Requerer ou descarregar no site www.specialsprings.com o catálogo.



IT Caratteristiche

- Testa premilamiera estraibile e sagomabile
- Facile posizionamento e fissaggio
- Elevata forza di estrazione
- Dimensioni compatte
- Adatto per punzoni ISO 8020
- Non è richiesto l'uso di altro portapunzione
- Ideale per uso combinato con unità cam

EN Features

- Stripper head removable and mouldable
- Easy positioning
- High and adjustable holding and stripping force
- Compact dimensions
- Suitable for ISO 8020 shoulder style punch
- Doesn't require the use of standard retainer
- Ideal for combined use with cam unit

DE Merkmale

- Niederhalterkopf herausnehmbar und mit bearbeitbarer Kontur
- Einfache Positionierung
- Hohe und einstellbare Niederhalter- und Abstreiferkraft
- Kompakte Größe
- Geeignet für Schneidstempel ISO 8020
- Andere Stempelhalteplatten sind nicht erforderlich
- Ideal für den Einsatz in Kombination mit Schiebern

FR Caractéristiques

- Tête de bronze que peut être modelée et extraite
- Positionnement facile
- Force élevée de extraction
- Dimensions compactes
- Indiqué pour poinçons ISO 8020
- Il ne demande pas l'emploi de autre poinçon
- Idéal à utiliser avec l'unité CAM

ES Características

- Pisador desmontable y mecanizable
- Fácil posicionamiento y amarre
- Fuerza de extracción muy elevada y ajustable
- Dimensiones compactas
- Apropiado para punzón con cabeza ISO 8020
- No requiere uso de porta punzón
- Ideal para utilizar con carro de punzonado

PT Características

- Cabeça de corte fácil remoção e maquinavel
- Fácil posicionamento
- Fixação alta e ajustável e força de corte
- Dimensões compactas
- Adequado para punção o ISO 8020 respigado
- Não necessita do uso de um retentor normalizado
- Ideal para uso combinado com uma unidade CAM





EUROPE

Headquarters

Special Springs S.r.l.
Via Nardi, 124/A
36060 Romano d'Ezzelino (VI) - ITALY
tel. +39 0424 539181
email: info@specialsprings.com
www.specialsprings.com

French Subsidiary

Special Springs France
Impasse de la Birbadière
49650 Allonnes - FRANCE
Ph. +33 (0)6 37 62 76 62
email: contact@specialsprings.fr
www.specialsprings.com

AMERICA

North American Subsidiary

Special Springs LLC
7707 Ronda Drive, Canton
Michigan 48187 - USA
Ph. +1 734.892.2324
email: info@specialspringsna.com
www.specialspringsna.com

South American Subsidiary

Special Springs do Brasil
Avenida dom Pedro I, 2156 - Vila Pires
09130-012 Santo André / SP - BRASIL
Ph. +55 11 2324 3545
email: comercial@specialsprings.com.br
www.specialsprings.com.br

ASIA

Indian Subsidiary

Global Special Springs pvt. Ltd.
Survay no. 69/2 - Chandarda, Tal. Kadi
Dist. Mehesana (Ahmedabad - Melakhwa
Gujarat, 382705 - INDIA
Ph. +91 2764 273065
email: info@globalspecialsprings.com
www.specialsprings.com

Catalog code

9800C73400024

