

Installation and Operating Manual Pneumatic Transporter

ESSEMEC
INNOVATIVE DIES SOLUTIONS

newstark
INNOVATIVE METAL SOLUTIONS

Installation and Operating Instruction Manual Pneumatic Transporters

0804.0040/0804.0070

This manual is designed to help you to get to know the transporter quickly and to use it correctly.

Newstark high quality transporters are the result of years of production and development, so they are easy to use, safe and very reliable.

But you must still read the Installation and Operating Manual, because it contains important hints and tips for using transporters correctly and safely.

By following it closely you will avoid risks, reduce repair costs & downtime and you will obtain maximum reliability and service life from your transporter.

It is mandatory for anyone working on, with or near pneumatic transporters to read and understand the Installation and Operating Manual. This also applies to anyone who works with or on the Transporter only occasionally, such as maintenance and cleaning personnel.

This Installation and Operating Manual must be readily available at the workplace.

Index of contents

Foreword	2
Safety regulations	2
Function and use	4
Assembly	5
Applications	7
0804.0040	6
0804.0070	8

Use

Newstark transporters are intended solely for use as a vibrating channel for transporting parts (see also Load Capacity).

No other use or development of this use is authorised and the manufacturer cannot be held responsible for any damage resulting from incorrect operation.

In such a case the user alone is entirely responsible for any risks arising.

The transporter is a unit for incorporating in a complete installation by the user in accordance with best practice in the machine tool industry.

Correct use of the equipment includes following the instructions for use in this Manual and in particular observing the authorised load limits detailed in the technical specifications.

The basics

Newstark transporters are state of the art technology. Although they are designed to comply with current health and safety laws, they are potentially dangerous to users and third parties and can cause damage to the transporter and to other machinery.

IMPORTANT

- only use a transporter which is in perfect condition;
- transporters must be used in compliance with accident prevention legislation;
- transporters must be used in compliance with safety regulations;
- when using transporters, always be aware of the potential dangers.

Any faults, and especially those affecting safety, must be dealt with immediately by trained staff. The transporter must be taken out of use until the fault has been corrected.

Health and Safety

Safety Rules for the operator

The employer shall ensure that all work, repairs and maintenance by his staff are carried out strictly in accordance with this Installation and Operating Manual. He is responsible for providing all safety-relevant equipment, facilities and documentation.

Never work in a way that:

- could cause injury or death to the user or third parties;
- could damage the transporter or other equipment;
- endangers the safe operation of the transporter.

Installation and Operating Instruction Manual Pneumatic Transporters

0804.0040/0804.0070

Duty of care and maintenance

Inspect transporters for visible external damage or faults at least once per shift. Report any change in the equipment or its operating performance immediately to the appropriate authority or the person responsible.

If the transporter malfunctions, stop it immediately. Faults must be repaired only by trained personnel. Pneumatic transporters must be kept and operated in perfect condition.

It is essential therefore that all references in the manual to settings & maintenance, inspection & service schedules and instructions for the replacement of parts or assemblies are adhered to absolutely.

Any faults discovered must be corrected immediately. Spare parts must meet the NEWSTARK technical specifications so we recommend the use of genuine original spare parts and repair kits.

The manufacturer cannot accept any responsibility for customer modifications to transporters.

Safety and danger zones

Danger of crushing and cutting:

there is relative movement between the base and the slide frame of the transporter, so there is a risk of crushing and cutting. We recommend the use of work gloves of a suitable grade to reduce the danger of cuts. Ideally the danger areas should be protected by a guard or an infrared beam cut-out.

Pneumatics:

only suitably trained personnel should work on pneumatic equipment. If the air supply to a Transporter fails it must be switched off immediately. Even the most modern design and technology cannot eliminate all the risks inherent in working with pneumatic tools such as hose connections loosening or bursting. Machinery must be fail-safe in case of power failure: all machines must have a positive cut-out and there must be no risk or danger to any operator or user.

Safety Regulations:

it is essential to observe the following legal regulations:

- health and Safety regulations;
- company safety regulations;
- environmental legislation.

Supplementary safety rules

When using oils, greases and other chemical substances it is essential to follow all the product safety codes.

Transporters must not be operated in potentially explosive environments.

Only trained personnel may use the equipment. All responsibilities for operation, maintenance and repair must be clearly laid down.

Staff must not wear their hair long or wear loose clothing or jewellery, including rings, as there is a danger of being caught up or dragged into the machinery.

No person who is under the influence of alcohol or drugs or whose reactions are impaired by medication may work on or near Transporters.

If any other risks or dangers not described in the Installation and Operating Manual become apparent, it is the duty of the employer/operator of the Transporter to inform NEWSTARK in writing immediately.

Function and use of transporters

This pneumatic Transporter is a unique, patented design. It was designed to provide an effective and affordable solution to the problems of conveying parts and disposing of waste. This beltless conveyor system transports stampings and waste from the tool area by means of vibration alone.

A specially designed conveyor channel which is screwed to the body of the Transporter vibrates rhythmically, moving forwards slowly and backwards fast. As it moves slowly forwards it carries the item forwards with it, but when it jerks back suddenly, the mass and inertia of the item cause it to stay where it is. Transporters are used mainly with press and punching equipment.

The conveyor channels can be manufactured from various materials. It is important that the material chosen for the conveyor channel should be as light but stiff as possible. The conveyor channel can be matched to suit the installation and transport requirements. It is important that the edges of the conveyor channel should be sufficiently high to prevent items falling off. Conveyor channels must be supported by a linear support. Using a linear support effectively reduces unintentional vibration of the conveyor channel, and results in improved performance and service life.

When mounted, the conveyor channel must move freely on the linear support, as unnecessary friction will reduce performance.

Installation and Operating Instruction Manual Pneumatic Transporters 0804.0040/0804.0070

Applications

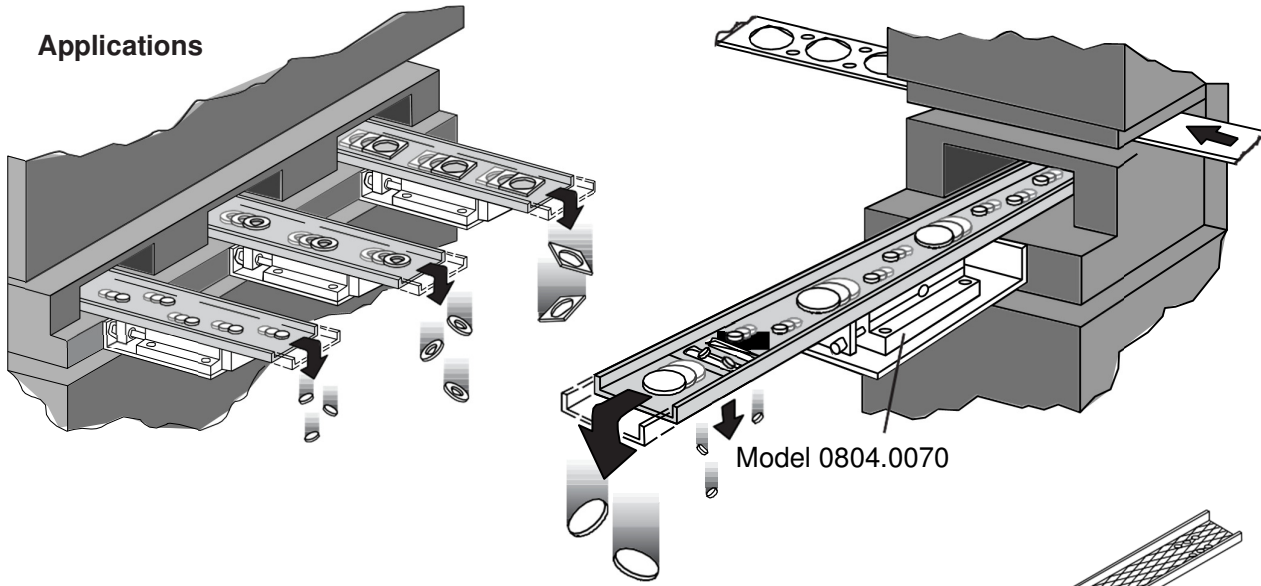

Model 0804.0070



Design the conveyor channel to suit your application

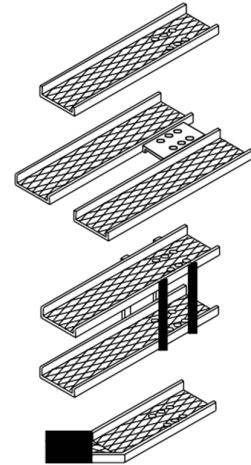

Third stage Blank
Second Stage Punch
First Stage Pierce

Model 0804.0070

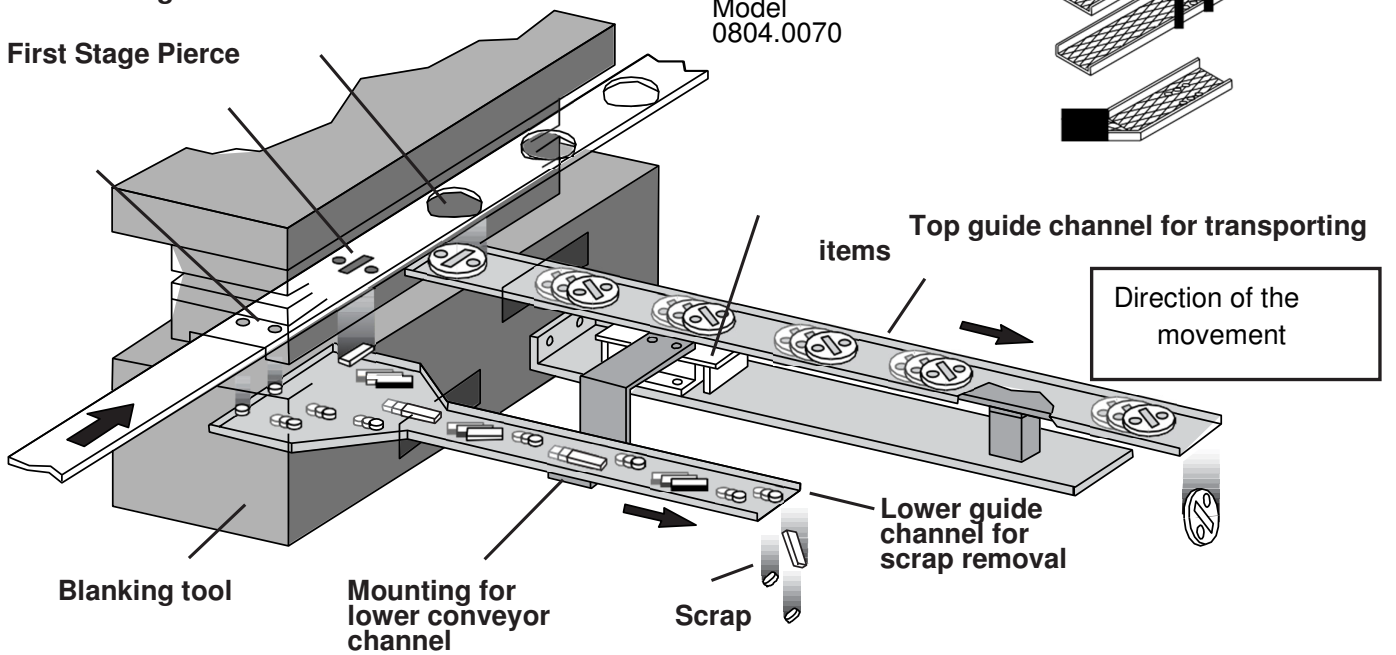

Assembly

1. Rigidly mount the Transporter to a solid surface using these recommended screw sizes:

Model	Quantity	Metric Size	Inch
0804.0040	2	M10	3/8
0804.0070	6	M8	5/16

Installation and Operating Instruction Manual Pneumatic Transporters 0804.0040/0804.0070

2. The airline uses an oil mist combination filter, regulator, lubricator and pressure gauge. Set the pressure to 4-5 bar.



Do not exceed 5.5 bar as excess pressure will damage the Transporter.

Recommended airline connection to eliminate moisture and particles

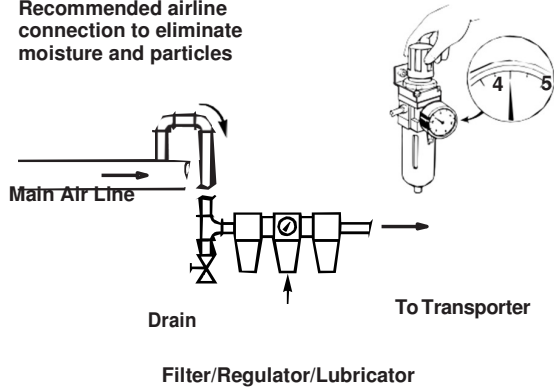

- Fill the lubricator with a good grade of hydraulic oil, such as Shell Tellus 32 or equivalent. Set for one (1) drop per minute.
- Use flexible poly-flow air lines on transporters. On model 0804.0040 and 0804.0070, use 3/8" tubing for 1/4" NPT connection.

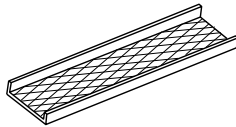

5. The conveyor channel should be designed as a standard "U" profile guide channel to handle your specific application or tool. Any material can be used but NEWSTARK recommends aluminium or light gauge perforated panel material to reduce guide channel weight. Maximum guide channel weight should not exceed:

Model	max. weight channel only and items		max. weight incl. channel	
	kg	lbs.	kg	lbs.
0804.0040	5,4	12	40	80
0804.0070	11,3	25	70	140

6. Fasten guide channel to the transporter using all the mounting holes. Be sure to use washers or spacers between the Transporter and the guide channel and using the following mounting screws:

Model	Quantity	Screw size	Depth
0804.0040	6	M8	9 mm
0804.0070	6	M8	8 mm

7. Conveyor guide channel must be supported at both ends to minimize deflection and unintended vibration. Roller slides or low friction material can be used for the guide channel to slide on.

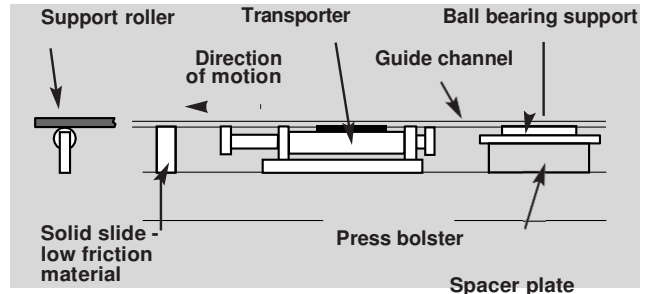

- Speed adjustment is preset at the factory with the correct frequency for a light weight guide channel. The speed can be regulated by turning the screw or knob clockwise to decrease the movement on the model 0804.0040 to reduce the speed of the 0804.0070 turn the screw counterclockwise. Parts and scrap will be moved efficiently at less than maximum speed.
- The vibration frequency of the 0804.0040 can be regulated by releasing the air regulator rod 8099.0040.2200.001 then unscrewing the locking screw. Gently push for-wards to increase speed or backwards to decrease speed.
- Once a week, spray the piston rods with the same Tellus oil, as used for air lubrication.
- If there is a build-up of sticky oil on the conveyor guide channel or if the parts or scrap are very oily, this may inhibit efficient transport. In such cases reduce the coefficient of friction by dimpling the surface of the guide channel with a ballpeen hammer or use a different material like expanded metal or profiled, perforated metal for the guide channel.

Installation and Operating Instruction Manual Pneumatic Transporters 0804.0040

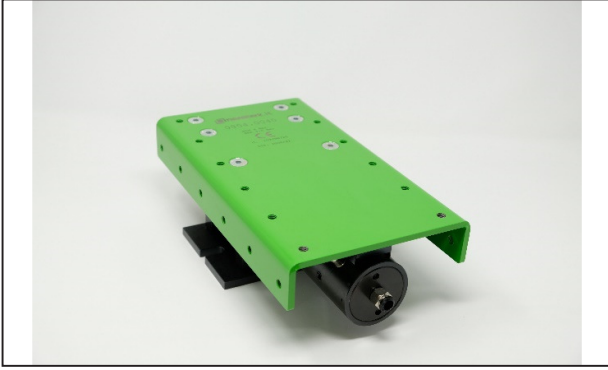

1. Remove the air regulator rod 8099.0040.2200.001 by loosening the locking screw 9007.05.010.129.1.4026 in the top of the slide frame and slide the rod out. If it is deformed, it must be replaced.
2. Remove the two (2) panhead screws which secure the stop washers 8006.0350.0250.065.001 to the slide frame. Remove lock nut 9014.12.014.006.1.7040 from the front end of the piston rod. Then remove the slide frame together with the guide columns.
3. Remove the top plate 8010.0803.0040 which holds the air regulator 8101.0140.0255.001 and felt covers 8051.1040. Check regulator O-ring 9023.0018.0045.070 for damage.
4. Remove the plug 8005.0530.215.001 from the piston rod and check plug O-ring 9023.0025.0110.070
5. Disconnect airline 8102.0040.1280.001.
6. Remove rear air inlet cap 8101.0500.0139.001). Check O-ring 8085.0020.0540.130.001 for damage.

7. Remove the 8 screws 9007.06.016.129.1.5933 from the bottom mounting plate and slide piston housing away from body.

8. Remove the valve disk 8104.0250.0070.001 by unscrewing the valve disc screw. Prevent the rod from rotating with a 3 mm hex wrench at the end of the valve rod.

It is now possible to take out the piston 8100.0490.1350.001.

9. To remove the valve rod 8104.0220.0070.001 / 8099.0080.0570.001 / 8006.0530.0170.080.001 / 8099.0080.1071.001 from the piston, hold the exposed valve seal gently in a vice. Remove the screw using a 3 mm hex wrench.

10. Replace the long valve spring 8085.0020.0540.130.001 and the short valve spring 8085.0020.0300.130.001.

Reassembly

Reassemble in reverse order, being careful not to bend the valve rod 8104.0220.0070.001 / 8099.0080.0570.001 / 8006.0530.0170.080.001 / 8099.0080.1071.001 and valve seals.

Factory Repair and Rebuild Service Return the Transporter carriage paid to our NEWSTARK Repair Centre.

After inspection, we will notify you of the parts and labour costs.

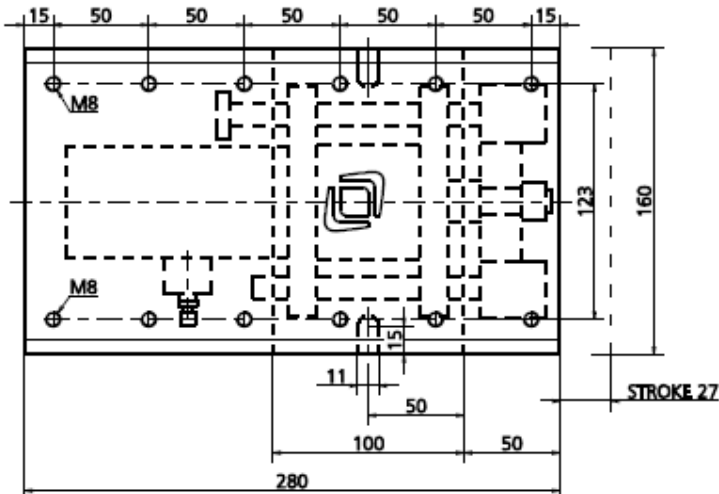
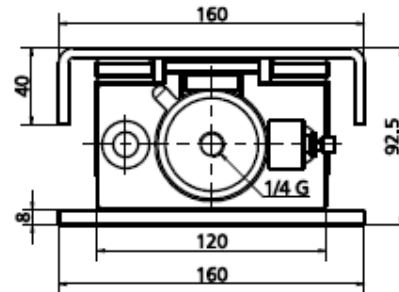
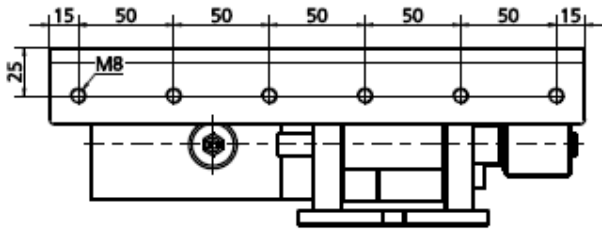

Installation and Operating Instruction Manual Pneumatic Transporters 0803.0040

Num.	Articolo	Descrizione	Q.tà	Num.	Articolo	Descrizione	Q.tà
1	8030.1600.1000.080.001	PIASTRINA 1	1	30	8103.0803.0040.001	REGOLATORE	1
2	8030.1200.0720.150.001	PIASTRINA 2	1	31	8103.0803.0040.002	REGOLATORE	1
3	8030.1200.0720.150.002	PIASTRINA 3	1	32	8101.0220.0030.001	TAPPO	1
4	8007.0803.0040	SLITTA	1	33	8104.0250.0070.001	ESAGONO	1
5	8010.0803.0040	COPERCHIO	1	34	8105.0803.0040.001	SILENZIATORE	4
6	8098.0618.0500.150.001	CILINDRO	1	35	8085.0010.0220.220.001	MOLLA A FILO	1
7	8098.0600.0300.066.001	CILINDRO	1	36	8085.0020.0300.130.001	MOLLA A FILO	1
8	8013.0980.0250.140.001	BOCCOLA	2	37	8085.0020.0540.130.001	MOLLA A FILO	1
9	8099.0120.1390.001	ASTA	1	38	9023.0053.0375.070	GUARNIZIONE O-RING	1
10	8099.0120.1530.001	ASTA	1	39	9023.0026.0238.070	GUARNIZIONE O-RING	2
11	8100.0490.1350.001	PISTONE	1	40	9023.0030.0350.070	GUARNIZIONE O-RING	1
12	8051.1040	CARTER	1	41	9023.0025.0110.070	GUARNIZIONE O-RING	1
13	8101.0500.0139.001	TAPPO	1	42	9023.0010.0030.070	GUARNIZIONE O-RING	1
14	8013.0300.0140.120.001	BOCCOLA	4	43	9023.0018.0045.070	GUARNIZIONE O-RING	1
15	8006.0350.0250.065.001	RONDELLA	1	44	9007.08.008.129.1.4026	GRANO M8x8	1
16	8006.0353.0120.055.001	RONDELLA	1	45	9007.06.016.129.1.4762	VITE M6x16	2
17	8005.0530.0530.215.001	PERNO	1	46	9007.05.010.129.1.4026	GRANO M5x10	1
18	8006.0420.0250.120.001	RONDELLA POLIURETANO	3	47	9014.12.014.006.1.7040	DADO M12	1
19	8006.0420.0180.120.001	RONDELLA POLIURETANO	2	48	9013.1324.25.1.7089	RONDELLA	2
20	8102.0040.1280.001	TUBO ARIA	1	49	9021.02.G018.004	ATTACCO ARIA 1/8 GAS A 90°	2
21	8099.0040.2200.001	ASTA	1	50	9007.05.012.088.1.9327	VITE M5x12	1
22	8013.0269.0200.082.001	BOCCOLA	1	51	9023.0015.0055.070	GUARNIZIONE O-RING	1
23	8013.0168.0250.082.001	BOCCOLA	1	52	9038.0300.0500.100.01	PARAOLIO V-RING	2
24	8104.0220.0070.001	ESAGONO	1	53	9007.05.010.129.1.5933	VITE M5x10	3
25	8099.0080.0570.001	ASTA	1	54	9007.06.016.129.1.5933	VITE M6X16	9
26	8006.0530.0170.080.001	RONDELLA POLIURETANO	2	55	9038.0080.0140.040.01	PARAOLIO V-RING	2
27	8099.0080.1071.001	ASTA	1	56	8072.0040	SCIVOLO	1
28	8101.0140.0255.001	TAPPO	1	57	9007.08.012.129.1.5933	VITE M8X12	6
29	8098.0250.0150.019.001	CILINDRO	1				

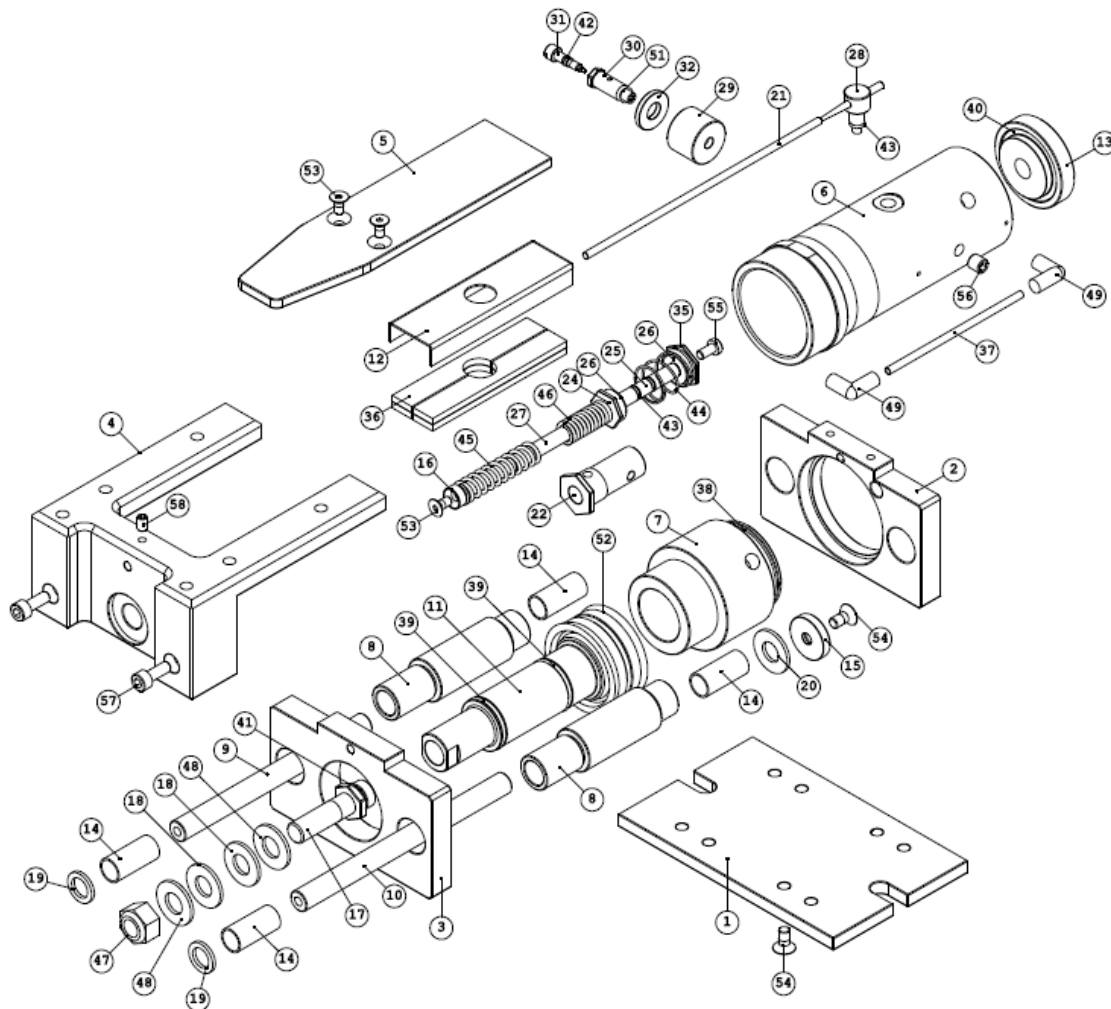

* Included in repair kit 8107.0803.0040.001

Installation and Operating Instruction Manual Pneumatic Transporters 0803.0070

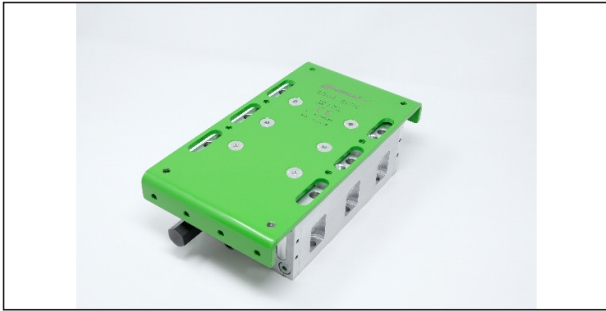

Disassembly

1. Remove the nut 8104.0350.0067.001 from the rear piston 8100.0490.0607.001 and push the piston inside the cylinder.
2. Remove the 8 holding screws 9007.08.016.088.1.9327 and slacken the 8 screws 9007.05.008.129.1.4026 They do not need to be removed.
3. Pull front and rear holders 8030.1400.0750.100.002 and 8030.1400.0750.100.001 away from body while holding the outer guide assemblies 8030.2080.0750.200.001 to prevent bearings from being lost. The front piston 8100.0420.0673.001 and shock absorber 9039.0140.0120.001 will come out with the front holder. The speed adjustment assembly will come out with the rear holder.
4. Now remove the front and rear retaining plates 8030.0970.0750.060.002 and 8030.0970.0750.060.001 by unscrewing the screws 9007.06.010.088.1.9327. The rear piston 8100.0490.0607.001 can now be removed from the body.
5. Unscrew the side locking screw 9007.06.008.129.1.4026 and remove the speed adjustment valve 8013.0717.0160.120.001.

6. Unscrew valve seals 8006.0530.0170.080.001 and pull out. Check all wipers, seals and O-rings for wear or damage. Check that the valve seals are smooth, and valve rod 8005.0695.0555.080.001 is straight.

Reassembly

When reassembling, take care with the following:

1. Install speed adjustment valve and align indent with the speed adjustment valve locking screw.
2. Don't forget to install the front and rear cylinder urethane washers 8005.0695.0555.080.001 / 8104.0250.0070.001 and 8104.0250.0070.001 on the front and rear cylinders.
3. Before tightening the holder screws, use the 9007.05.008.129.1.4026 screws to remove any play in the slide assembly.

Factory Repair and Rebuild Service

Return the Transporter carriage paid to our NEWSTARK Repair Centre.

After inspection, we will notify you of the parts and labour costs.

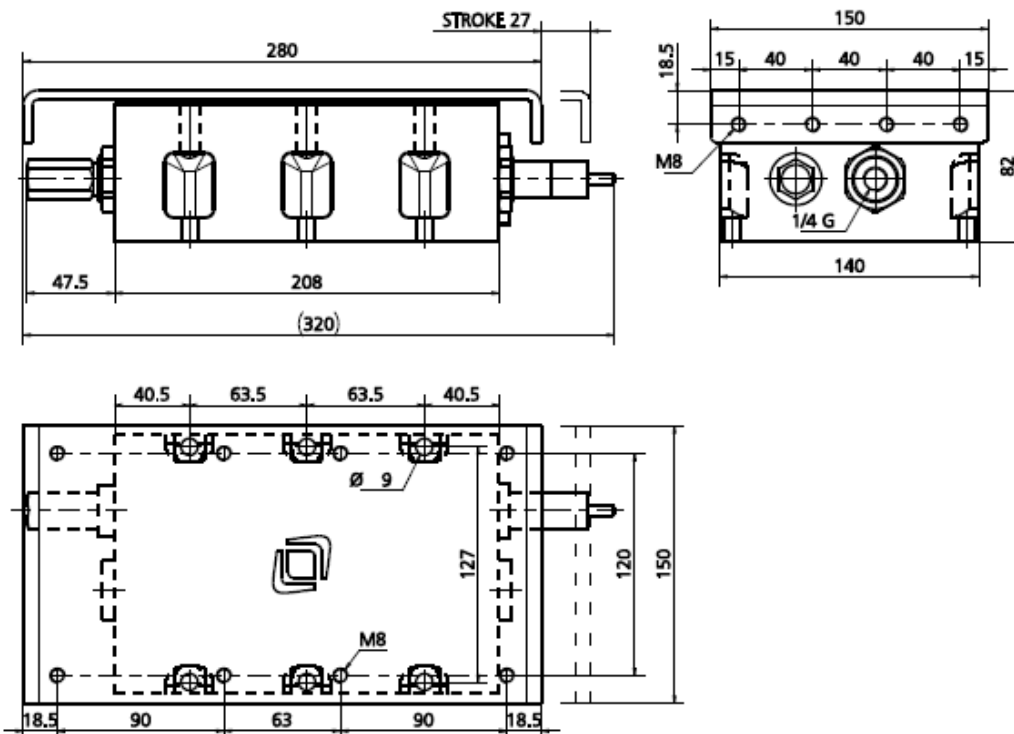

Installation and Operating Instruction Manual Pneumatic Transporters

0803.0070

Num.	Articolo	Descrizione	Q.tà	Num.	Articolo	Descrizione	Q.tà
1	8037.0070	CORPO	1	27	8104.0350.0067.001	ESAGONO	2
2	8030.2080.0750.200.002	PIASTRINA 1	2	28	8085.0010.0220.220.001	MOLLA A FILO	1
3	8030.1400.0750.100.001	PIASTRINA 2	1	29	8085.0020.0540.130.001	MOLLA A FILO	2
4	8030.1400.0750.100.002	PIASTRINA 3	1	30	9023.0018.0045.070	GUARNIZIONE O-RING	2
5	8030.0970.0750.060.001	PIASTRINA 4	1	31	9022.0050	SFERA Ø5	56
6	8030.0970.0750.060.002	PIASTRINA 5	1	32	9038.0420.0500.050.001	PARAOLIO V-RINV	1
7	8012.1875.0500.040.001	PIASTRINA DI SCORRIMENTO	2	33	9039.0140.0120.001	AMMORTIZZATORE	1
8	8012.1430.0500.040.001	PIASTRINA DI SCORRIMENTO	2	34	9004.2320.001	SEEGER	2
9	8030.1140.0570.005.001	PIASTRINA 6	2	35	9023.0025.0200.070	GUARNIZIONE O-RING	1
10	8006.0420.0530.300.001	RONDELLA POLIURETANO	2	36	9023.0024.0093.070	GUARNIZIONE O-RING	1
11	8005.0695.0555.080.001	PERNO	1	37	9023.0015.0090.070	GUARNIZIONE O-RING	1
12	8104.0250.0070.001	ESAGONO	2	38	9023.0024.0113.070	GUARNIZIONE O-RING	1
13	8006.0530.0170.080.001	RONDELLA POLIURETANO	2	39	9038.0420.0500.060.001	PARAOLIO V-RINV	1
14	8100.0420.0673.001	PISTONE	1	40	9007.06.010.129.1.5933	VITE M6X10	14
15	8100.0490.0607.001	PISTONE	1	41	9007.06.010.088.1.9327	VITE M6X10	12
16	8013.0330.0312.100.001	BOCCOLA	1	42	9007.08.016.088.1.9327	VITE M8X16	8
17	8013.0265.0312.150.001	BOCCOLA	1	43	9007.08.008.129.1.4026	GRANO M8x8	1
18	8101.0248.0100.001	TAPPO	1	44	9007.06.008.129.1.4026	GRANO M6x8	1
19	8013.0300.0240.140.001	BOCCOLA	1	45	9007.05.008.129.1.4026	GRANO M5x8	8
20	8099.0060.1660.001	ASTA	1	46	9014.06.005.008.1.4032	DADO M6	1
21	8103.0803.0070.001	REGOLATORE	1	47	9013.1528.25.1.7089	RONDELLA	1
22	8013.0483.0250.160.001	BOCCOLA	1	48	8030.0490.0300.060.001	PIASTRINA	1
23	8013.0302.0120.100.001	BOCCOLA	1	49	9007.06.016.129.1.4762	VITE M6X16	2
24	8013.0717.0160.120.001	BOCCOLA	1	50	8072.0070	SCIVOLO	1
25	8104.0220.0450.001	ESAGONO	1	51	9007.08.012.129.1.5933	VITE M8X12	6
26	8106.0160.0160.001	INSERTO FILETTATO	6				

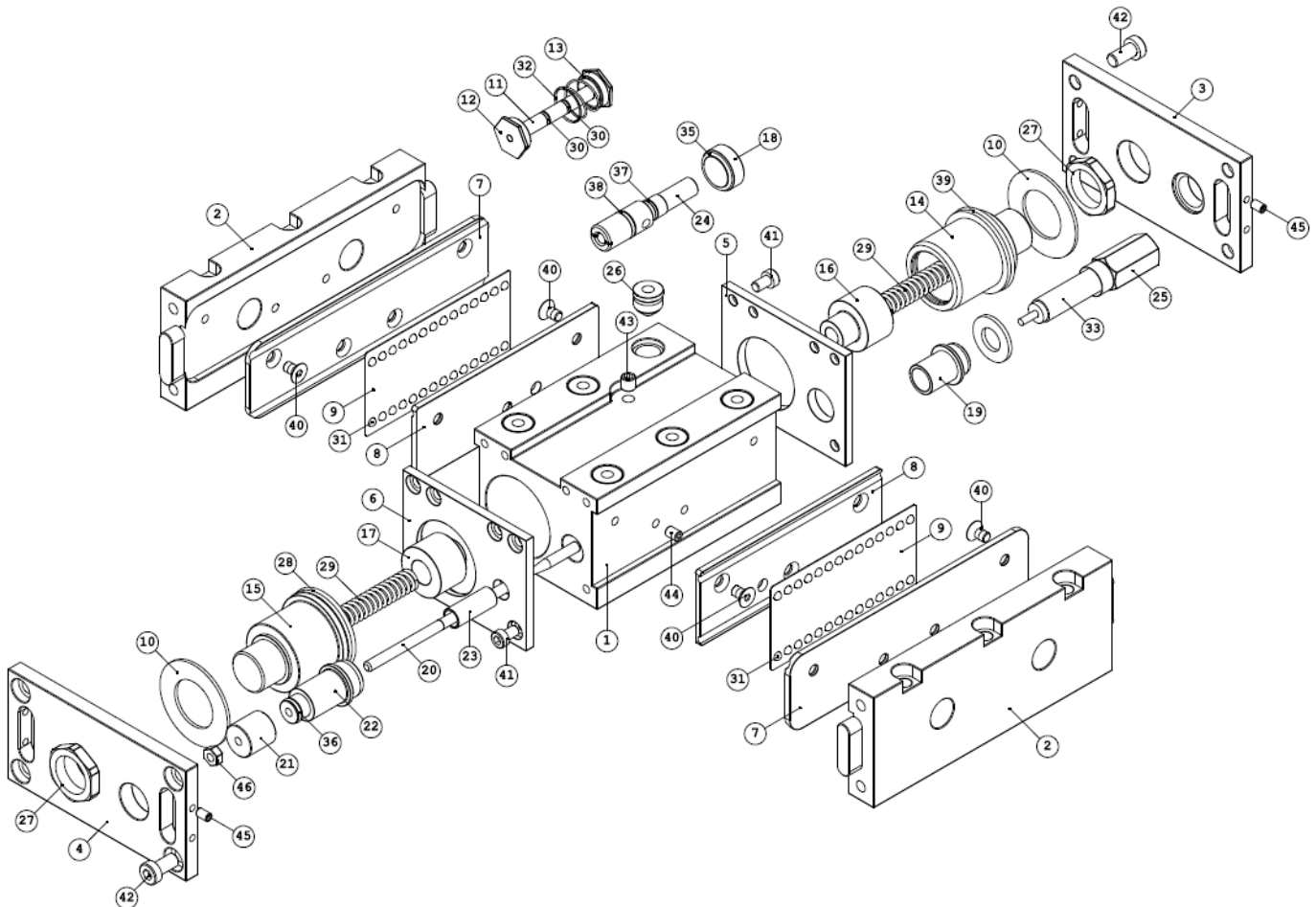

* Included in repair kit 8107.0803.0070.001



Essemec s.r.l.
Unipersonale
Via Ghebo 24 - 26 B
35017 Piombino Dese
Padova - Italy

T +39 049 5743140
F +39 049 9368154
www.newstark.it
info@newstark.it
CF / P IVA03949140283